

# Video and Image Processing Blockset

For Use with Simulink®

- Modeling
- Simulation
- Implementation

User's Guide

*Version 1*



## How to Contact The MathWorks:



www.mathworks.com      Web  
comp.soft-sys.matlab      Newsgroup



support@mathworks.com      Technical Support  
suggest@mathworks.com      Product enhancement suggestions  
bugs@mathworks.com      Bug reports  
doc@mathworks.com      Documentation error reports  
service@mathworks.com      Order status, license renewals, passcodes  
info@mathworks.com      Sales, pricing, and general information



508-647-7000      Phone



508-647-7001      Fax



The MathWorks, Inc.      Mail  
3 Apple Hill Drive  
Natick, MA 01760-2098

For contact information about worldwide offices, see the MathWorks Web site.

### *Video and Image Processing Blockset*

© COPYRIGHT 2004-2005 by The MathWorks, Inc.

The software described in this document is furnished under a license agreement. The software may be used or copied only under the terms of the license agreement. No part of this manual may be photocopied or reproduced in any form without prior written consent from The MathWorks, Inc.

**FEDERAL ACQUISITION:** This provision applies to all acquisitions of the Program and Documentation by, for, or through the federal government of the United States. By accepting delivery of the Program or Documentation, the government hereby agrees that this software or documentation qualifies as commercial computer software or commercial computer software documentation as such terms are used or defined in FAR 12.212, DFARS Part 227.72, and DFARS 252.227-7014. Accordingly, the terms and conditions of this Agreement and only those rights specified in this Agreement, shall pertain to and govern the use, modification, reproduction, release, performance, display, and disclosure of the Program and Documentation by the federal government (or other entity acquiring for or through the federal government) and shall supersede any conflicting contractual terms or conditions. If this License fails to meet the government's needs or is inconsistent in any respect with federal procurement law, the government agrees to return the Program and Documentation, unused, to The MathWorks, Inc.

MATLAB, Simulink, Stateflow, Handle Graphics, Real-Time Workshop, and xPC TargetBox are registered trademarks of The MathWorks, Inc.

Other product or brand names are trademarks or registered trademarks of their respective holders.

#### Revision History:

July 2004	First printing	New for Version 1.0 (Release 14)
October 2004	Second printing	Revised for Version 1.0.1 (Release 14SP1)
March 2005	Online only	Revised for Version 1.1 (Release 14SP2)

## Getting Started

1

<b>What Is the Video and Image Processing Blockset? . . .</b>	<b>1-2</b>
<b>Installation . . . . .</b>	<b>1-3</b>
Installing the Video and Image Processing Blockset . . . . .	1-3
Required Products . . . . .	1-4
Related Products . . . . .	1-4
<b>Product Demos . . . . .</b>	<b>1-5</b>
Demos in the Help Browser . . . . .	1-5
Demos on the Web . . . . .	1-6
Demos on MATLAB Central . . . . .	1-6
<b>Working with the Documentation . . . . .</b>	<b>1-7</b>
Viewing the Documentation . . . . .	1-7
Printing the Documentation . . . . .	1-8
Using This Guide . . . . .	1-8
<b>Key Blockset Concepts . . . . .</b>	<b>1-11</b>
Image Types . . . . .	1-11
Video in the Video and Image Processing Blockset . . . . .	1-12
Defining Intensity and Color . . . . .	1-12
Coordinate Systems . . . . .	1-13
Image Data Stored in Column-Major Format . . . . .	1-15
Sample Time . . . . .	1-16
Video Duration and Simulation Time . . . . .	1-17
Normal and Accelerator Mode . . . . .	1-18
Windows Dynamic Library Dependencies . . . . .	1-19
<b>Image Credits . . . . .</b>	<b>1-21</b>

## Importing and Exporting Video

### 2

<b>Working with AVI Files</b> .....	2-2
Importing and Viewing AVI Files .....	2-2
Exporting to AVI Files .....	2-5
<b>Working with Multimedia Files</b> .....	2-9
Importing and Viewing Multimedia Files .....	2-9
Exporting to Multimedia Files .....	2-12

## Conversions

### 3

<b>Intensity to Binary Conversion</b> .....	3-2
Converting Between Intensity and Binary Images Using Relational Operators .....	3-2
Converting Between Intensity and Binary Images Using the Autothreshold Block .....	3-7
<b>Color Space Conversion</b> .....	3-14
Converting Color Information from R'G'B' to Intensity ...	3-14
<b>Chroma Resampling</b> .....	3-19

## Geometric Transformation

### 4

<b>Interpolation Overview</b> .....	4-2
Nearest Neighbor Interpolation .....	4-2
Bilinear Interpolation .....	4-3
Bicubic Interpolation .....	4-4
<b>Rotating an Image</b> .....	4-6

<b>Resizing an Image</b> .....	<b>4-14</b>
<b>Cropping an Image</b> .....	<b>4-21</b>

## **Morphological Operations**

### **5**

<b>Overview of Morphology</b> .....	<b>5-2</b>
<b>Counting Objects in an Image</b> .....	<b>5-3</b>
<b>Correcting for Nonuniform Illumination</b> .....	<b>5-11</b>

## **Analysis and Enhancement**

### **6**

<b>Image Analysis</b> .....	<b>6-2</b>
Finding Edges in an Image .....	<b>6-2</b>
<b>Image Enhancement</b> .....	<b>6-10</b>
Sharpening and Blurring an Image .....	<b>6-10</b>
Removing Salt and Pepper Noise from Images .....	<b>6-17</b>
Removing Periodic Noise from Video .....	<b>6-23</b>
<b>Pixel Statistics</b> .....	<b>6-30</b>
Finding the Histogram of an Image .....	<b>6-30</b>

## **Example Applications**

### **7**

<b>Pattern Matching</b> .....	<b>7-2</b>
-------------------------------	------------

Tracking an Object Using Correlation .....	7-2
<b>Motion Compensation</b> .....	7-8
<b>Image Compression</b> .....	7-10
Compressing an Image .....	7-10
Viewing the Compressed Image .....	7-17

## Blocks — Categorical List

# 8

<b>Analysis &amp; Enhancement</b> .....	8-2
<b>Conversions</b> .....	8-2
<b>Filtering</b> .....	8-3
<b>Geometric Transformations</b> .....	8-3
<b>Morphological Operations</b> .....	8-4
<b>Sinks</b> .....	8-4
<b>Sources</b> .....	8-5
<b>Statistics</b> .....	8-6
<b>Text &amp; Graphics</b> .....	8-7
<b>Transforms</b> .....	8-7
<b>Utilities</b> .....	8-8

## Blocks — Alphabetical List

---

9

**Index**

---





# Getting Started

---

The Video and Image Processing Blockset is a tool for processing images and video in the Simulink® environment. This chapter provides an introduction to the Video and Image Processing Blockset, its product requirements, and its documentation.

“What Is the Video and Image Processing Blockset?” (p. 1-2)

Learn more about the Video and Image Processing Blockset and its components

“Installation” (p. 1-3)

Install the Video and Image Processing Blockset and learn about the products required to run the models in this manual

“Product Demos” (p. 1-5)

View the demos available in the product and on the Web

“Working with the Documentation” (p. 1-7)

Learn how to view and print the documentation

“Key Blockset Concepts” (p. 1-11)

Understand how your image and video data is interpreted within the Simulink environment

“Image Credits” (p. 1-21)

View a list of the copyright owners of the images used in the Video and Image Processing Blockset documentation

## **What Is the Video and Image Processing Blockset?**

The Video and Image Processing Blockset is a tool used for the rapid design, prototyping, graphical simulation, and efficient code generation of video processing algorithms. The Video and Image Processing Blockset blocks can import streaming video into the Simulink environment and perform two-dimensional filtering, geometric and frequency transforms, block processing, motion estimation, edge detection and other signal processing algorithms. You can also use the blockset in conjunction with Real-Time Workshop® to automatically generate embeddable C code for real-time execution.

The Video and Image Processing Blockset blocks support floating-point, integer, and fixed-point data types. To use any data type other than double-precision and single-precision floating point, you must install Simulink Fixed Point. For more information about this product, see the Simulink Fixed Point documentation.

# Installation

This section describes how to install the Video and Image Processing Blockset software and documentation. It also reviews the other MathWorks products you must install to run the Video and Image Processing Blockset.

This section includes the following topics:

- “Installing the Video and Image Processing Blockset” on page 1-3 – Learn how to install the Video and Image Processing Blockset and its documentation from a CD or a Web download.
- “Required Products” on page 1-4 – Links to products you must install to run the Video and Image Processing Blockset.
- “Related Products” on page 1-4 – Links to other products that are relevant to the kinds of tasks you can perform with the Video and Image Processing Blockset.

## Installing the Video and Image Processing Blockset

Before you begin working with the Video and Image Processing Blockset, you need to install the product on your computer.

### Installation from a CD

The Video and Image Processing Blockset follows the same installation procedure as the MATLAB® toolboxes:

- 1 Start the MathWorks installer.
- 2 When prompted, select the **Product** check boxes for the products you want to install.

The documentation is installed along with the products.

### Installation from a Web Download

You can use your Access Login account to download products from the MathWorks Web site:

- 1 Navigate to [http://www.mathworks.com/web\\_downloads/](http://www.mathworks.com/web_downloads/)

- 2** Click **Download products**.
- 3** Log in to the system using your Access Login account e-mail and password. If you do not have an Access Login account, you can create one from this Web page.
- 4** Select your platform and the products you want to install.
- 5** Follow the instructions on the **Download and Install** screen, which describe how to download the product(s) and the installer.
- 6** Double-click the `Installer.exe` file to run the installer.
- 7** When prompted, enter your Personal License Password.
- 8** Select the **Product** check boxes for the products you want to install.

The documentation is installed along with the products.

## Required Products

The Video and Image Processing Blockset is part of a family of products from The MathWorks. You need to install several products to use the Video and Image Processing Blockset. For more information, see the MathWorks Web site at <http://www.mathworks.com/products/viprocessing/requirements.jsp>.

## Related Products

The MathWorks provides several products that are relevant to the kinds of tasks you can perform with the Video and Image Processing Blockset.

For more information about any of these products, see either

- The online documentation for that product if it is installed on your system
- The MathWorks Web site, at <http://www.mathworks.com/products/viprocessing/related.jsp>

## Product Demos

The Video and Image Processing Blockset has a number of demo models that solve real-world problems. Begin viewing Video and Image Processing Blockset demos by using the MATLAB Help browser. For additional demo models, navigate to the MathWorks and MATLAB Central Web sites.

This section includes the following topics:

- “Demos in the Help Browser” on page 1-5 – View and interact with Video and Image Processing Blockset product demos in the Help browser
- “Demos on the Web” on page 1-6 – View Video and Image Processing Blockset Web demos on the MathWorks Web site
- “Demos on MATLAB Central” on page 1-6 – View user and developer contributed Video and Image Processing Blockset demos on the MATLAB Central Web site

### Demos in the Help Browser

You can find interactive Video and Image Processing Blockset demos in the MATLAB Help browser. This example shows you how to locate and open a typical demo:

- 1** To open the Help browser to the **Demos** tab, type `demodemos` at the MATLAB command line.
- 2** On the left side of the Help browser, double-click **Blocksets**, and then double-click **Video and Image Processing** to see a list of demo categories.
- 3** The Pattern matching demo, which demonstrates object tracking in a video stream, is a typical Video and Image Processing Blockset demo. To view the description of this demo, double-click **Detection and Tracking**, and then click **Pattern matching**.
- 4** Click **Open this model** to display the Simulink model for this demo. Run the model by selecting **Start** from the **Simulation** menu in the model window.

## **Demos on the Web**

The MathWorks Web site contains demos that show you how to use the Video and Image Processing Blockset. You can find these demos at <http://www.mathworks.com/products/viprocessing/demos.jsp>.

You can run these demos without having MATLAB or the Video and Image Processing Blockset installed on your system.

## **Demos on MATLAB Central**

MATLAB Central contains files, including demos, contributed by users and developers of the Video and Image Processing Blockset, MATLAB, Simulink and other products. Contributors submit their files to one of a list of categories. You can browse these categories to find submissions that pertain to the Video and Image Processing Blockset or a specific problem that you would like to solve. MATLAB Central is located at <http://www.mathworks.com/matlabcentral/>.

## Working with the Documentation

The Video and Image Processing Blockset documentation includes the Video and Image Processing Blockset User's Guide. You can access this documentation using the MATLAB Help browser or on the MathWorks Web site.

This section includes the following topics:

- “Viewing the Documentation” on page 1-7 – View HTML files on your system or the MathWorks Web site
- “Printing the Documentation” on page 1-8 – Locate and print PDF files on the MathWorks Web site
- “Using This Guide” on page 1-8 – Suggestions for learning about the Video and Image Processing Blockset and a description of the chapters in this manual

### Viewing the Documentation

You can access the Video and Image Processing Blockset documentation using files you installed on your system or from the Web using the MathWorks Web site.

#### Documentation in the Help Browser

This procedure shows you how to use the MATLAB Help browser to view the Video and Image Processing Blockset documentation installed on your system:

- 1** In the MATLAB window, from the **Help** menu, click **Full Product Family Help**. The Help browser opens.
- 2** From the list of products in the left pane, click **Video and Image Processing Blockset**. In the right pane, the Help browser displays the Video and Image Processing Blockset Roadmap page.
- 3** Under the section titled **Documentation Set**, select **User's Guide**. The Help browser displays the chapters of this manual.

The Help browser also has a **Demos** tab where you can view product demos. For more information, see “Product Demos” on page 1-5.

## Documentation on the Web

You can also view the documentation from the MathWorks Web site. The documentation available on these Web pages is for the latest release, regardless of whether the release was distributed on a CD or as a Web download:

- 1 Navigate to the Video and Image Processing Blockset Product Page at <http://www.mathworks.com/products/viprocessing/>.
- 2 On the right side of the page, click on the **Documentation** link. The Video and Image Processing Blockset documentation is displayed.

## Printing the Documentation

The documentation for the Video and Image Processing Blockset is also available in printable PDF format. You need to install Adobe Acrobat Reader 4.0 or later to open and read these files. To download a free copy of Acrobat Reader, see <http://www.adobe.com/products/acrobat/main.html>.

The following procedure shows you how to view the documentation in PDF format:

- 1 In the MATLAB window, from the **Help** menu, click **Full Product Family Help**. The Help browser opens.
- 2 From the list of products in the left pane, click **Video and Image Processing Blockset**. In the right pane, the Help browser displays the Video and Image Processing Blockset Roadmap page.
- 3 Under the **Printing the Documentation Set** heading, click on the links to view PDF versions of the Video and Image Processing Blockset documentation.

## Using This Guide

To help you effectively read and use this guide, here is a brief description of the chapters and a suggested reading path.

## Expected Background

This manual assumes that you are already familiar with



- MATLAB, to write scripts and functions with M-code, and to use functions with the command-line interface
- Simulink, to create simple models as block diagrams and simulate those models

## What Chapter Should I Read?

Follow the procedures in this guide to become familiar with the blockset's functionality. The User's Guide contains tutorial sections that are designed to help you become familiar with using Simulink and the Video and Image Processing Blockset:

- Read Chapter 1, "Getting Started" to learn about the installation process, the products required to run the Video and Image Processing Blockset, and to view Video and Image Processing Blockset demos.
- Read Chapter 2, "Importing and Exporting Video" to understand how video is interpreted by Simulink. You also learn how to bring video data into a model, display it on your monitor, and export it to an AVI file.
- Read Chapter 3, "Conversions" to learn how to convert an intensity image to a binary image, how to convert color information between color spaces, and how to downsample the chroma components of an image.
- Read Chapter 4, "Geometric Transformation" to understand how blocks in the Geometric Transformations library interpolate values. You also learn how to rotate, resize, and crop images.
- Read Chapter 5, "Morphological Operations" to learn about morphological operations and which blocks can be used to perform them. For example, you learn how to count objects in an image and correct for nonuniform illumination.
- Read Chapter 6, "Analysis and Enhancement" to learn how to sharpen, blur, and remove noise from images. You also learn how to find object boundaries and calculate the histogram of the R, G, and B values in an image.
- Read Chapter 7, "Example Applications" to learn how to track the motion of an object in a video stream. Also, learn more about motion compensation and image compression.

For a description of each block's operation, parameters, and characteristics, see the Block Reference in the Video and Image Processing Blockset documentation

on the Web at <http://www.mathworks.com/products/viprocessing/> or in the Help browser.

## Key Blockset Concepts

In this section, you learn how the Video and Image Processing Blockset blocks interpret input matrices and arrays. Images are real-valued ordered sets of color or intensity data. The blocks interpret input matrices as images, where each element of the matrix corresponds to a single pixel in the displayed image. Video data is a series of images over time. All blocks in the Video and Image Processing Blockset can process images or video data.

This section includes the following topics:

- “Image Types” on page 1-11 – Learn how to represent binary, intensity, and RGB images
- “Video in the Video and Image Processing Blockset” on page 1-12 – Understand the representation of video
- “Defining Intensity and Color” on page 1-12— Learn how data type determines which values correspond to black and white as well as the absence or saturation of color
- “Coordinate Systems” on page 1-13— Learn how pixel and spatial coordinate systems are defined in the Video and Image Processing Blockset
- “Image Data Stored in Column-Major Format” on page 1-15 – Learn how the blockset stores image data
- “Sample Time” on page 1-16 – Learn how a block’s sample time determines when the code behind each block is executed
- “Video Duration and Simulation Time” on page 1-17 – Learn how to control the duration of the simulation
- “Normal and Accelerator Mode” on page 1-18 – Learn how to improve the performance of larger Simulink models
- “Windows Dynamic Library Dependencies” on page 1-19 – Understand when `vip_rt.dll` is needed to run executables generated for certain targets

### Image Types

Images can be binary, intensity (grayscale), or RGB.

## Binary Images

Binary images are represented by a Boolean matrix of 0's and 1's, which correspond to black and white pixels, respectively.

For more information, see "Binary Images" in the Image Processing Toolbox documentation.

## Intensity Images

Intensity images are represented by a matrix of intensity values. While intensity images are not stored with colormaps, you can use a gray colormap to display them.

For more information, see "Intensity Images" in the Image Processing Toolbox documentation.

## RGB Images

RGB images are also known as a true-color images. With the Video and Image Processing Blockset, these images are represented by an array, where the first plane represents the red pixel intensities, the second plane represents the green pixel intensities, and the third plane represents the blue pixel intensities. Blocks that perform color operations expect three input matrices, one for each color component.

For more information, see "Truecolor Images" in the Image Processing Toolbox documentation.

## Video in the Video and Image Processing Blockset

Video data is a series of images over time. Video in binary or intensity format is a series of single images. Video in RGB format is a series of matrices grouped into sets of three, where each matrix represents an R, G, or B plane.

## Defining Intensity and Color

The values in a binary, intensity, or RGB image can be different data types. The data type of the image values determines which values correspond to black and white as well as the absence or saturation of color. The table below summarizes the interpretation of the upper and lower bound of each data

type. To view the data types of the signals at each port, from the **Format** menu, point to **Port/Signal Displays**, and select **Port Data Types**.

<b>Data Type</b>	<b>Black or Absence of Color</b>	<b>White or Saturation of Color</b>
Fixed point	Minimum data type value	Maximum data type value
Floating point	0	1

---

**Note** The Video and Image Processing Blockset considers any data type other than double-precision floating point and single-precision floating point to be fixed point.

---

For example, for an intensity image whose image values are 8-bit unsigned integers, 0 is black and 255 is white. For an intensity image whose image values are double-precision floating point, 0 is black and 1 is white. For an intensity image whose image values are 16-bit signed integers, -32768 is black and 32767 is white.

For an RGB image whose image values are 8-bit unsigned integers, 0 0 0 is black, 255 255 255 is white, 255 0 0 is red, 0 255 0 is green, and 0 0 255 is blue. For an RGB image whose image values are double-precision floating point, 0 0 0 is black, 1 1 1 is white, 1 0 0 is red, 0 1 0 is green, and 0 0 1 is blue. For an RGB image whose image values are 16-bit signed integers, -32768 -32768 -32768 is black, 32767 32767 32767 is white, 32767 -32768 -32768 is red, -32768 32767 -32768 is green, and -32768 -32768 32767 is blue.

## Coordinate Systems

You can specify locations in images using various coordinate systems. This topic discusses pixel coordinates and spatial coordinates, which are the two main coordinate systems used in the Video and Image Processing Blockset.

## Pixel Coordinates

Pixel coordinates enable you to specify locations in images. In this coordinate system, the image is treated as a grid of discrete elements, ordered from top to bottom and left to right, as shown in the following figure.

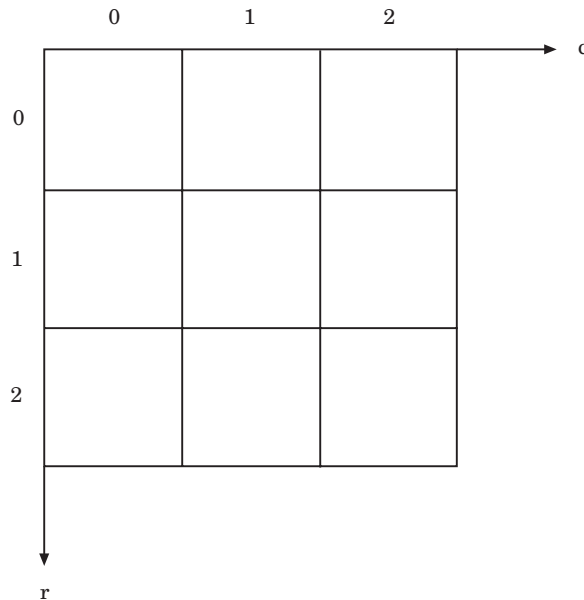

For pixel coordinates, the first component  $r$  (the row) increases downward, while the second component  $c$  (the column) increases to the right. Pixel coordinates are integer values and range between 0 and the length of the row or column. Note that the pixel coordinates used in the Video and Image Processing Blockset are zero based, while the pixel coordinates used by the Image Processing Toolbox and MATLAB are one based. For more information on the pixel coordinate system used by the Image Processing Toolbox, see Pixel Coordinates in the Image Processing Toolbox documentation.

## Spatial Coordinates

Spatial coordinates enable you to specify a location in an image with greater granularity than pixel coordinates. For example, in the pixel coordinate system, a pixel is treated as a discrete unit, uniquely identified by an integer row and column pair, such as (3,4). In a spatial coordinate system, locations

in an image can be represented in terms of partial pixels, such as (3.3, 4.7). The following figure illustrates the spatial coordinate system used for images.

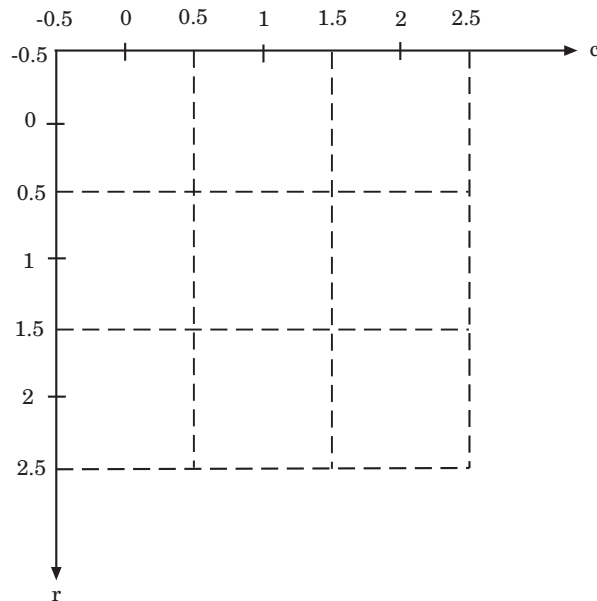

This spatial coordinate system corresponds to the pixel coordinate system in the following ways. First, both are defined in terms of row and column positions. Second, the spatial coordinates of the center point of any pixel are identical to the pixel coordinates for that pixel. However, the pixel coordinate system is discrete, while the spatial coordinate system is continuous. This means that, in pixel coordinates, the upper left corner of an image is (0,0), while in spatial coordinates, this location is (-0.5,-0.5). The spatial coordinate system used by the Video and Image Processing Blockset differs from the one used by the Image Processing Toolbox. For more information on this spatial coordinate system, see *Spatial Coordinates in the Image Processing Toolbox* documentation.

## Image Data Stored in Column-Major Format

MATLAB and the Video and Image Processing Blockset use a column-major numbering scheme to represent data elements internally. That means that

they internally store data elements from the first column first, then data elements from the second column second, and so on through the last column.

If you have imported an image or a video stream into the MATLAB workspace using a function from MATLAB or the Image Processing Toolbox, the Video and Image Processing Blockset blocks will display this image or video stream correctly. If you have written your own function or code to import images into MATLAB, you must take the column-major convention into account.

## **Sample Time**

Because the Video and Image Processing blocks calculate values directly rather than solving differential equations, you must configure the Simulink Solver to behave like a scheduler. The following steps show you how to do this:

- 1** From the model's **Simulation** menu, select **Configuration Parameters**.

The Configuration dialog box opens.

- 2** From the **Type** list, choose *Fixed-step*.

- 3** From the **Solver** list, choose *discrete (no continuous states)*.

The following figure shows the correctly configured Configuration dialog box.



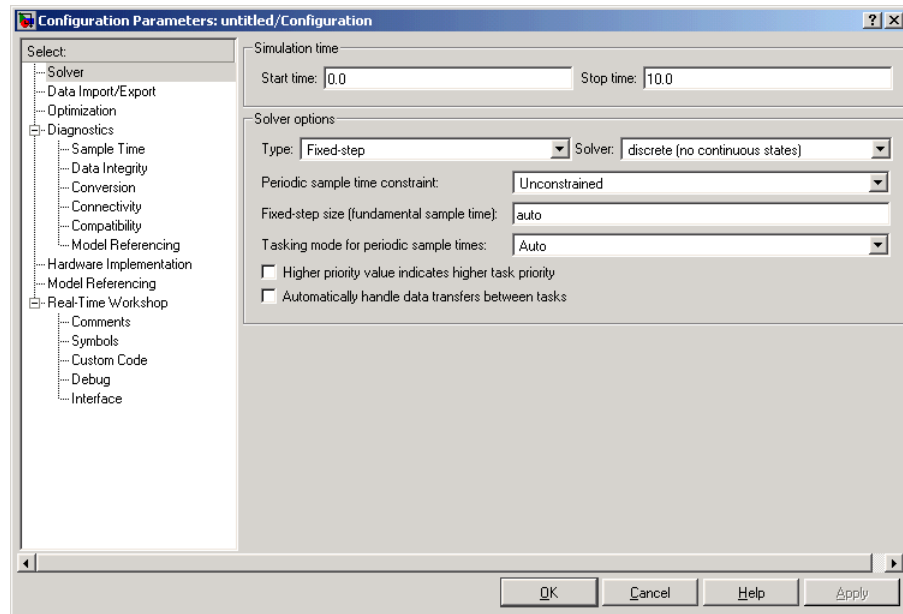

The Solver, while in scheduler mode, uses a block's sample time to determine when the code behind each block is executed. For example, if the sample time of a Video From Workspace block is 0.05, the Solver executes the code behind this block, and every other block with this sample time, once every 0.05 second.

## Video Duration and Simulation Time

The simulation does not automatically run for the duration of the input video. Use the **Stop time** parameter to control the duration of the simulation. To increase it, increase the **Stop time** parameter. To run the simulation indefinitely, enter `inf`. To view the first  $N$  frames of your video, set the **Stop time** parameter to  $(N-1)*T_s$ , where  $T_s$  is the sample time of your source block.

You can access the **Stop time** parameter in the model window, as shown in the figure below, or on the **Solver** pane of the Configuration dialog box. For more information, see "The Solver Pane" in the Simulink documentation.

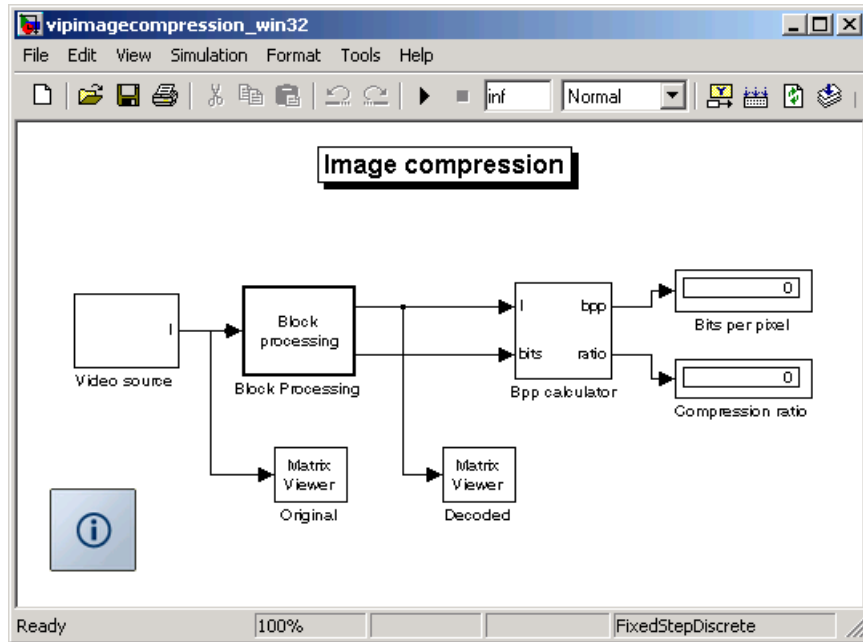

## Normal and Accelerator Mode

The Simulink Accelerator removes much of the computational overhead required by Simulink models. It works by replacing blocks that are designed to handle any possible configuration in Simulink with compiled versions customized to your particular model's configuration. Through this method, the Accelerator can achieve substantial improvements in performance for larger Simulink models. The performance gains are tied to the size and complexity of your model. Therefore, large models that contain Video and Image Processing Blockset blocks run faster in Accelerator mode. You must have the Simulink Accelerator installed on your system to take advantage of this functionality.

To change between Accelerator and Normal mode, use the drop-down list at the top of the model window.

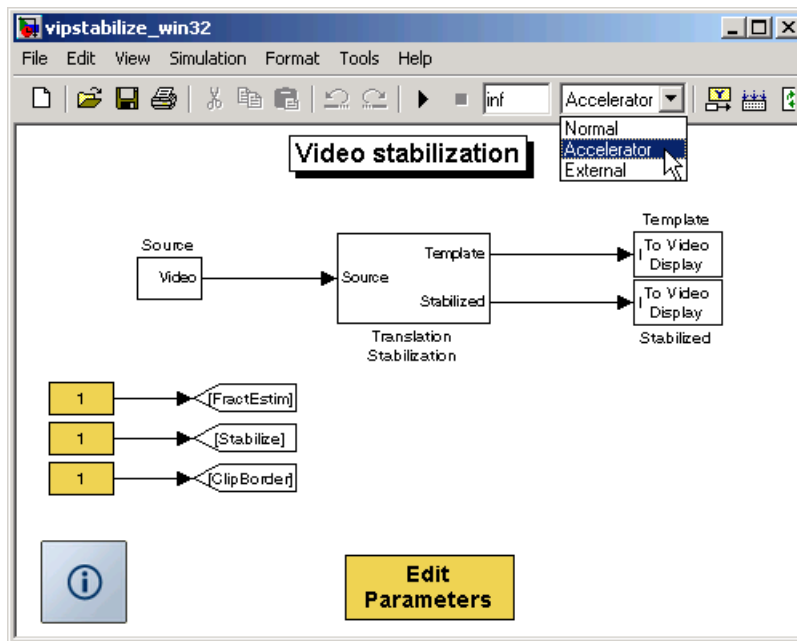

For more information, see "The Simulink Accelerator" in the Simulink documentation.

## Windows Dynamic Library Dependencies

To run executables generated for Generic Real-Time (GRT), Embedded Real-Time (ERT), and S-Function targets, you need `vip_rt.dll` if

- The Real-Time Workshop target is a Windows platform and
- You are using the default Real-Time Workshop optimization parameters

For more information about Real-Time Workshop optimization parameters, see "Generated Source Files and File Dependencies" in the Real-Time Workshop documentation.

If you want to run these executables on a Windows machine where the Video and Image Processing Blockset is not installed, copy `vip_rt.dll` from the

machine where the Video and Image Processing Blockset is installed to a directory on the system path of the other machine.

The library `vip_rt.dll` resides in `$matlabroot/bin/win32` on the machine where MATLAB and the Video and Image Processing Blockset are installed.

## Image Credits

This table lists the copyright owners of the images used in the Video and Image Processing Blockset documentation.

<b>Image</b>	<b>Source</b>
cameraman	Copyright Massachusetts Institute of Technology. Used with permission.
moon	Copyright Michael Myers. Used with permission.



# Importing and Exporting Video

---

In this chapter, you learn how to bring video data into a model, display it on your monitor, and export it to an AVI or multimedia file.

“Working with AVI Files” (p. 2-2)

Use the Read AVI File block to import video data into your Simulink model and the Write AVI File block to export video data to an AVI file.

“Working with Multimedia Files” (p. 2-9)

Use the From Multimedia File block to import video data into your Simulink model and the To Video Display block to view it. Use the To Multimedia File block to export video data to a multimedia file. These procedures assume you are working on a 32-bit Windows platform.

# Working with AVI Files

The Video and Image Processing Blockset enables you to work with video data within the Simulink environment. Before you can analyze or operate on your data, you must import it into your Simulink model. Blocks from the Sources library, such as the Read AVI File and From Multimedia File blocks, can help you with this type of task.

This section includes the following topics:

- “Importing and Viewing AVI Files” on page 2-2 – Use the Read AVI File block to import video data into your Simulink model
- “Exporting to AVI Files” on page 2-5 – Use the Write AVI File block to export video data to an AVI file

## Importing and Viewing AVI Files

In this section, you use the Read AVI File block to import an AVI file into your model and the Video Viewer block to view it:

- 1 Create a new Simulink model.
- 2 Click-and-drag the following blocks into your model.

Block	Library	Quantity
Read AVI File	Video and Image Processing Blockset / Sources	1
Video Viewer	Video and Image Processing Blockset / Sinks	1

- 3 Connect the blocks so your model looks similar to the figure below.



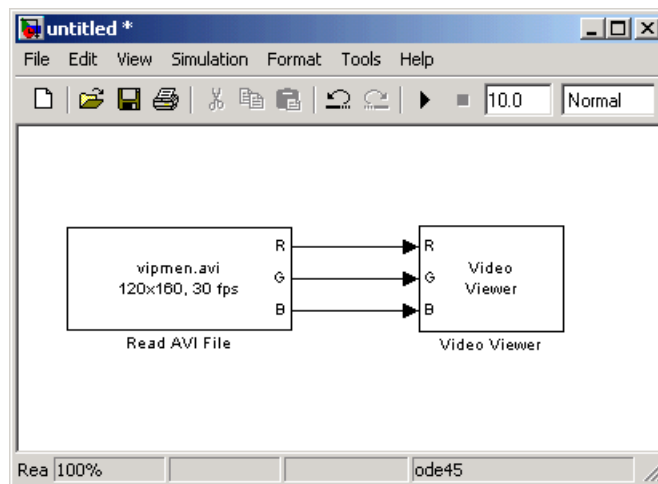

- 4 Locate an AVI file that you want to import into Simulink. If you do not have access to an AVI file, the Video and Image Processing Blockset has sample AVI files you can use to complete this procedure.
- 5 Use the Read AVI File block to import the AVI file into the model. Double-click the Read AVI File block.
  - If you do not have your own AVI file, enter `vipmen.avi` for the **File name** parameter.
  - If the AVI file is on your MATLAB path, enter the AVI filename for the **File name** parameter.
  - If the file is not on your MATLAB path, use the **Browse** button to locate the AVI filename.

By default, the **Loop** check box is selected and the **Number of times to play file** parameter is set to `inf`. The model continues to play the file until the simulation stops.

- 6 Use the Video Viewer block to view the AVI file. Use the default parameters.
- 7 Set the configuration parameters. Open the Configuration dialog box by selecting **Configuration Parameters** from the **Simulation** menu. Set the parameters as follows:

- **Solver** pane, **Stop time** = 20
- **Solver** pane, **Type** = Fixed-step
- **Solver** pane, **Solver** = discrete (no continuous states)

### 8 Run your model.

View your video in the Video Viewer window that automatically appears when you start your simulation. To view the video at its true size, right-click the window and select **Set Display To True Size**. To save the size and the position of the Video Viewer window, right-click and select **Save Position**.

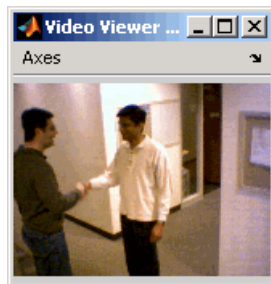

---

**Note** The video that is displayed in the Video Viewer window runs as fast as Simulink processes the video frames. If you are on a Windows platform and you want to run the video at the frame rate that corresponds to the input sample time, use the To Video Display block.

---

You have now imported and displayed video data in your Simulink model. In the next topic, “Exporting to AVI Files” on page 2-5, you manipulate your video stream and export it to an AVI file. For more information on the blocks used in this example, see the Read AVI File and Video Viewer block reference pages. To listen to audio associated with an AVI file, use the To Wave Device block in the Signal Processing Blockset.

---

**Note** The Video Viewer block is supported on all platforms, but it does not support code generation. If you are on a 32-bit Windows platform, you can use the To Video Display block to display video data. This block supports code generation. For more information, see the To Video Display block reference page.

---

## Exporting to AVI Files

The Video and Image Processing Blockset enables you to export video data from your Simulink model. In this section, you use the Write AVI File block to export an AVI file from your model:

- 1 If the model you created in “Importing and Viewing AVI Files” on page 2-2 is not open on your desktop, you can open an equivalent model by typing

```
doc_export
```

at the MATLAB command prompt.

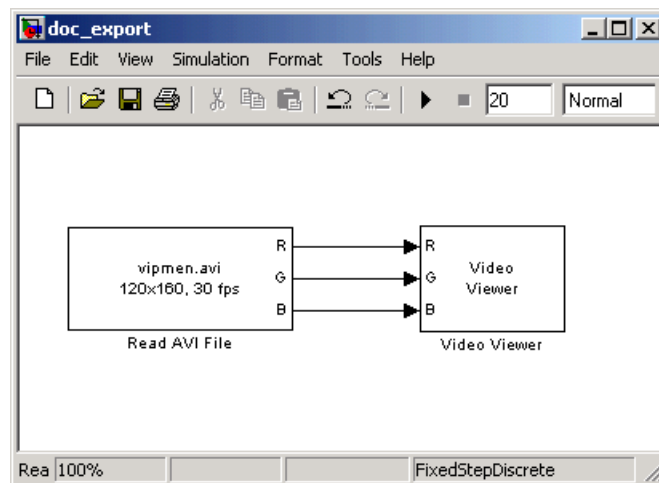

- 2 Click-and-drag the following blocks into your model.

Block	Library	Quantity
Write AVI File	Video and Image Processing Blockset / Sinks	1
Gain	Simulink / Math Operations	2

- 3 Connect the blocks as shown in the following figure. You might need to resize some blocks to do so.

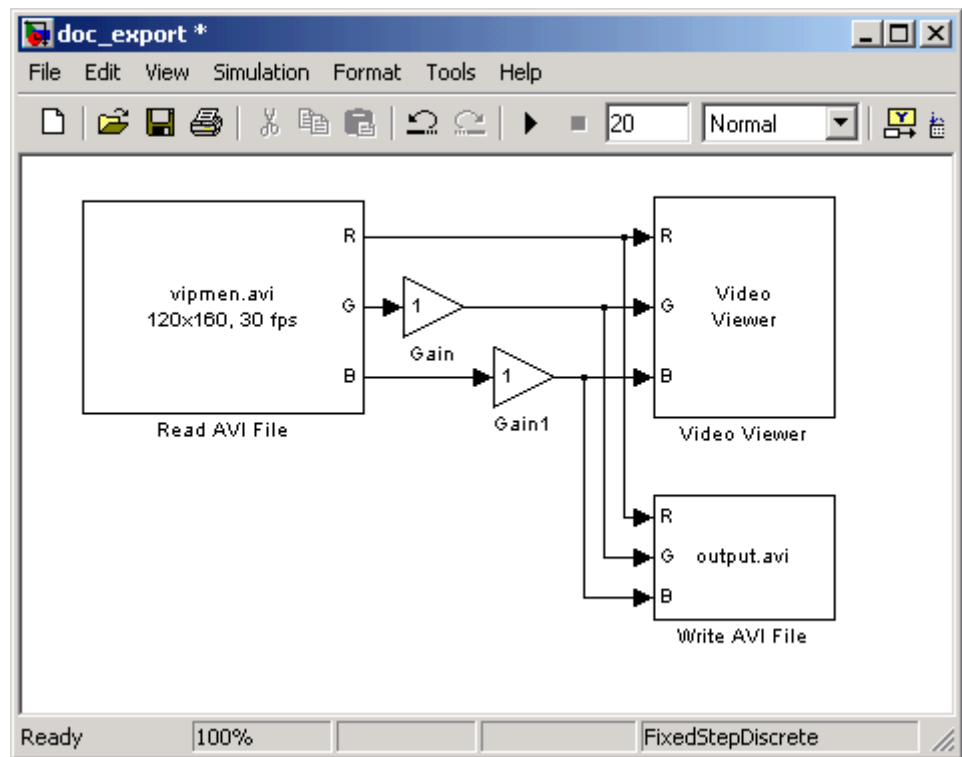

You are now ready to set your block parameters by double-clicking the blocks, modifying the block parameter values, and clicking **OK**.

- 4 Use the Gain block to change the green values of the video stream. Set the block parameters as follows:

- **Main** pane, **Gain** = 0.3
  - **Signal data types** pane, **Output data type mode** = Same as input
- 5 Use the Gain1 block to change the blue values of the video stream. Set the block parameters as follows:
- **Main** pane, **Gain** = 1.5
  - **Signal data types** pane, **Output data type mode** = Same as input
- 6 Use the Write AVI File block to export the video to an AVI file. Set the **File name** parameter to my\_test\_file.avi.

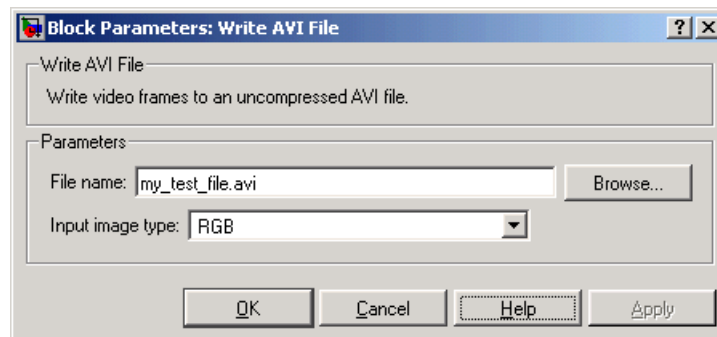

- 7 If you have not already done so, set the configuration parameters. Open the Configuration dialog box by selecting **Configuration Parameters** from the **Simulation** menu. Set the parameters as follows:
- **Solver** pane, **Stop time** = 20
  - **Solver** pane, **Type** = Fixed-step
  - **Solver** pane, **Solver** = discrete (no continuous states)
- 8 Run your model.

You can view your video in the Video Viewer window. The Write AVI File block exports the video data from the Simulink model to an AVI file that it creates in your current directory.

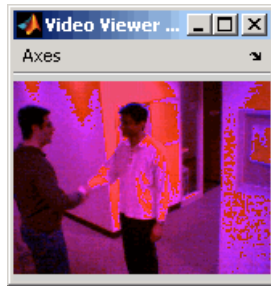

You have now manipulated your video stream and exported it from a Simulink model to an AVI file. For more information, see the [Write AVI File block reference page](#).

## Working with Multimedia Files

If you are working on a 32-bit Windows platform, the Video and Image Processing Blockset contains blocks that you can use to import and view multimedia files. These blocks include the From Multimedia File block, the To Multimedia File block, and the To Video Display block. These blocks perform best on platforms with DirectX Version 9.0 or later and Windows Media Version 9.0 or later. They also support code generation. If you generate code from a model that contains a To Video Display block, you can view the video stream when you run the executable.

This section includes the following topics:

- “Importing and Viewing Multimedia Files” on page 2-9 – Use the From Multimedia File block to import video data into your Simulink model and the To Video Display block to view it
- “Exporting to Multimedia Files” on page 2-12 – Use the To Multimedia File block to export video data to a multimedia file

### Importing and Viewing Multimedia Files

In this example, you use the From Multimedia File block to import a video stream into a Simulink model and the To Video Display block to view it. This procedure assumes you are working on a 32-bit Windows platform:

- 1 Create a new Simulink model.
- 2 Click-and-drag the following blocks into your model.

Block	Library	Quantity
From Multimedia File	Video and Image Processing Blockset / Sources	1
To Video Display	Video and Image Processing Blockset / Sinks	1

- 3 Connect the blocks so your model looks similar to the figure below.

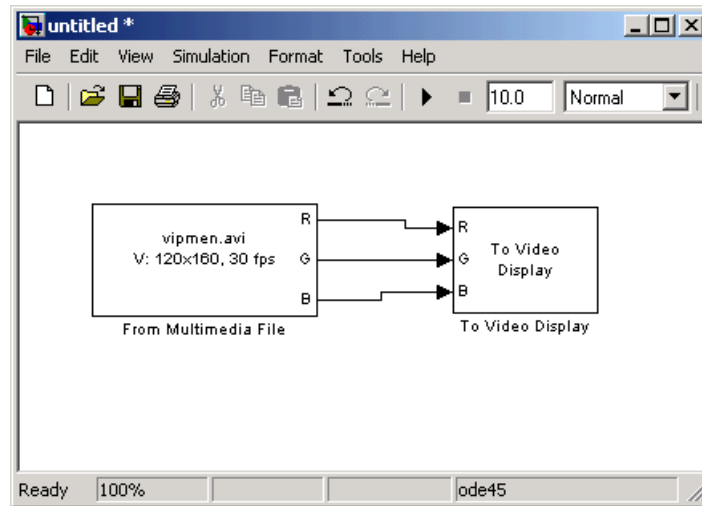

- 4 Locate a multimedia file that you want to import into Simulink. If you do not have access to a multimedia file, the Video and Image Processing Blockset has sample multimedia files you can use to complete this procedure.
- 5 Use the From Multimedia File block to import the multimedia file into the model. Double-click the From Multimedia File block:
  - If you do not have your own multimedia file, enter vipmen.avi for the **Input file name** parameter.
  - If the multimedia file is on your MATLAB path, enter the filename for the **Input file name** parameter.
  - If the file is not on your MATLAB path, use the **Browse** button to locate the multimedia file.

By default, the **Loop** check box is selected and the **Number of times to play file** parameter is set to inf. The model continues to play the file until the simulation stops.



---

**Note** The From Multimedia File block supports any multimedia file format supported by Microsoft Windows Media Player. Additionally, this block supports specialized file formats that are associated with any codec supported by Microsoft Windows Media Player.

---

- 6 Use the To Video Display block to view the multimedia file. Use the default parameters.
- 7 Set the configuration parameters. Open the Configuration dialog box by selecting **Configuration Parameters** from the **Simulation** menu. On the **Solver** pane, set the parameters as follows:
  - **Stop time** = 20
  - **Type** = Fixed-step
  - **Solver** = discrete (no continuous states)
- 8 Run your model.

View your video in the To Video Display window that automatically appears when you start your simulation. This window closes as soon as the simulation stops.



---

**Note** The video that is displayed in the To Video Display window runs at the frame rate that corresponds to the input sample time. To run the video as fast as Simulink processes the video frames, use the Video Viewer block.

---

You have now imported and displayed a multimedia file in your Simulink model. In the next topic, “Exporting to Multimedia Files” on page 2-12, you manipulate your video stream and export it to a multimedia file. For more information on the blocks used in this example, see the From Multimedia File and To Video Display block reference pages. To listen to audio associated with an AVI file, use the To Wave Device block in the Signal Processing Blockset.

### Exporting to Multimedia Files

The Video and Image Processing Blockset enables you to export video data from your Simulink model. In this section, you use the To Multimedia File block to export an multimedia file from your model. This procedure assumes you are working on a 32-bit Windows platform:

- 1 If the model you created in “Importing and Viewing Multimedia Files” on page 2-9 is not open on your desktop, you can open an equivalent model by typing

```
doc_export2
```

at the MATLAB command prompt.

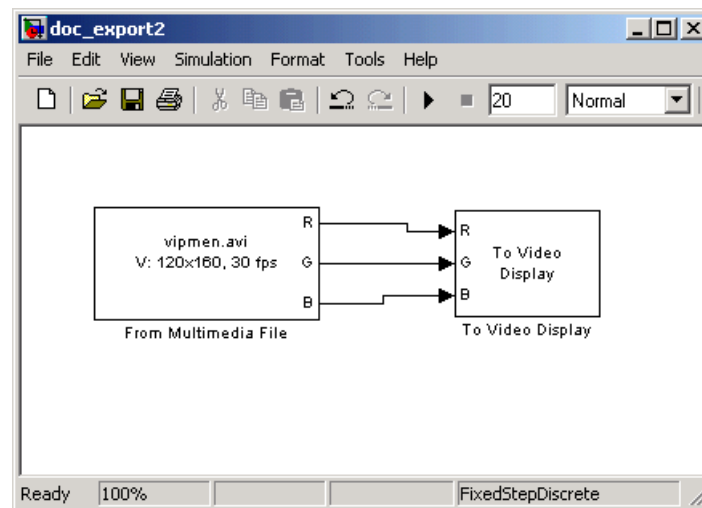

- 2 Click-and-drag the following blocks into your model.

Block	Library	Quantity
To Multimedia File	Video and Image Processing Blockset / Sinks	1
Gain	Simulink / Math Operations	3

- 3 Connect the blocks as shown in the following figure. You might need to resize some blocks to do so.

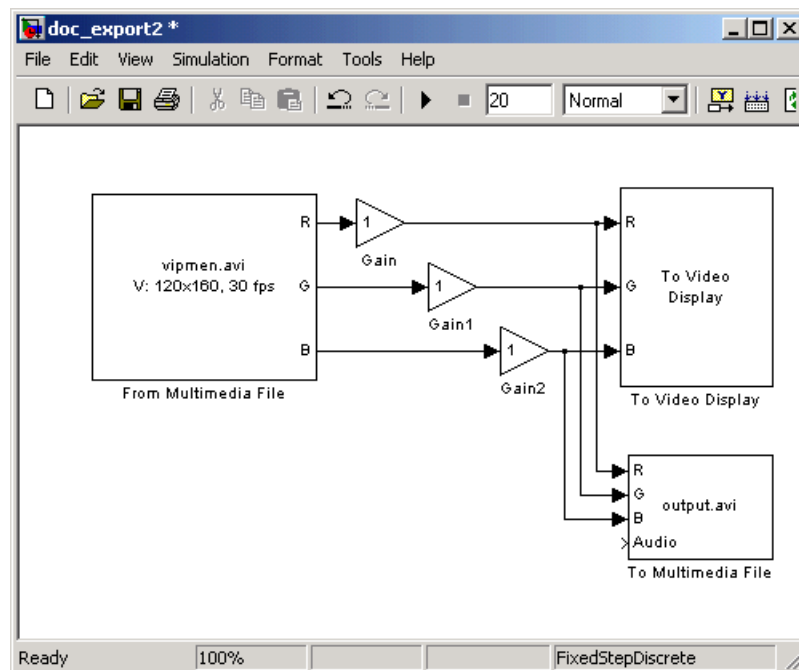

You are now ready to set your block parameters by double-clicking the blocks, modifying the block parameter values, and clicking **OK**.

- 4 Use the Gain blocks to increase the red, green, and blue values of the video stream. This increases the contrast of the video. Set the block parameters as follows:

- **Main** pane, **Gain** = 1.2
  - **Signal data types** pane, **Output data type mode** = Same as input
- 5 Use the To Multimedia File block to export the video to a multimedia file. Set the **File name** parameter to `my_output.avi`.

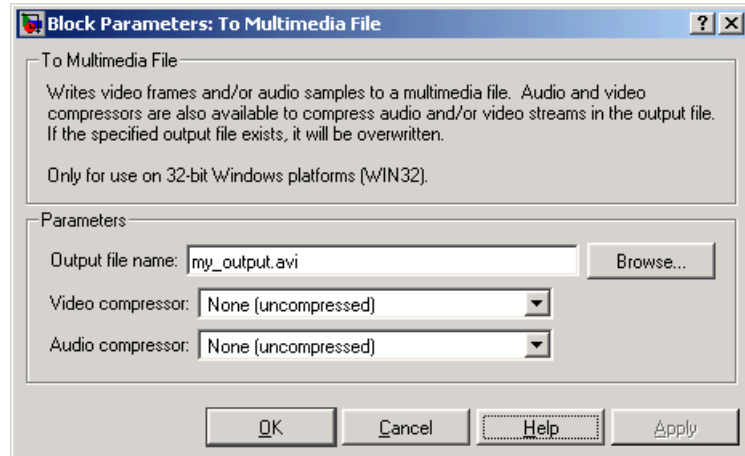

- 6 If you have not already done so, set the configuration parameters. Open the Configuration dialog box by selecting **Configuration Parameters** from the **Simulation** menu. On the **Solver** pane, set the parameters as follows:
- **Stop time** = 20
  - **Type** = Fixed-step
  - **Solver** = discrete (no continuous states)
- 7 Run your model.

You can view your video in the To Video Display window. Note that increasing the red, green, and blue color values increased the contrast of the video. The To Multimedia File block exports the video data from the Simulink model to a multimedia file that it creates in your current directory.



You have now manipulated your video stream and exported it from a Simulink model to a multimedia file. For more information, see the [To Multimedia File](#) block reference page.



# Conversions

---

In this chapter, you learn how to convert an intensity image to a binary image and an RGB image to an intensity image. You also learn how to downsample the chroma components of an image.

- |   |  |
|---|--|
| “Intensity to Binary Conversion” (p. 3-2) | Learn how to convert an intensity image to a binary image.                           |
| “Color Space Conversion” (p. 3-14)        | Learn how to convert color information between color spaces and to intensity values. |
| “Chroma Resampling” (p. 3-19)             | Use the Chroma Resampling block to downsample the chroma components of an image.     |

## Intensity to Binary Conversion

Binary images contain Boolean pixel values that are either 0 or 1. Pixels with the value 0 are displayed as black; pixels with the value 1 are displayed as white. Intensity images contain pixel values that range between the minimum and maximum values supported by their data type. Intensity images can contain only 0's and 1's, but they are not binary images unless their data type is Boolean.

This section includes the following topics:

- “Converting Between Intensity and Binary Images Using Relational Operators” on page 3-2 – Use the Relational Operator block to convert an intensity image to a binary image
- “Converting Between Intensity and Binary Images Using the Autothreshold Block” on page 3-7 – Use the Autothreshold block to convert an intensity image to a binary image

### Converting Between Intensity and Binary Images Using Relational Operators

You can use the Relational Operator block to perform a thresholding operation that converts your intensity image to a binary image. This example shows you how to accomplish this task:

- 1** Define an intensity image in the MATLAB workspace. To read in an intensity image from a PNG file, at the MATLAB command prompt, type

```
I= imread('rice.png');
```

I is a 256-by-256 matrix of 8-bit unsigned integer values that range from 0 to 255.

- 2** To view the image this matrix represents, at the MATLAB command prompt, type

```
imshow(I)
```



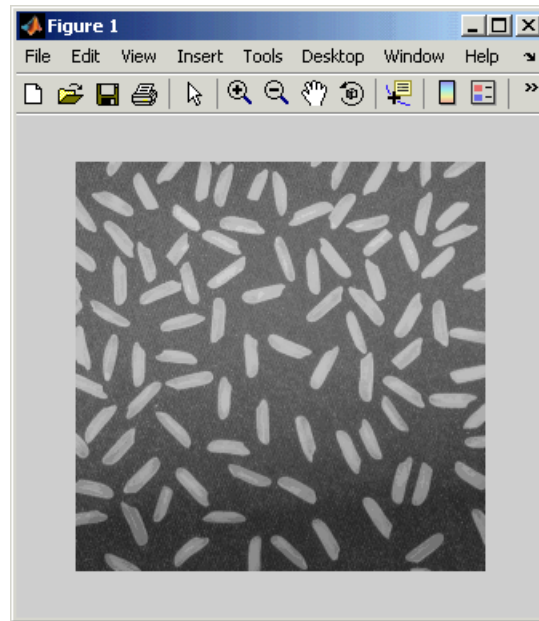

- 3 Create a new Simulink model, and add the following blocks to it.

Block	Library	Quantity
Image From Workspace	Video and Image Processing Blockset / Sources	1
Video Viewer	Video and Image Processing Blockset / Sinks	2
Relational Operator	Simulink / Logic and Bit Operations	1
Constant	Simulink / Sources	1

- 4 Position the blocks so that your model resembles the following figure.

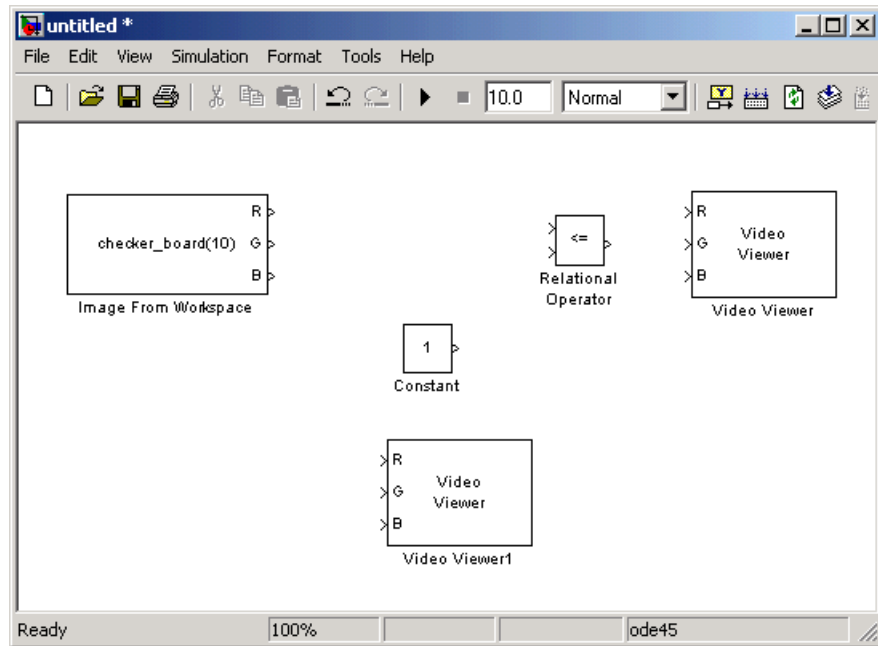

- 5 Use the Image from Workspace block to import your image from the MATLAB workspace. Set the block parameters as follows:
  - **Value** = I
  - **Output port labels** = Image
- 6 Use the Video Viewer1 block to view the original intensity image. Set the **Input image type** parameter to Intensity.
- 7 Use the Constant block to define a threshold value for the Relational Operator block. Since the pixel values range from 0 to 255, set the **Constant value** parameter to 128. Note that this value is image dependent.
- 8 Use the Relational Operator block to perform a thresholding operation that converts your intensity image to a binary image. Set the **Relational Operator** parameter to >. If the input to the Relational Operator block is greater than 128, its output is a Boolean 1; otherwise, its output is a Boolean 0.

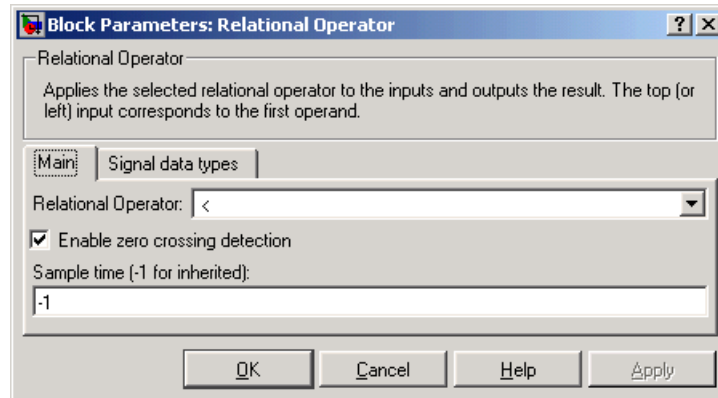

- 9 Use the Video Viewer block to view the binary image. Set the **Input image type** parameter to Intensity.
- 10 Connect the blocks as shown in the following figure.

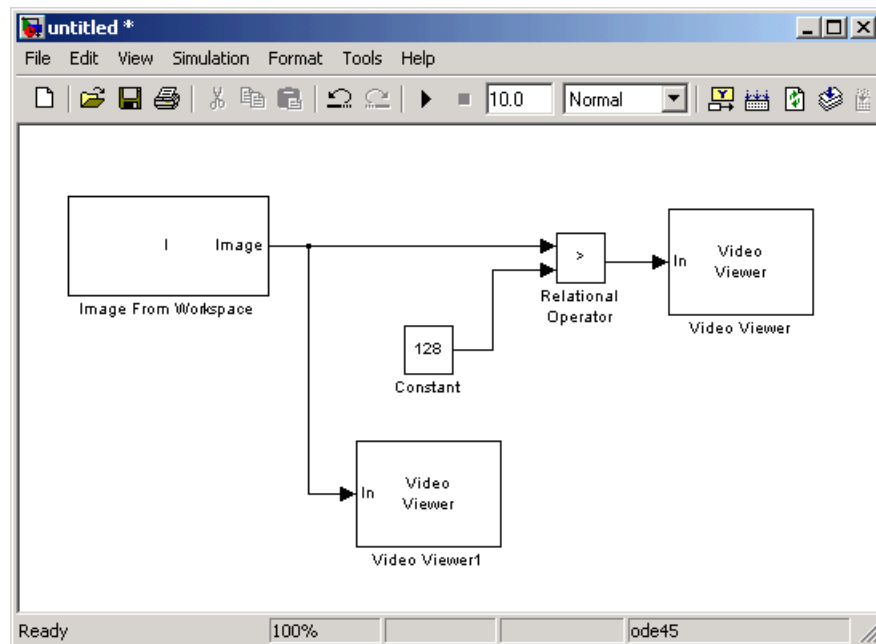

- 11 Set the configuration parameters. Open the Configuration dialog box by selecting **Configuration Parameters** from the **Simulation** menu. Set the parameters as follows:
  - **Solver** pane, **Stop time** = 0
  - **Solver** pane, **Type** = Fixed-step
  - **Solver** pane, **Solver** = discrete (no continuous states)
- 12 Run your model.

The original intensity image appears in the Video Viewer1 window.



The binary image appears in the Video Viewer window.



Note that a single threshold value was unable to effectively threshold this image due to its uneven lighting. For information on how to address this problem, see “Correcting for Nonuniform Illumination” on page 5-11.

You have used the Relational Operator block to convert an intensity image to a binary image. For more information about this block, see the Relational Operator block reference page in the Simulink documentation. For another example that uses this technique, see “Counting Objects in an Image” on page 5-3. For additional information, see "Converting Between Image Types" in the Image Processing Toolbox documentation.

## Converting Between Intensity and Binary Images Using the Autothreshold Block

In the previous topic, you used the Relational Operator block to convert an intensity image into a binary image. In this topic, you use the Autothreshold block to accomplish the same task. Use the Autothreshold block when lighting conditions vary and the threshold needs to change for each video frame:

- 1 If the model you created in “Converting Between Intensity and Binary Images Using Relational Operators” on page 3-2 is not open on your desktop, you can open an equivalent model by typing

```
doc_conversion
```

at the MATLAB command prompt.

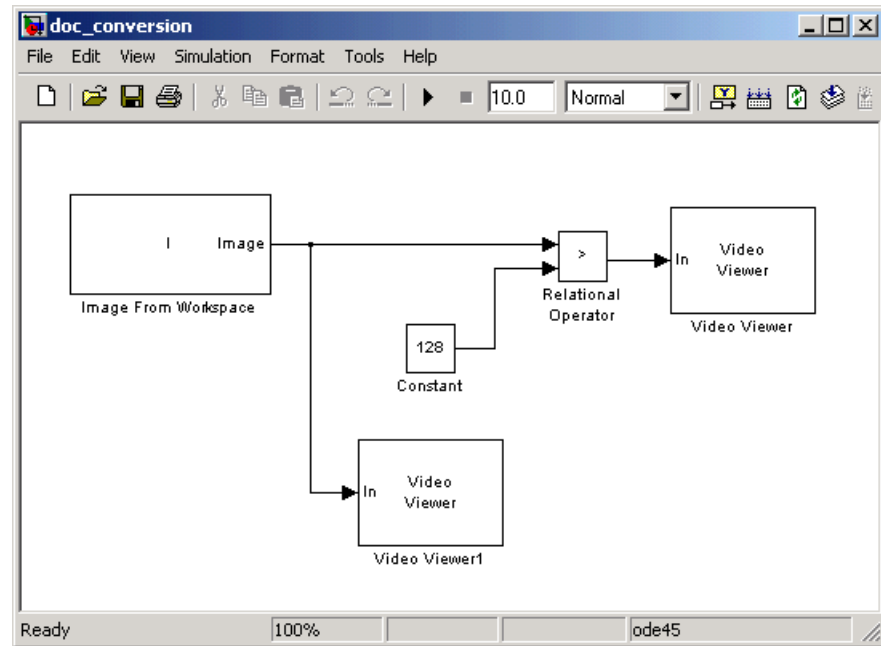

- 2 If you have not already done so, define an intensity image in the MATLAB workspace. At the MATLAB command prompt, type

```
I = imread('rice.png');
```

I is a 256-by-256 matrix of 8-bit unsigned integer values that range from 0 to 255.

- 3 Delete the Constant and the Relational Operator blocks in this model.
- 4 From the Video and Image Processing Blockset library, and then from the Conversions library, click-and-drag a Autothreshold block into your model.
- 5 Connect the blocks as shown in the figure below.

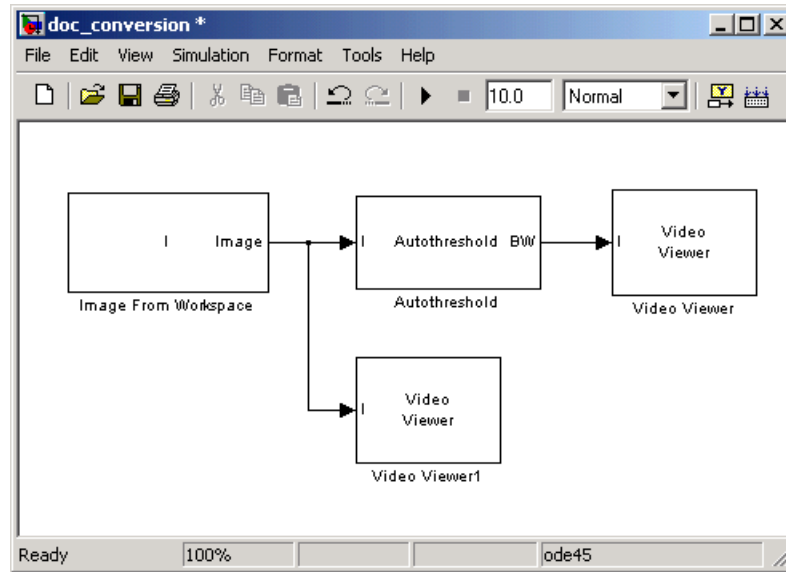

- 6 Use the Autothreshold block to perform a thresholding operation that converts your intensity image to a binary image. Select the **Output threshold** check box.

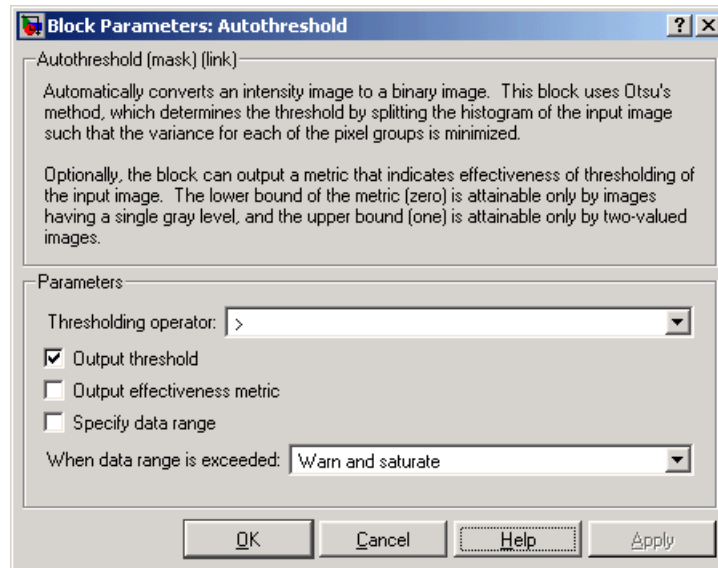

The block outputs the calculated threshold value at the Th port.

- 7 From the Signal Processing Blockset library, and then from the Signal Processing Sinks library, click-and-drag a Display block into the model. Connect it to the Th port.

Your model should look similar to the following figure:



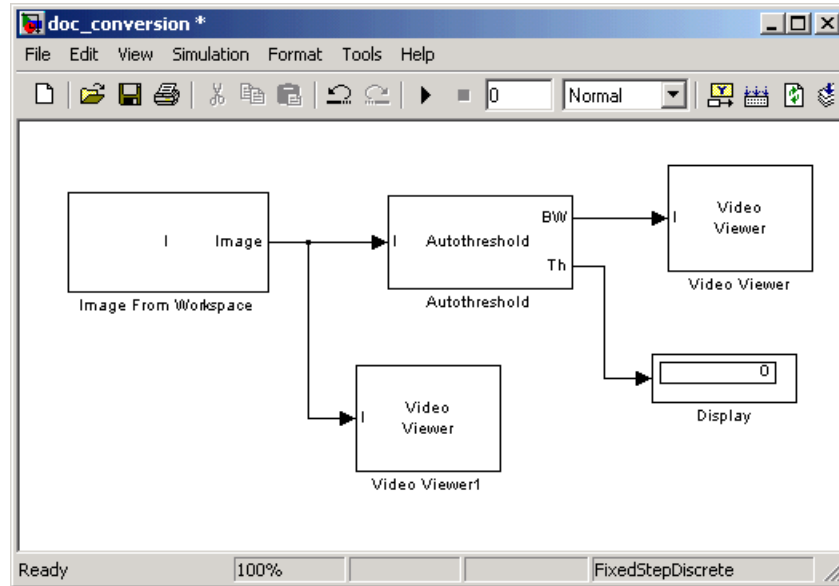

- 8 Double-click the Image From Workspace block. On the **Data Types** pane, set the **Output data type** parameter to double.
- 9 If you have not already done so, set the configuration parameters. Open the Configuration dialog box by selecting **Configuration Parameters** from the **Simulation** menu. Set the parameters as follows:
  - **Solver** pane, **Stop time** = 0
  - **Solver** pane, **Type** = Fixed-step
  - **Solver** pane, **Solver** = discrete (no continuous states)
- 10 Run the model.

The original intensity image appears in the Video Viewer1 window.



The binary image appears in the Video Viewer window.



In the model window, the Display block shows the threshold value, calculated by the Autothreshold block, that separated the rice grains from the background.

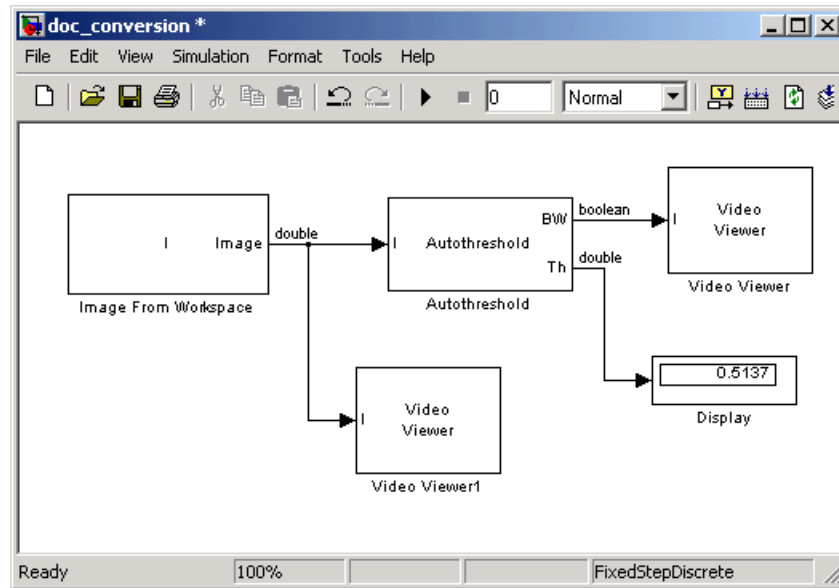

You have used the Autothreshold block to convert an intensity image to a binary image. For more information about this block, see the Autothreshold block reference page. To open a demo model that uses this block, type `vipstaples` at the MATLAB command prompt.

## Color Space Conversion

The Color Space Conversion block enables you to convert color information from the R'G'B' color space to the Y'CbCr color space and from the Y'CbCr color space to the R'G'B' color space as specified by Recommendation ITU-R BT.601-5. This block can also be used to convert from the R'G'B' color space to intensity. The prime notation indicates that the signals are gamma corrected.

This section includes the following topic:

- “Converting Color Information from R'G'B' to Intensity” on page 3-14 – Use the Color Space Conversion block to convert an R'G'B' image to intensity.

### Converting Color Information from R'G'B' to Intensity

Some image processing algorithms are customized for intensity images. If you want to use one of these algorithms, you must first convert your image to intensity. In this topic, you learn how to use the Color Space Conversion block to accomplish this task. You can use this procedure to convert any R'G'B' image to an intensity image:

- 1** Define an R'G'B' image in the MATLAB workspace. To read in an R'G'B' image from a JPG file, at the MATLAB command prompt, type

```
I = imread('greens.jpg');
```

I is a 300-by-500-by-3 array of 8-bit unsigned integer values. Each plane of this array represents the red, green, or blue color values of the image.

- 2** To view the image this matrix represents, at the MATLAB command prompt, type

```
imshow(I)
```

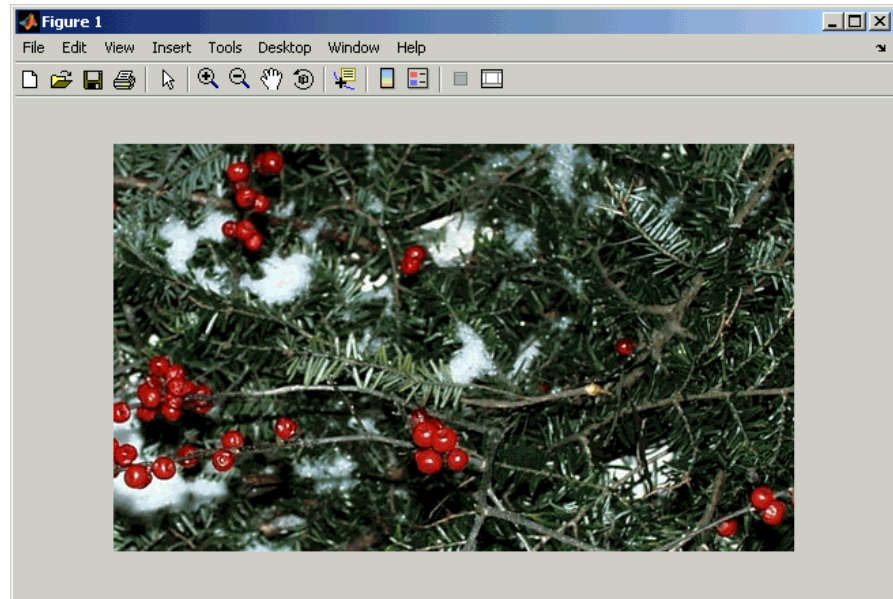

3 Create a new Simulink model, and add the following blocks to it.

Block	Library	Quantity
Image From Workspace	Video and Image Processing Blockset / Sources	1
Color Space Conversion	Video and Image Processing Blockset / Conversions	1
Video Viewer	Video and Image Processing Blockset / Sinks	1

4 Position the blocks so that your model resembles the following figure.

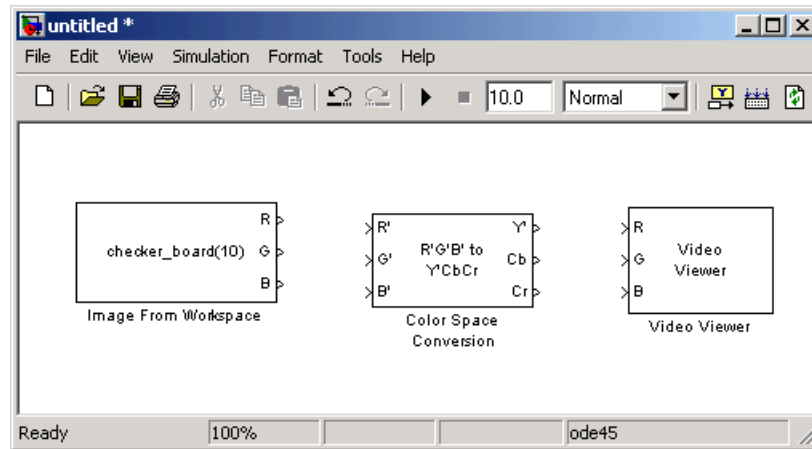

Once you have assembled the blocks needed to convert a R'G'B' image to an intensity image, you are ready to set your block parameters. To do this, double-click the blocks, modify the block parameter values, and click **OK**.

- 5 Use the Image from Workspace block to import your image from the MATLAB workspace. Set the block parameters as follows:
  - **Main pane, Value** = I
  - **Output port labels** = R' | G' | B'
- 6 Use the Color Space Conversion block to convert the input values from the R'G'B' color space to intensity. Set the **Conversion** parameter to R'G'B' to intensity.

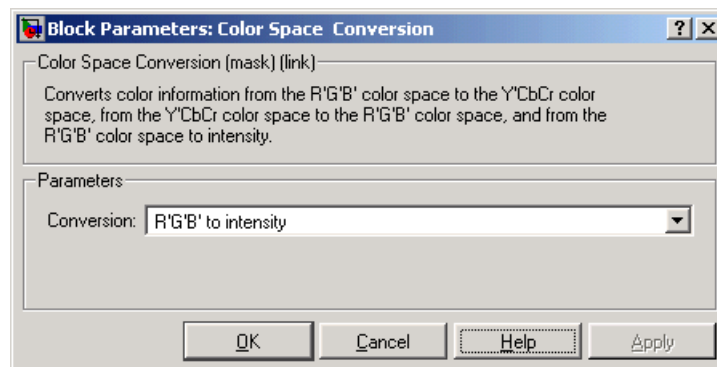

- 7 View the modified image using the Video Viewer block. Set the **Input image type** to Intensity.
- 8 Connect the blocks so that your model is similar to the following figure.

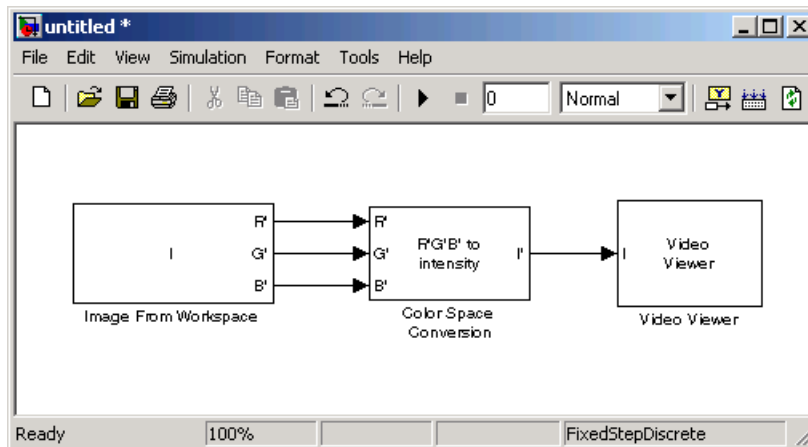

- 9 Set the configuration parameters. Open the Configuration dialog box by selecting **Configuration Parameters** from the **Simulation** menu. Set the parameters as follows:
  - **Solver** pane, **Stop time** = 0
  - **Solver** pane, **Type** = Fixed-step
  - **Solver** pane, **Solver** = discrete (no continuous states)
- 10 Run your model.

The image displayed in the Video Viewer window is the intensity version of the greens.jpg image. To view the image at its true size, right-click the window and select **Set Display To True Size**.



In this topic, you used the Color Space Conversion block to convert color information from the R'G'B' color space to intensity. For more information on this block, see the Color Space Conversion block reference page.



## Chroma Resampling

The YCbCr color space separates the luma (Y) component of an image from the chroma (Cb and Cr) components. Luma and chroma, which are calculated using gamma corrected R, G, and B (R', G', B') signals, are different quantities than the CIE chrominance and luminance. Because the human eye is more sensitive to changes in luma than to changes in chroma, you can reduce the bandwidth required for transmission or storage of a signal by removing some of the color information. For this reason, this color space is often used for digital encoding and transmission applications. In the following example, you use the Chroma Resampling block to downsample the Cb and Cr components of an image:

- 1 Define an RGB image in the MATLAB workspace. To read in an RGB image from a TIF file, at the MATLAB command prompt, type

```
I= imread('autumn.tif');
```

I is a 206-by-345-by-3 array of 8-bit unsigned integer values. Each plane of this array represents the red, green, or blue color values of the image.

- 2 To view the image this array represents, at the MATLAB command prompt, type

```
imshow(I)
```

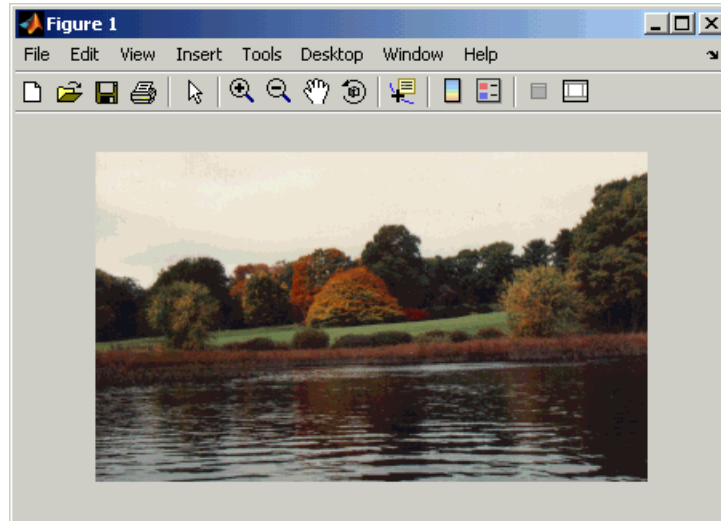

**3** Create a new Simulink model, and add the following blocks to it.

Block	Library	Quantity
Image From Workspace	Video and Image Processing Blockset / Sources	1
2-D Pad	Video and Image Processing Blockset / Utilities	1
Color Space Conversion	Video and Image Processing Blockset / Conversions	2
Chroma Resampling	Video and Image Processing Blockset / Conversions	2
Video Viewer	Video and Image Processing Blockset / Sinks	1
Bus Creator	Simulink / Signal Routing	1
Bus Selector	Simulink / Signal Routing	1

**4** Position the blocks so that your model resembles the following figure.

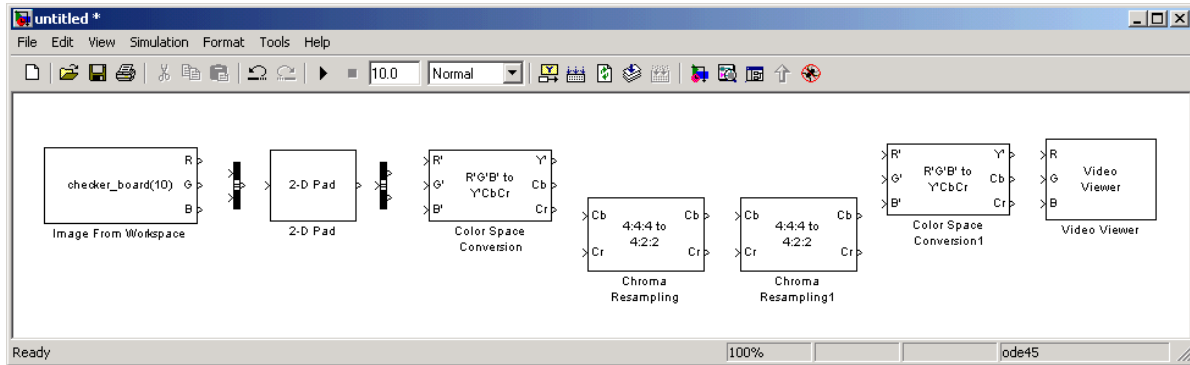

The blocks to the left of and including the Chroma Resampling block represent the transmission portion of the model. The remaining blocks represent the receiving portion of the model. Once you have assembled these blocks, you are ready to set your block parameters. To do this, double-click the blocks, modify the block parameter values, and click **OK**.

- 5 Use the Image from Workspace block to import your image from the MATLAB workspace. Set the **Value** parameter to I.
- 6 Use the Bus Creator block to combine the R, G, and B, signals into one signal so you can process it with one 2-D Pad block. Set the **Number of inputs** parameter to 3.
- 7 Use the 2-D Pad block to change the dimensions of the I array from 206-by-345-by-3 to 206-by-346-by-3. You are changing these dimensions because the Chroma Resampling block requires that the dimensions of the input be divisible by 2. Set the block parameters as follows:
  - **Method** = Symmetric
  - **Pad rows at** = Right
  - **Pad size along rows** = 1
  - **Pad columns at** = No padding

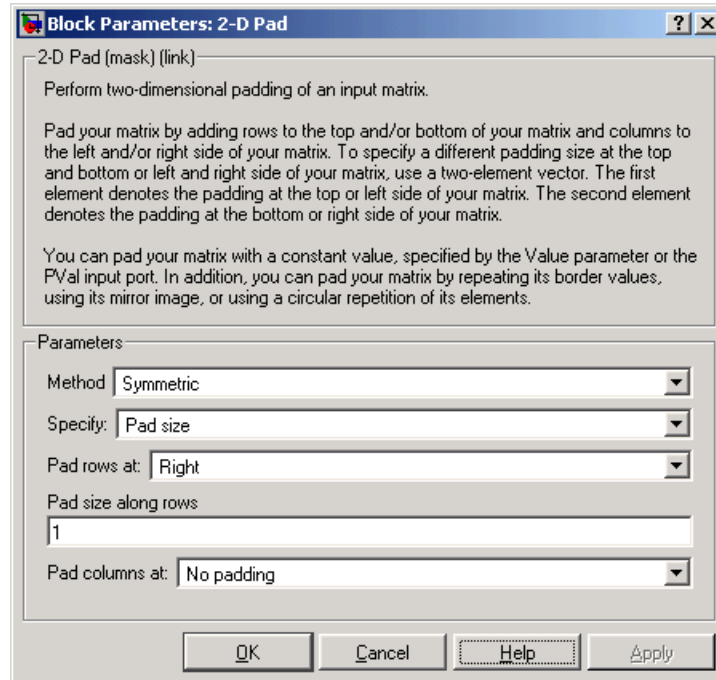

The 2-D Pad block adds one column to the right of each plane of the array by repeating its border values. This padding minimizes the effect of the pixels outside the image on the processing of the image.

---

**Note** When processing video streams, it is computationally expensive to pad every video frame. We recommend changing the dimensions of the video stream before you process it with Video and Image Processing Blockset blocks.

---

- 8 Use the Bus Selector block to expand the input signal into three separate R, G, and B, signals. You must set the block parameters of this block after you connect a signal to its input port. You configure this block later in this procedure.

- 9 Use the Color Space Conversion block to convert the input values from the R'G'B' color space to the Y'CbCr color space. The prime symbol indicates a gamma corrected signal. Use the default parameters.
- 10 Use the Chroma Resampling block to downsample the chroma components of the image from the 4:4:4 format to the 4:2:2 format. Use the default parameters.

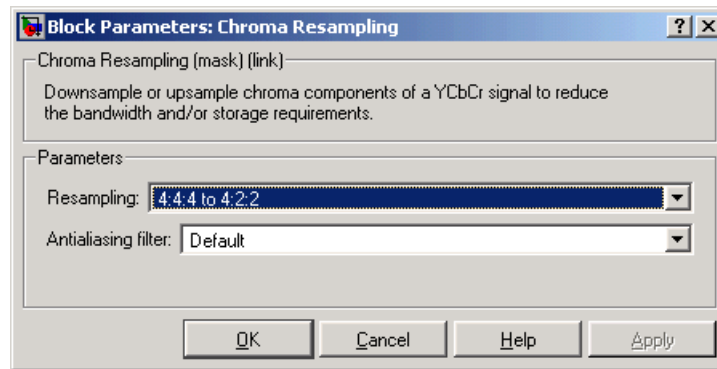

The dimensions of the output of the Chroma Resampling block are smaller than the dimensions of the input. Therefore, the output signal requires less bandwidth for transmission.

- 11 Use the Chroma Resampling1 block to upsample the chroma components of the image from the 4:2:2 format to the 4:4:4 format. Set the **Resampling** parameter to 4:2:2 to 4:4:4.
- 12 Use the Color Space Conversion1 block to convert the input values from the Y'CbCr color space to the R'G'B' color space. Set the **Conversion** parameter to Y'CbCr to R'G'B'.
- 13 Use the Video Viewer block to display the recovered image. Use the default parameters.
- 14 Connect the blocks as shown in the following figure.

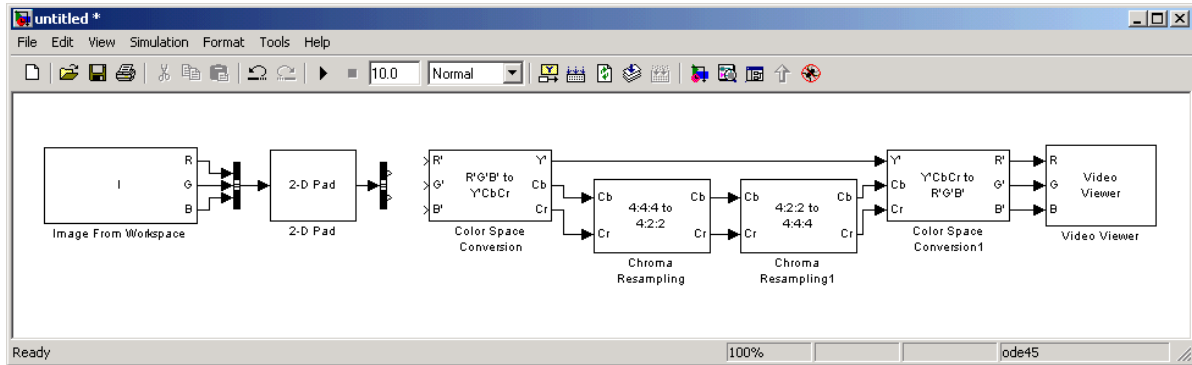

Note that the Bus Selector block, which is to the right of the 2-D Pad block, still needs to be connected to the Color Space Conversion block. You cannot configure the parameters of this block until you connect an input signal to it.

- 15 Configure the Bus Selector block. Double-click the block. In the **Signals in the bus** pane, select signal3. Click **Select** to move signal3 to the **Selected signals** pane. Click **OK**.

The Bus Selector block now has three output ports.

- 16 Connect the Bus Selector block to the Color Space Conversion block.
- 17 Configure Simulink to display signal dimensions next to each signal line. From the **Format** menu, point to **Port/Signal Displays**, and select **Signal Dimensions**.
- 18 Set the configuration parameters. Open the Configuration dialog box by selecting **Configuration Parameters** from the **Simulation** menu. Set the parameters as follows:
  - **Solver** pane, **Stop time** = 0
  - **Solver** pane, **Type** = Fixed-step
  - **Solver** pane, **Solver** = discrete (no continuous states)
- 19 Run the model.

The recovered image appears in the Video Viewer window. To view the image at its true size, right-click the window and select **Set Display To True Size**.



**20** Examine the signal dimensions in your model. The Chroma Resampling block downsamples the Cb and Cr components of the image from 206-by-346 matrices to 206-by-173 matrices. These matrices require less bandwidth for transmission while still communicating the information necessary to recover the image after it is transmitted.

You have used the Chroma Resampling block to downsample the Cb and Cr components of an image. For more information about this block, see the Chroma Resampling block reference page.





# Geometric Transformation

---

The Geometric Transformations library contains blocks that enable you to rotate, translate, shear, and resize images.

- |                                   |   |
|-----------------------------------|---|
| “Interpolation Overview” (p. 4-2) | Understand how blocks in the Geometric Transformations library interpolate values |
| “Rotating an Image” (p. 4-6)      | Use the Rotate block to continuously rotate an image                              |
| “Resizing an Image” (p. 4-14)     | Use the Resize block to reduce the size of an image                               |
| “Cropping an Image” (p. 4-21)     | Use the Selector block to trim an image down to a region of interest              |

# Interpolation Overview

The Video and Image Processing Blockset contains blocks that perform geometric transformations. These blocks use interpolation to calculate the appropriate pixel values so that images appear rotated, translated, resized, or sheared.

---

**Note** The examples in this section are illustrations of interpolation methods. The block algorithms are implemented in a slightly different way so that they are optimized for speed and memory.

---

The following sections illustrate the geometric transformation blocks' interpolation methods:

- “Nearest Neighbor Interpolation” on page 4-2 – Understand the basic concepts of nearest neighbor interpolation
- “Bilinear Interpolation” on page 4-3 – Understand the basic concepts of bilinear interpolation
- “Bicubic Interpolation” on page 4-4 – Understand the basic concepts of bicubic interpolation

## Nearest Neighbor Interpolation

For nearest neighbor interpolation, the block uses the value of nearby translated pixel values for the output pixel values.

For example, suppose this matrix,

```
1 2 3
4 5 6
7 8 9
```

represents your input image. You want to translate this image 1.7 pixels in the positive horizontal direction using nearest neighbor interpolation. The Translate block's nearest neighbor interpolation algorithm is illustrated by the following steps:

- 1 Zero pad the input matrix and translate it by 1.7 pixels to the right.

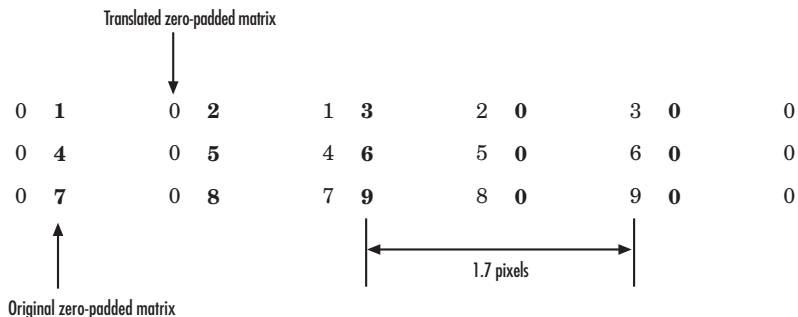

- 2 Create the output matrix by replacing each input pixel value with the translated value nearest to it. The result is the following matrix.

```

0 0 0 1 2 3
0 0 0 4 5 6
0 0 0 7 8 9

```

Note that you wanted to translate the image by 1.7 pixels, but this method translated the image by 2 pixels. Nearest neighbor interpolation is computationally efficient but not as accurate as bilinear or bicubic interpolation.

For more information, see "Interpolation" in the Image Processing Toolbox documentation.

## Bilinear Interpolation

For bilinear interpolation, the block uses the weighted average of two translated pixel values for each output pixel value.

For example, suppose this matrix,

```

1 2 3
4 5 6
7 8 9

```

represents your input image. You want to translate this image 0.5 pixel in the positive horizontal direction using bilinear interpolation. The Translate block's bilinear interpolation algorithm is illustrated by the following steps:

- 1 Zero pad the input matrix and translate it by 0.5 pixel to the right.

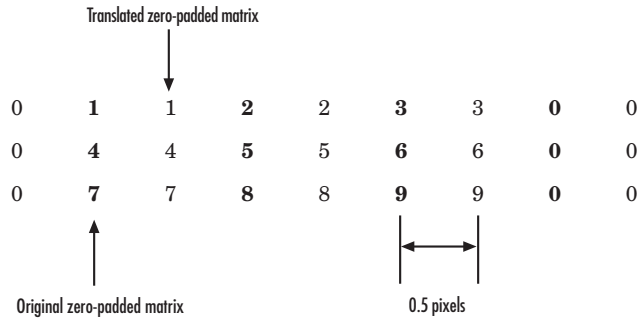

- 2 Create the output matrix by replacing each input pixel value with the weighted average of the translated values on either side. The result is the following matrix.

0.5	1.5	2.5	1.5
2	4.5	5.5	3
3.5	7.5	8.5	4.5

Note that the output matrix has one more column than the input matrix.

For more information, see "Interpolation" in the Image Processing Toolbox documentation.

### Bicubic Interpolation

For bicubic interpolation, the block uses the weighted average of four translated pixel values for each output pixel value.

For example, suppose this matrix,

```

1 2 3
4 5 6
7 8 9

```

represents your input image. You want to translate this image 0.5 pixel in the positive horizontal direction using bicubic interpolation. The Translate block's bicubic interpolation algorithm is illustrated by the following steps:

- 1 Zero pad the input matrix and translate it by 0.5 pixel to the right.

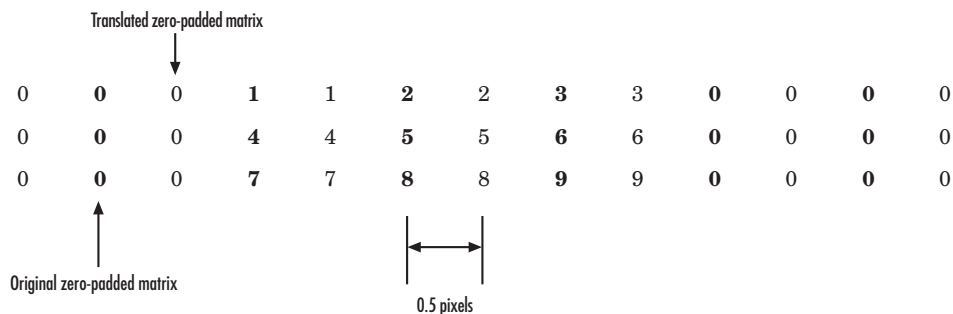

- 2 Create the output matrix by replacing each input pixel value with the weighted average of the two translated values on either side. The result is the following matrix.

```

0.375  1.5    3    1.625
1.875  4.875  6.375  3.125
3.375  8.25   9.75  4.625

```

Note that the output matrix has one more column than the input matrix.

For more information, see "Interpolation" in the Image Processing Toolbox documentation.

## Rotating an Image

You can use the Rotate block to rotate your image or video stream by a specified angle. In this example, you learn how to use the Rotate block to continuously rotate an image:

- 1 Define an RGB image in the MATLAB workspace. At the MATLAB command prompt, type

```
A = checker_board;
```

A is a 100-by-100-by-3 array of double-precision values. Each plane of the array represents the red, green, or blue color values of the image.

- 2 To view the image this matrix represents, at the MATLAB command prompt, type

```
imshow(A)
```

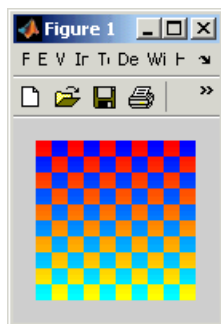

- 3 Create a new Simulink model, and add the following blocks to it.

Block	Library	Quantity
Image From Workspace	Video and Image Processing Blockset / Sources	1
Rotate	Video and Image Processing Blockset / Geometric Transformations	1

<b>Block</b>	<b>Library</b>	<b>Quantity</b>
Video Viewer	Video and Image Processing Blockset / Sinks	2
Bus Creator	Simulink / Signal Routing	1
Bus Selector	Simulink / Signal Routing	1
Gain	Simulink / Math Operations	1
Display	Signal Processing Blockset / Signal Processing Sinks	1
Counter	Signal Processing Blockset / Signal Management / Switches and Counters	1

**4** Place the blocks as shown in the figure below.

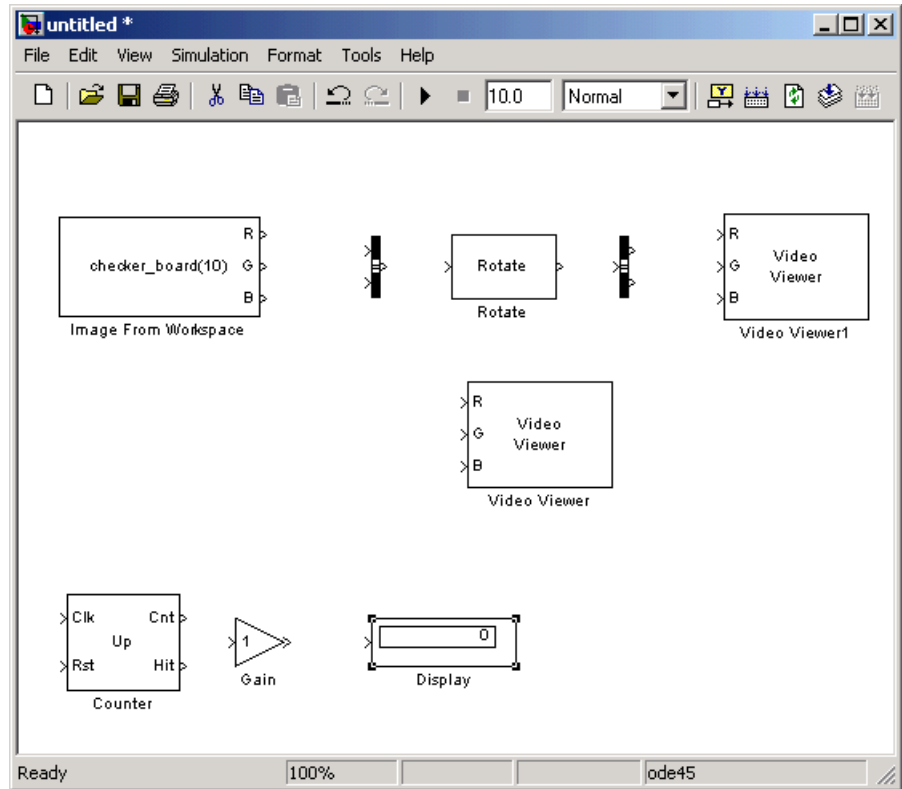

You are now ready to set your block parameters by double-clicking the blocks, modifying the block parameter values, and clicking **OK**.

- 5 Use the Image From Workspace block to import the RGB image from the MATLAB workspace. On the **Main** pane, set the **Value** parameter to A.

The block outputs the R, G, and B planes of the A array at the output ports.

- 6 Use the Video Viewer block to display the original image. Use the default parameters.

The Video Viewer block automatically displays the original image in the Video Viewer window when you run the model. Because the image is represented by double-precision floating point values, a value of 0 corresponds to black and a value of 1 corresponds to white.



- 7 Use the Bus Creator block to combine the R, G, and B planes of the A array into a single signal. This enables you to use one Rotate block to rotate the image. Set the **Number of inputs** parameter to 3.
- 8 Use the Rotate block to rotate the image. Set the **Rotation angle source** parameter to Input port.

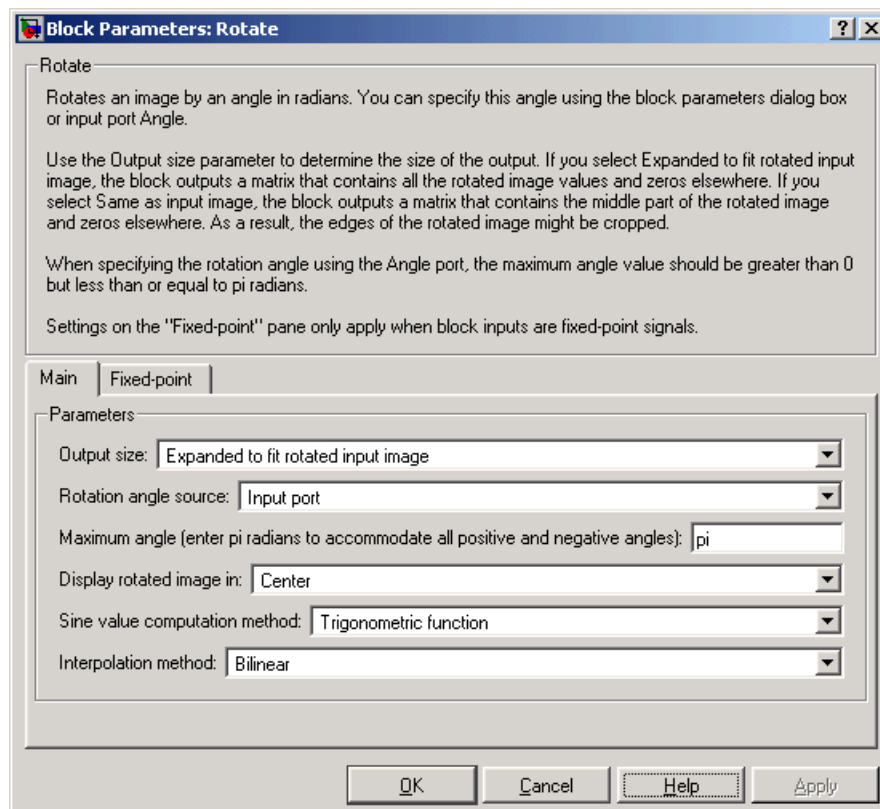

The Angle port appears on the block. You will use this port to input a steadily increasing angle. Setting the **Output size** parameter to Expanded to fit rotated input image ensures that the block does not crop the output.

- 9 Use the Bus Selector block to split the R, G, and B planes of the A array into separate signals. You must set the block parameters of this block after

you connect a signal to its input port. You configure this block later in this procedure.

- 10** Use the Video Viewer1 block to display the rotating image. Use the default parameters.
- 11** Use the Counter block to create a steadily increasing angle. Set the block parameters as follows:
  - **Count event** = Free running
  - **Counter size** = 16 bits
  - **Output** = Count
  - Clear the **Reset input** check box.
  - **Sample time** = 1/30

The Counter block counts upward until it reaches the maximum value that can be represented by 16 bits. Then, it starts again at zero. You can view its output value on the Display block while the simulation is running. You are using the Counter block from the Signal Processing Blockset because its **Count data type** parameter enables you to specify the data type of its output.

- 12** Use the Gain block to convert the output of the Counter block from degrees to radians. Set the **Gain** parameter to  $\pi/180$ .
- 13** Connect the block as shown in the following figure.

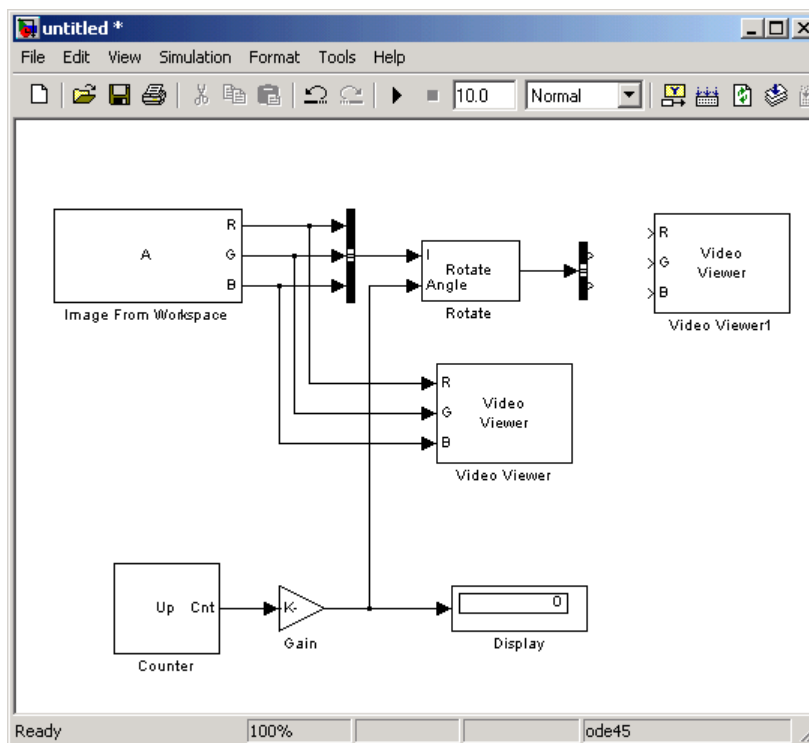

- 14** Double-click the Bus Selector block. In the **Signals in the bus** pane, select signal3, and click **Select**. Now, signal3 appears in the **Selected signals** pane. Click **OK**. Then, connect the Bus Selector block to the Video Viewer1 block.

Your model should look similar to the figure below.

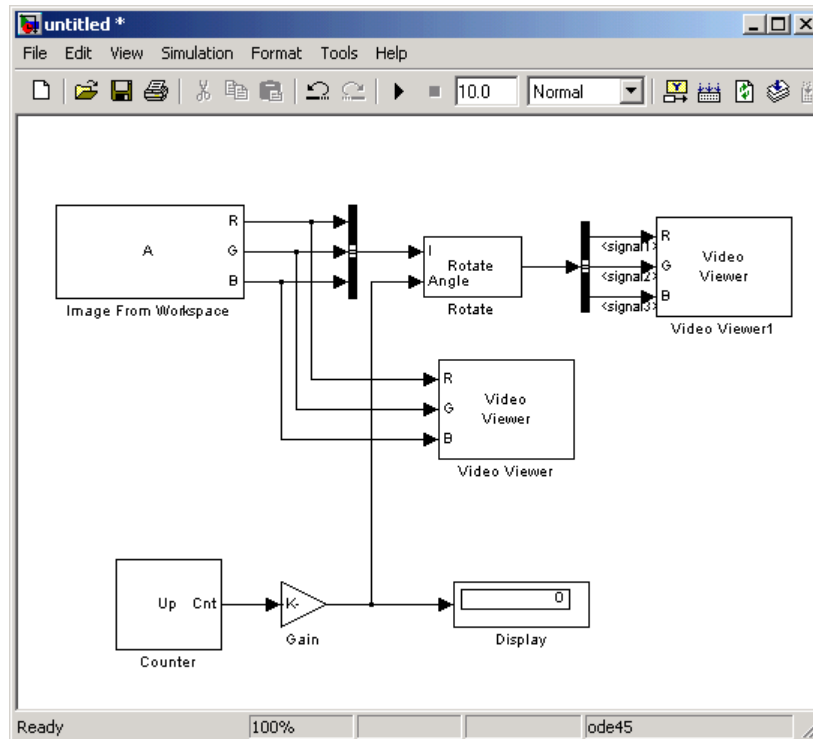

**15** Set the configuration parameters. Open the Configuration dialog box by selecting **Configuration Parameters** from the **Simulation** menu. Set the parameters as follows:

- **Solver** pane, **Stop time** = inf
- **Solver** pane, **Type** = Fixed-step
- **Solver** pane, **Solver** = discrete (no continuous states)

**16** Run the model.

The original image appears in the Video Viewer window.

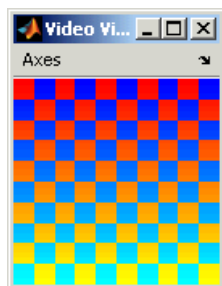

The rotating image appears in the Video Viewer1 window.

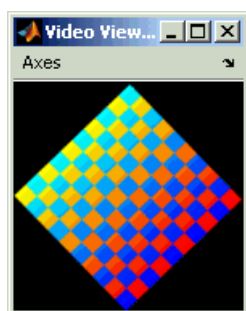

In this example, you used the Rotate block to continuously rotate your image. For more information about this block, see the Rotate block reference page. For more information about other geometric transformation blocks, see the Resize and Shear block reference pages.

---

**Note** If you are on a 32-bit Windows operating system, you can replace the Video Viewer block with the To Video Display block, which supports code generation.

---

### Resizing an Image

You can use the Resize block to change the size of your image or video stream. In this example, you learn how to use the Resize block to reduce the size of an image:

- 1 Define an intensity image in the MATLAB workspace. At the MATLAB command prompt, type

```
I = imread('moon.tif');
```

I is a 537-by-358 matrix of 8-bit unsigned integer values.

- 2 To view the image this matrix represents, at the MATLAB command prompt, type

```
imshow(I)
```

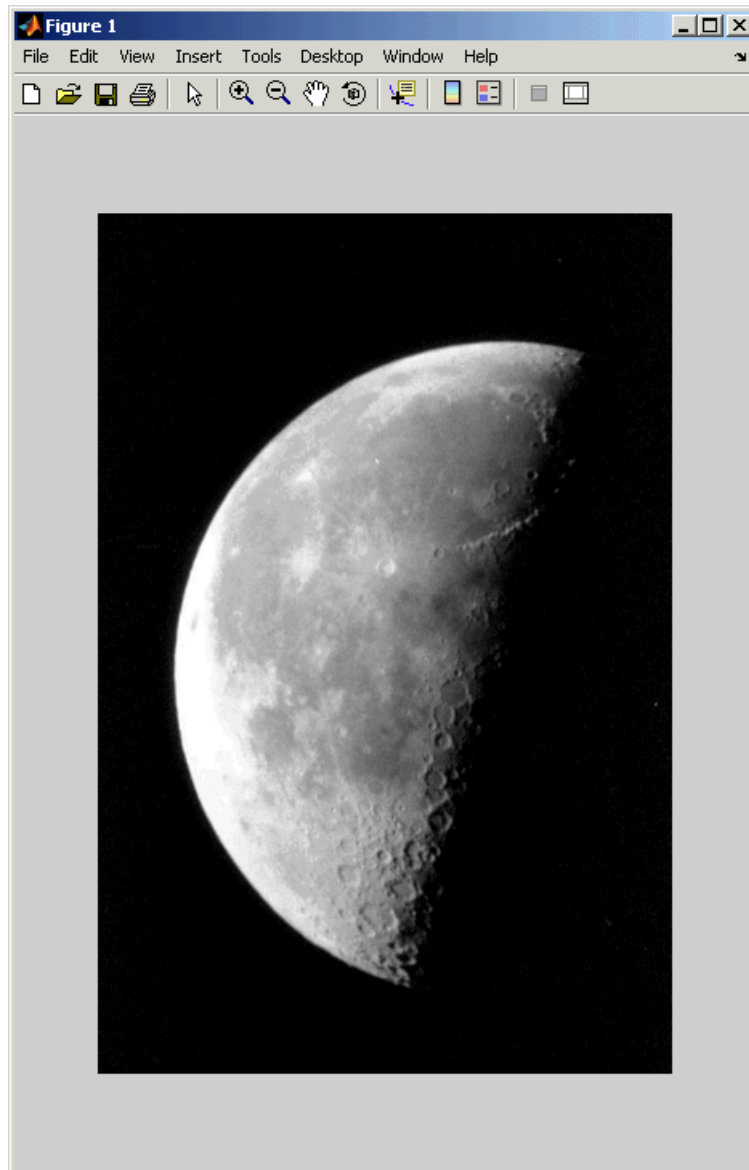
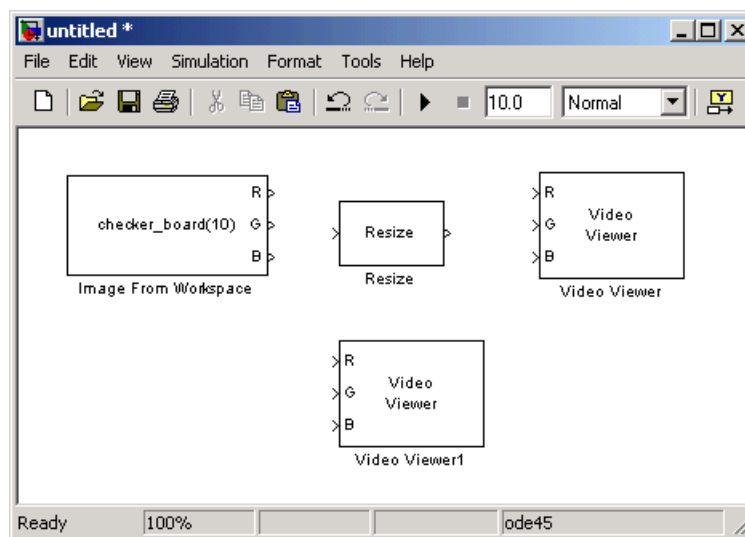

Image Courtesy of Michael Myers

- 3 Create a new Simulink model, and add the following blocks to it.

Block	Library	Quantity
Image From Workspace	Video and Image Processing Blockset / Sources	1
Resize	Video and Image Processing Blockset / Geometric Transformations	1
Video Viewer	Video and Image Processing Blockset / Sinks	2

4 Place the blocks as shown in the figure below.



5 Use the Image From Workspace block to import the intensity image from the MATLAB workspace. Set the parameters as follows:

- **Main pane, Value** = I
- **Output port labels** = Image

The block outputs the image at the Image port.

6 Use the Video Viewer1 block to display the original image. Set the **Input image type** parameter to Intensity.



The Video Viewer1 block automatically displays the original image in the Video Viewer1 window when you run the model.

- 7 Use the Resize block to shrink the image. Set the **Resize factor in %** parameter to 50.

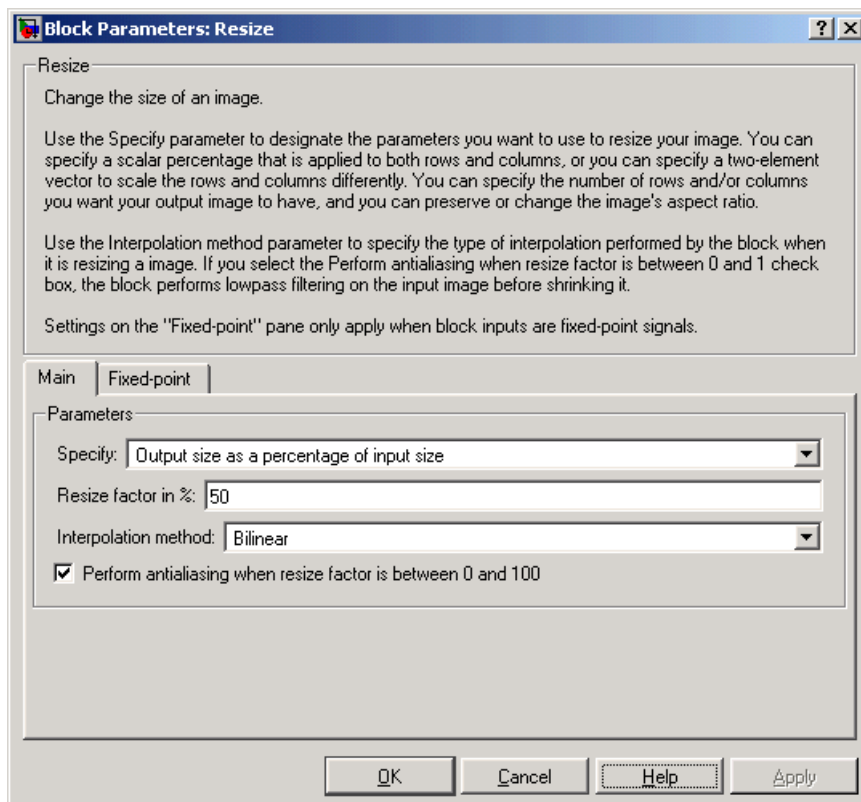

The Resize block shrinks the image to half its original size.

- 8 Use the Video Viewer block to display the modified image. Set the **Input image type** parameter to Intensity.
- 9 Connect the blocks as shown in the figure below.

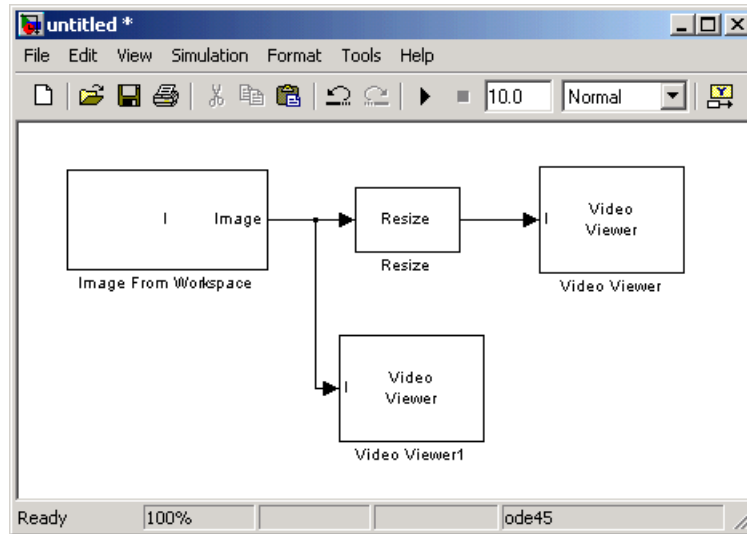

**10** Set the configuration parameters. Open the Configuration dialog box by selecting **Configuration Parameters** from the **Simulation** menu. Set the parameters as follows:

- **Solver** pane, **Stop time** = 0
- **Solver** pane, **Type** = Fixed-step
- **Solver** pane, **Solver** = discrete (no continuous states)

**11** Run the model.

The original image appears in the Video Viewer1 window. To view the image at its true size, right-click the window and select **Set Display To True Size**.



The reduced image appears in the Video Viewer window. Right-click the window and select **Set Display To True Size**. The smaller image is half the size of the original image.



In this example, you used the Resize block to shrink an image. For more information about this block, see the [Resize block reference page](#). For more information about other geometric transformation blocks, see the [Rotate, Shear, and Translate block reference pages](#).

## Cropping an Image

You can use the Selector block to crop your image or video stream. In this example, you learn how to use the Selector block to trim an image down to a particular region of interest:

- 1 Define an intensity image in the MATLAB workspace. At the MATLAB command prompt, type

```
I = imread('coins.png');
```

I is a 246-by-300 matrix of 8-bit unsigned integer values.

- 2 To view the image this matrix represents, at the MATLAB command prompt, type

```
imshow(I)
```



- 3 Create a new Simulink model, and add the following blocks to it.

Block	Library	Quantity
Image From Workspace	Video and Image Processing Blockset / Sources	1
Video Viewer	Video and Image Processing Blockset / Sinks	2
Selector	Simulink / Signal Routing	1

4 Place the blocks as shown in the figure below.

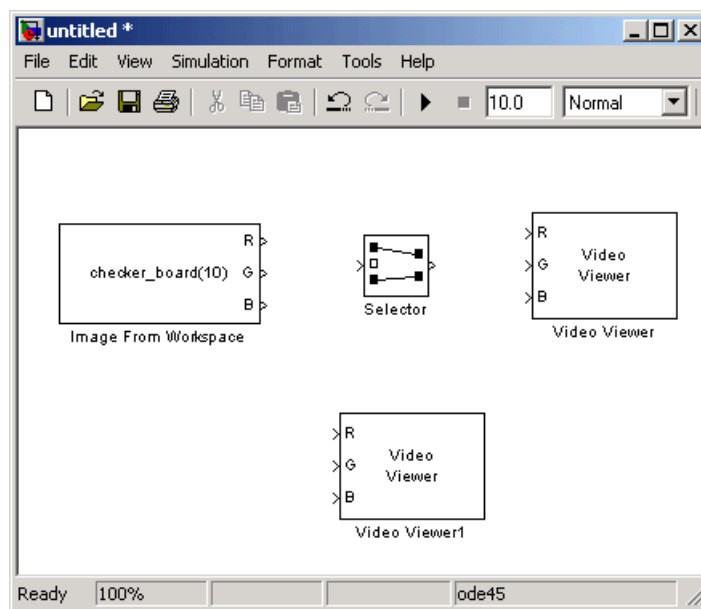

5 Use the Image From Workspace block to import the intensity image from the MATLAB workspace. Set the parameters as follows:

- **Main pane, Value = I**
- **Output port labels = Image**

The block outputs the image at the Image port.

- 6 Use the Video Viewer1 block to display the original image. Set the **Input image type** parameter to Intensity.

The Video Viewer1 block automatically displays the original image in the Video Viewer1 window when you run the model.

- 7 Use the Selector block to crop the image. Set the block parameters as follows:
  - **Input type** = Matrix
  - **Rows** = 140
  - **Columns** = 200
  - Select the **Use index as starting value** check box.
  - **Output port dimensions** = [70 70]

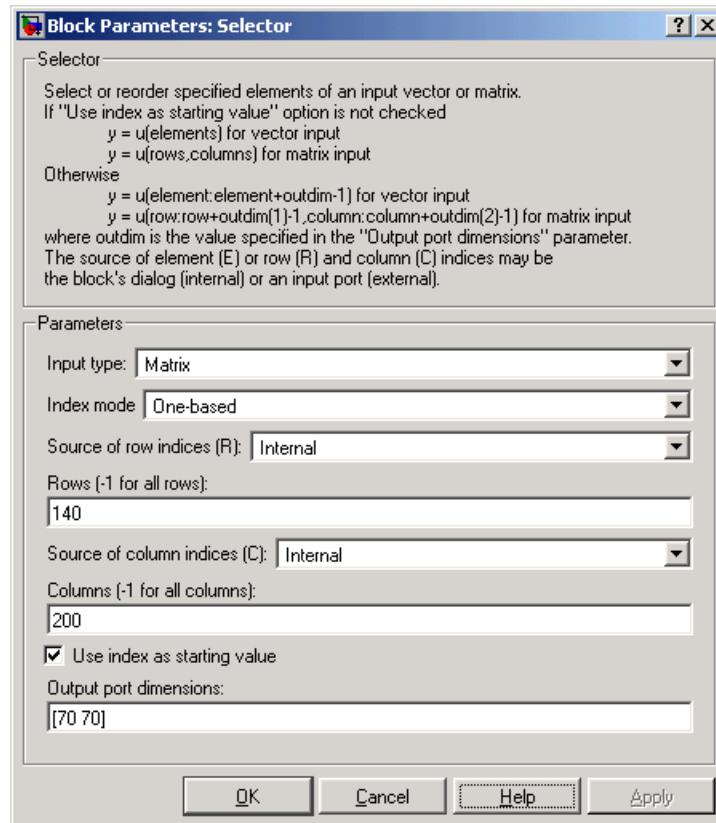

The Selector block starts at row 140 and column 200 of the image and outputs the next 70 rows and columns of the image.

- 8 Use the Video Viewer block to display the cropped image. Set the **Input image type** parameter to Intensity.

The Video Viewer block automatically displays the modified image in the Video Viewer window when you run the model.

- 9 Connect the blocks as shown in the figure below.



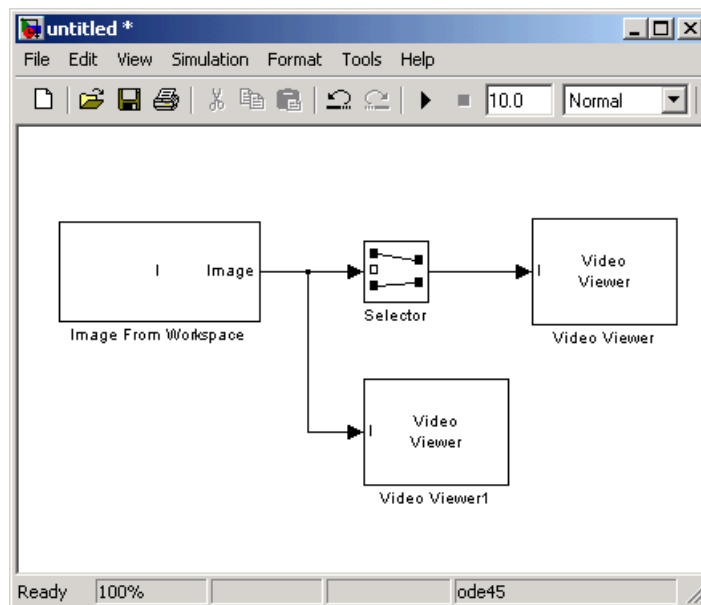

**10** Set the configuration parameters. Open the Configuration dialog box by selecting **Configuration Parameters** from the **Simulation** menu. Set the parameters as follows:

- **Solver** pane, **Stop time** = 0
- **Solver** pane, **Type** = Fixed-step
- **Solver** pane, **Solver** = discrete (no continuous states)

**11** Run the model.

The original image appears in the Video Viewer1 window. To view the image at its true size, right-click the window and select **Set Display To True Size**.



The cropped image appears in the Video Viewer window. The image below is shown at its true size.



In this example, you used the Selector block to crop an image. For more information about the Selector block, see the Simulink documentation. For information about the `imcrop` function, see the Image Processing Toolbox documentation.

# Morphological Operations

---

Morphological image analysis can be used to perform image filtering, image segmentation, and measurement operations.

“Overview of Morphology” (p. 5-2)

Learn about morphological operations and which Video and Image Processing blocks can be used to perform them

“Counting Objects in an Image” (p. 5-3)

Use the Opening and Label blocks to determine the number of spokes in a wheel

“Correcting for Nonuniform Illumination” (p. 5-11)

Use the Opening block to correct for uneven lighting in an image

## Overview of Morphology

Morphology is the study of the shape and form of objects. Morphological image analysis can be used to perform

- Object extraction
- Image filtering operations, such as removal of small objects or noise from an image
- Image segmentation operations, such as separating connected objects
- Measurement operations, such as texture analysis and shape description

The Video and Image Processing Blockset contains blocks that perform morphological operations such as erosion, dilation, opening, and closing. Often, you need to use a combination of these blocks to perform your morphological image analysis. The examples in this chapter show you how to use blocks from the Morphological Operations library to count the number of objects in an image and how to correct for uneven illumination.

For more information, see "Morphological Operations" in the Image Processing Toolbox documentation.

## Counting Objects in an Image

In this example, you import an intensity image of a wheel from the MATLAB workspace and convert it to binary. Then, using the Opening and Label blocks, you count the number of spokes in the wheel. You can use similar techniques to count objects in other intensity images. However, you might need to use additional morphological operators and different structuring elements:

- 1 Define an intensity image in the MATLAB workspace. To read in an intensity image from a PNG file, at the MATLAB command prompt, type

```
I= imread('testpat1.png');
```

I is a 256-by-256 matrix of 8-bit unsigned integers.

- 2 To view the image this matrix represents, at the MATLAB command prompt, type

```
imshow(I)
```

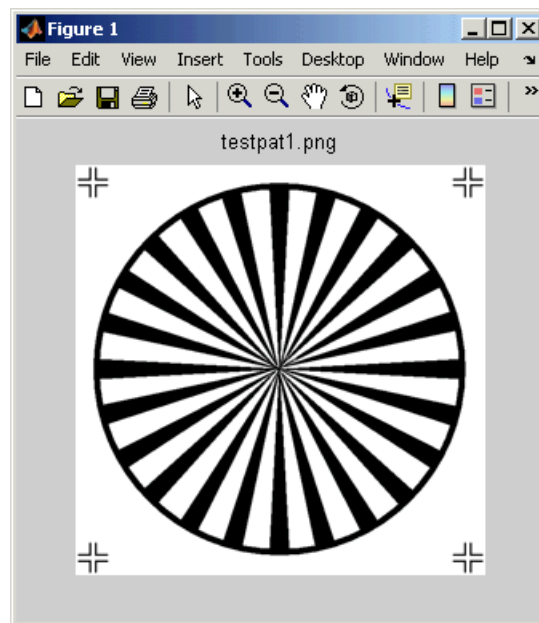

The file testpat1.png is an intensity image of a wheel that contains 24 black spokes.

- 3** Create a new Simulink model, and click-and-drag the following blocks into it.

<b>Block</b>	<b>Library</b>	<b>Quantity</b>
Image From Workspace	Video and Image Processing Blockset / Sources	1
Opening	Video and Image Processing Blockset / Morphological Operations	1
Label	Video and Image Processing Blockset / Morphological Operations	1
Video Viewer	Video and Image Processing Blockset / Sinks	2
Constant	Simulink / Sources	1
Relational Operator	Simulink / Logic and Bit Operations	1
Display	Signal Processing Blockset/ Signal Processing Sinks	1

- 4** Place the blocks so that your model resembles the following figure. The unconnected ports disappear when you set block parameters.

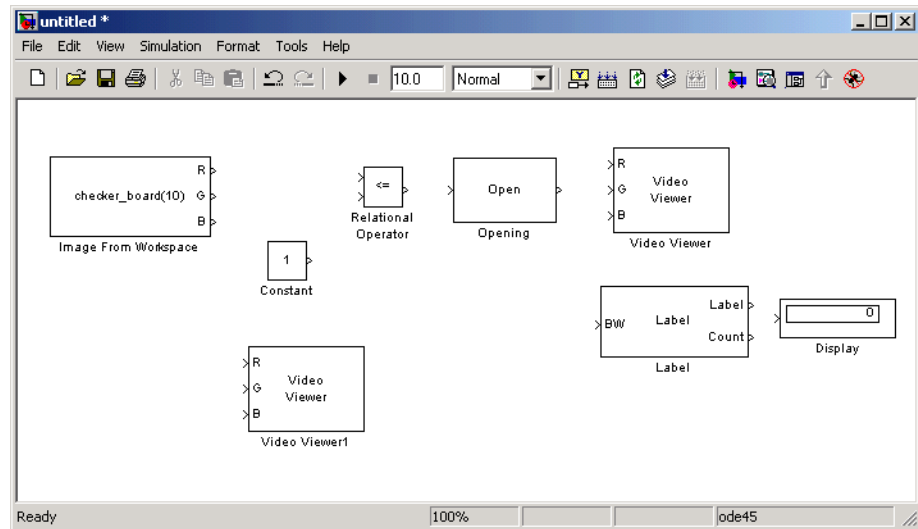

You are now ready to set your block parameters by double-clicking the blocks, modifying the block parameter values, and clicking **OK**.

- 5 Use the Image From Workspace block to import your image from the MATLAB workspace. Set the block parameters as follows:
  - **Main** pane, **Value** = I
  - **Main** pane, **Output port labels** = Image
- 6 Use the Constant block to define a threshold value for the Relational Operator block. Set the **Constant value** parameter to 200.
- 7 Use the Video Viewer1 block to view the original image. Set the **Input image type** parameter to Intensity.
- 8 Use the Relational Operator block to perform a thresholding operation that converts your intensity image to a binary image. Set the **Relational Operator** parameter to <.

If the input to the Relational Operator block is less than 200, its output is 1; otherwise, its output is 0. You must threshold your intensity image because the Label block expects binary input. Also, the objects it counts must be white.

- 9 Use the Opening block to separate the spokes from the rim and from each other at the center of the wheel. Use the default parameters.

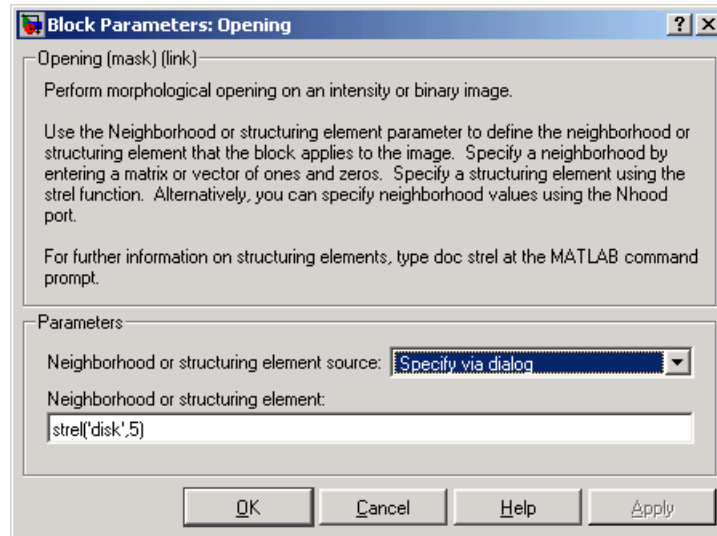

The `strel` function creates a circular STREL object with a radius of 5 pixels. When working with the Opening block, pick a STREL object that fits within the objects you want to keep. It often takes experimentation to find the neighborhood or STREL object that best suits your application.

- 10 Use the Video Viewer block to view the opened image. Set the **Input image type** parameter to Intensity.
- 11 Use the Label block to count the number of spokes in the input image. Set the **Output** parameter to Number of labels.



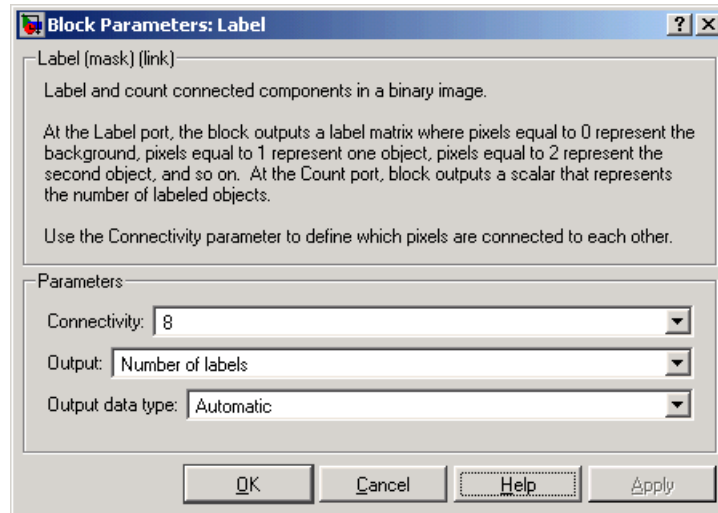

**12** The Display block displays the number of spokes in the input image. Use the default parameters.

**13** Connect the block as shown in the figure below.

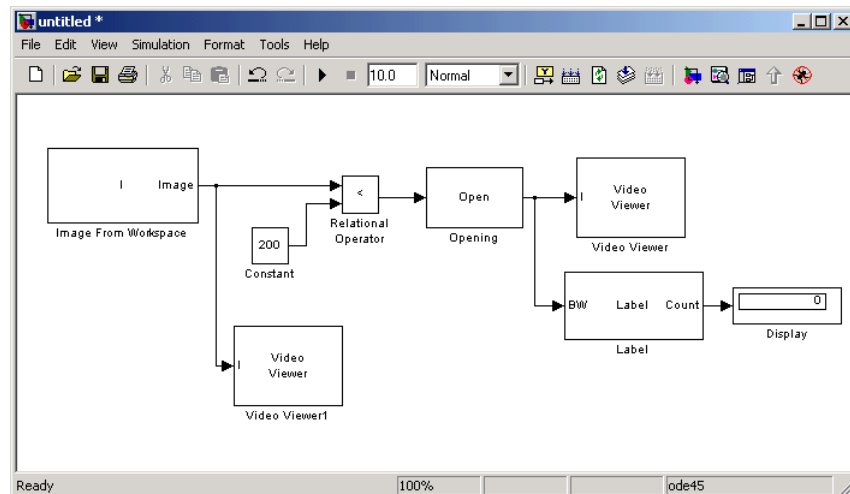

**14** Set the configuration parameters. Open the Configuration dialog box by selecting **Configuration Parameters** from the **Simulation** menu. Set the parameters as follows:

- **Solver** pane, **Stop time** = 0
- **Solver** pane, **Type** = Fixed-step
- **Solver** pane, **Solver** = discrete (no continuous states)

**15** Run the model.

The original image appears in the Video Viewer1 window. To view the image at its true size, right-click the window and select **Set Display To True Size**.

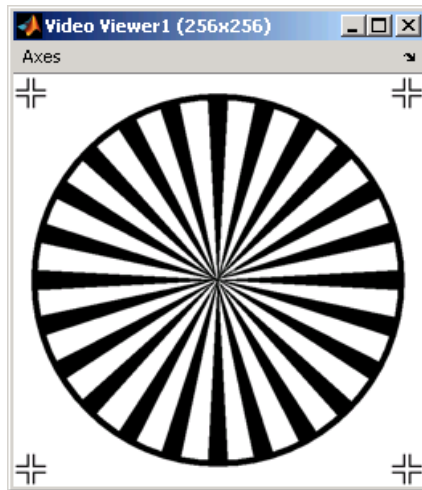

The opened image appears in the Video Viewer window. The image below is shown at its true size.

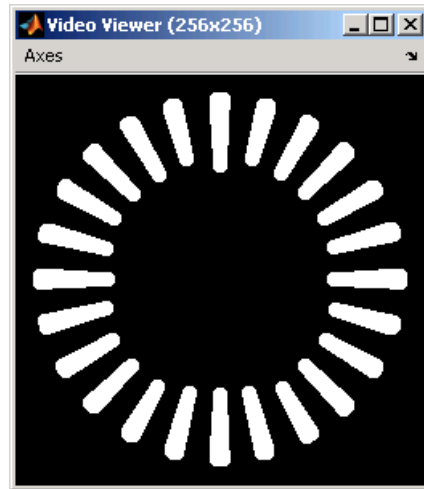

As you can see in the figure above, the spokes are now separate white objects. In the model, the Display block correctly indicates that there are 24 distinct spokes.

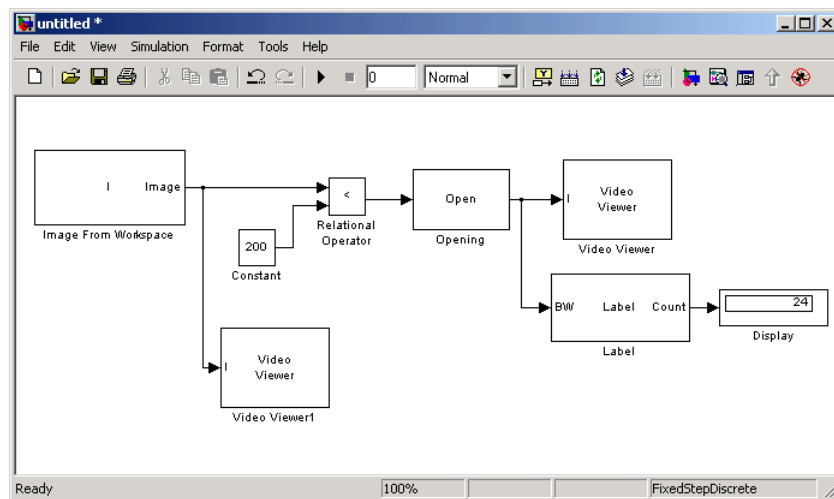

You have used the Opening and Label blocks to count the number of spokes in an image. For more information about these blocks, see the Opening and Label block reference pages. If you want to send the number of spokes

to the MATLAB workspace, use the To Workspace block in Simulink or the Signal to Workspace block in the Signal Processing Blockset. For more information about STREL objects, see `strel` in the Image Processing Toolbox documentation.

## Correcting for Nonuniform Illumination

Global threshold techniques, which are often the first step in object measurement, cannot be applied to unevenly illuminated images. To correct this problem, you can change the lighting conditions and take another picture, or you can use morphological operators to even out the lighting in the image. Once you have corrected for nonuniform illumination, you can pick a global threshold that delineates every object from the background. In this topic, you use the Opening block to correct for uneven lighting in an intensity image:

- 1 Define an intensity image in the MATLAB workspace. To read in an intensity image from a PNG file, at the MATLAB command prompt, type

```
I= imread('rice.png');
```

I is a 256-by-256 matrix of 8-bit unsigned integer values.

- 2 To view the image this matrix represents, at the MATLAB command prompt, type

```
imshow(I)
```

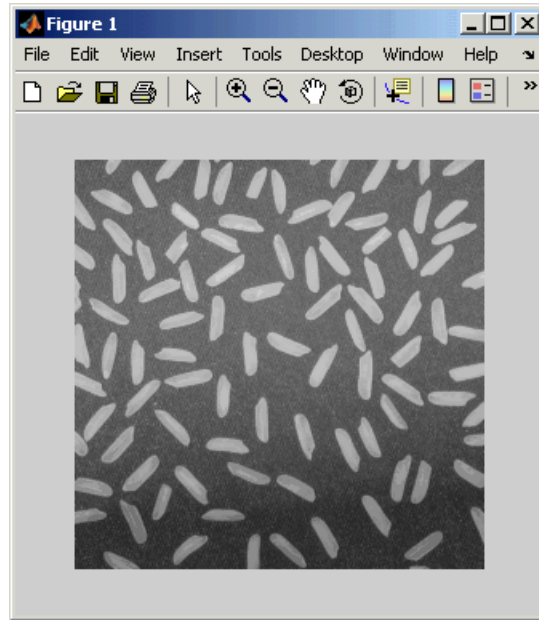

This image is darker at the bottom than at the top. You want to create a model to even out this lighting.

- 3 Create a new Simulink model, and add the following blocks to it.

Block	Library	Quantity
Image From Workspace	Video and Image Processing Blockset / Sources	1
Opening	Video and Image Processing Blockset / Morphological Operations	1
Video Viewer	Video and Image Processing Blockset / Sinks	4
Constant	Simulink / Sources	1
Sum	Simulink / Math Operations	2
Data Type Conversion	Simulink / Signal Attributes	1

- 4 Place the blocks as shown in the figure below.

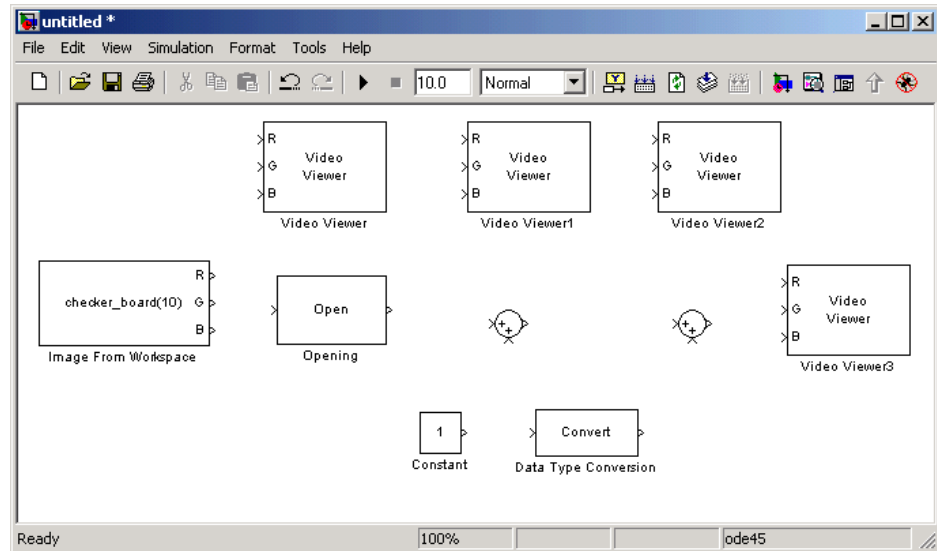

Once you have assembled the blocks required to correct for uneven illumination, you need to set your block parameters. To do this, double-click the blocks, modify the block parameter values, and click **OK**.

- 5 Use the Image From Workspace block to import the intensity image into your model. Set the block parameters as follows:
  - **Main pane, Value** = R
  - **Main pane, Output port labels** = Image
- 6 Use the Video Viewer block to view the original image. Set the **Input image type** parameter to Intensity.
- 7 Use the Opening block to estimate the background of the image. Set the **Neighborhood or structuring element** parameter to `strel('disk',15)`.

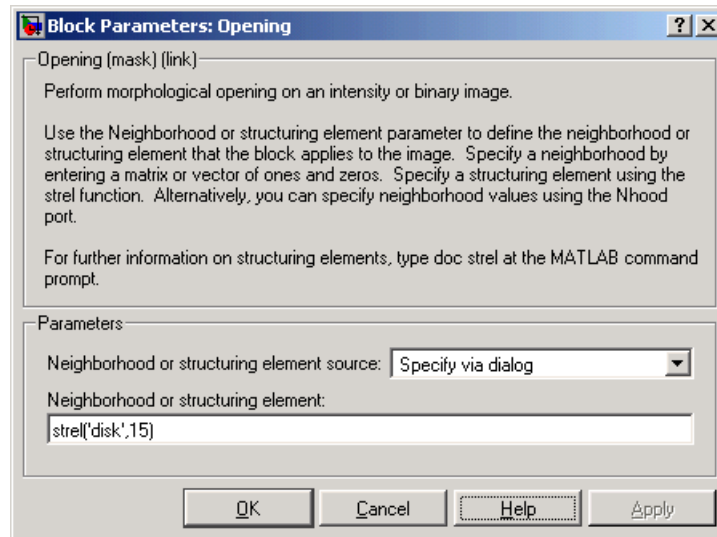

The `strel` function creates a circular STREL object with a radius of 15 pixels. When working with the Opening block, pick a STREL object that fits within the objects you want to keep. It often takes experimentation to find the neighborhood or STREL object that best suits your application.

- 8 Use the Video Viewer1 block to view the background estimated by the Opening block. Set the **Input image type** parameter to Intensity.
- 9 Use the first Sum block to subtract the estimated background from the original image. Set the block parameters as follows:
  - **Icon shape** = rectangular
  - **List of signs** = - +
- 10 Use the Video Viewer2 block to view the result of subtracting the background from the original image. Set the **Input image type** parameter to Intensity.
- 11 Use the Constant block to define an offset value. Set the **Constant value** parameter to 80.
- 12 Use the Data Type Conversion block to convert the offset value to an 8-bit unsigned integer. Set the **Output data type mode** parameter to `uint8`.



**13** Use the second Sum block to lighten the image so that it has the same brightness as the original image. Set the block parameters as follows:

- **Icon shape** = rectangular
- **List of signs** = ++

**14** Use the Video Viewer3 block to view the corrected image. Set the **Input image type** parameter to Intensity.

**15** Connect the blocks as shown in the figure below.

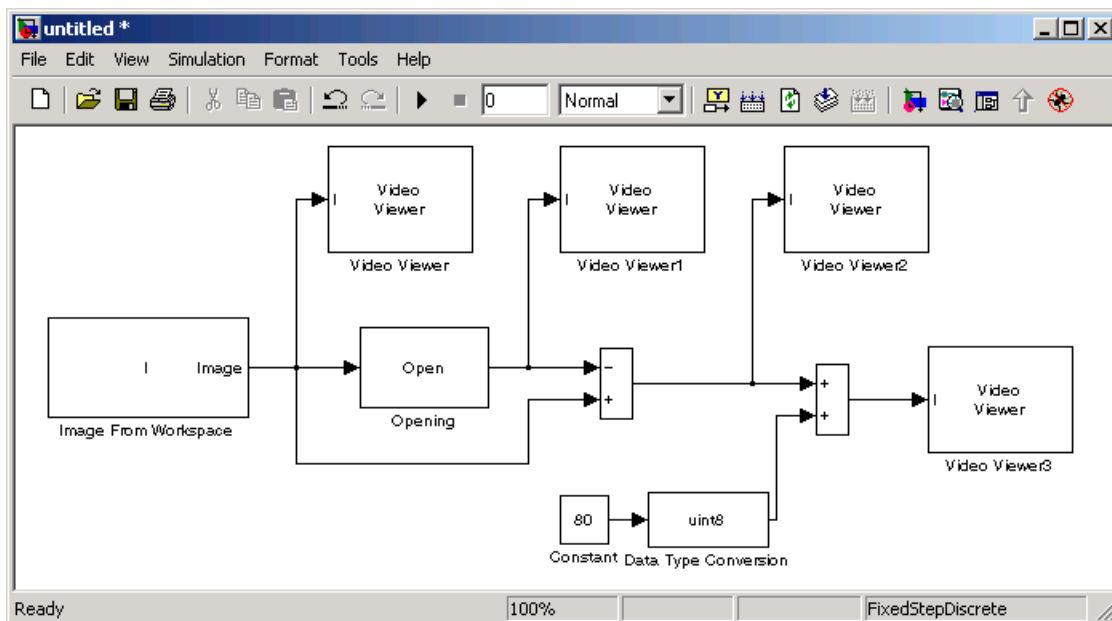

**16** Set the configuration parameters. Open the Configuration dialog box by selecting **Configuration Parameters** from the **Simulation** menu. Set the parameters as follows:

- **Solver** pane, **Stop time** = 0
- **Solver** pane, **Type** = Fixed-step
- **Solver** pane, **Solver** = discrete (no continuous states)

### 17 Run the model.

The original image appears in the Video Viewer window. To view the image at its true size, right-click the window and select **Set Display To True Size**.



The estimated background appears in the Video Viewer1 window. The image below is shown at its true size.

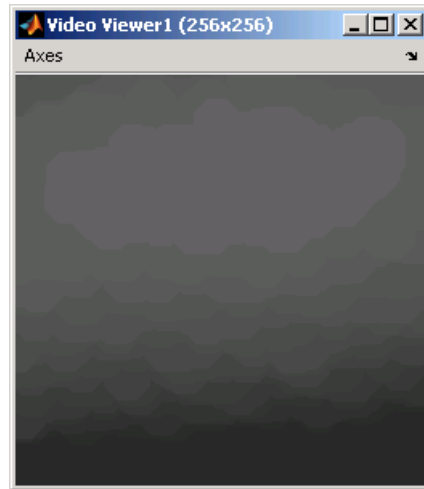

The image without the estimated background appears in the Video Viewer2 window. The image below is shown at its true size.



The image shown above is too dark. The Constant block provides an offset value that you used to brighten the image.

The corrected image appears in the Video Viewer3 window. Note that the corrected image has even lighting. The image below is shown at its true size.



In this section, you have used the Opening block to remove irregular illumination from an image. For more information about this block, see the Opening block reference page. For related information, see the Top-hat block reference page. For more information about STREL objects, see the `strel` function in the Image Processing Toolbox documentation.

# Analysis and Enhancement

---

You can use Video and Image Processing Blockset blocks to learn more about the structure of images as well as to improve them.

“Image Analysis” (p. 6-2)

Learn more about the content of images

“Image Enhancement” (p. 6-10)

Understand how to improve image characteristics

“Pixel Statistics” (p. 6-30)

Determine information about the data values that make up an image using blocks from the Statistics library

## Image Analysis

Image analysis techniques return information about the structure of an image. For example, you can use them to find edges, locations, and features of objects.

This section includes the following topic:

- “Finding Edges in an Image” on page 6-2 — Use the Edge Detection block to find object boundaries

### Finding Edges in an Image

You can use the Edge Detection block to find the edges of objects in an image. This block finds the pixel locations where the magnitude of the gradient of intensity is larger than a threshold value. These locations typically occur at the boundaries of objects. In this section, you use the Edge Detection block to find the edges of rice grains in an intensity image:

- 1** Define an intensity image in the MATLAB workspace. To read in an intensity image from a PNG file, at the MATLAB command prompt, type

```
I = imread('rice.png');
```

I is a 256-by-256 matrix of 8-bit unsigned integers.

- 2** To view the image this matrix represents, at the MATLAB command prompt, type

```
imshow(I)
```

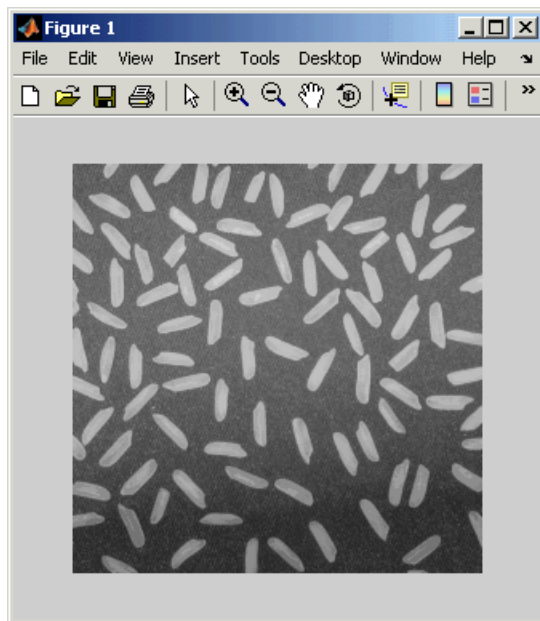

- 3 Create a new Simulink model, and add the following blocks into it.

Block	Library	Quantity
Image From Workspace	Video and Image Processing Blockset / Sources	1
Edge Detection	Video and Image Processing Blockset / Analysis & Enhancement	1
2-D Minimum	Video and Image Processing Blockset / Statistics	2
2-D Maximum	Video and Image Processing Blockset / Statistics	2
Video Viewer	Video and Image Processing Blockset / Sinks	3
Subtract	Simulink / Math Operations	2
Divide	Simulink / Math Operations	2

4 Place the blocks so that your model resembles the following figure.

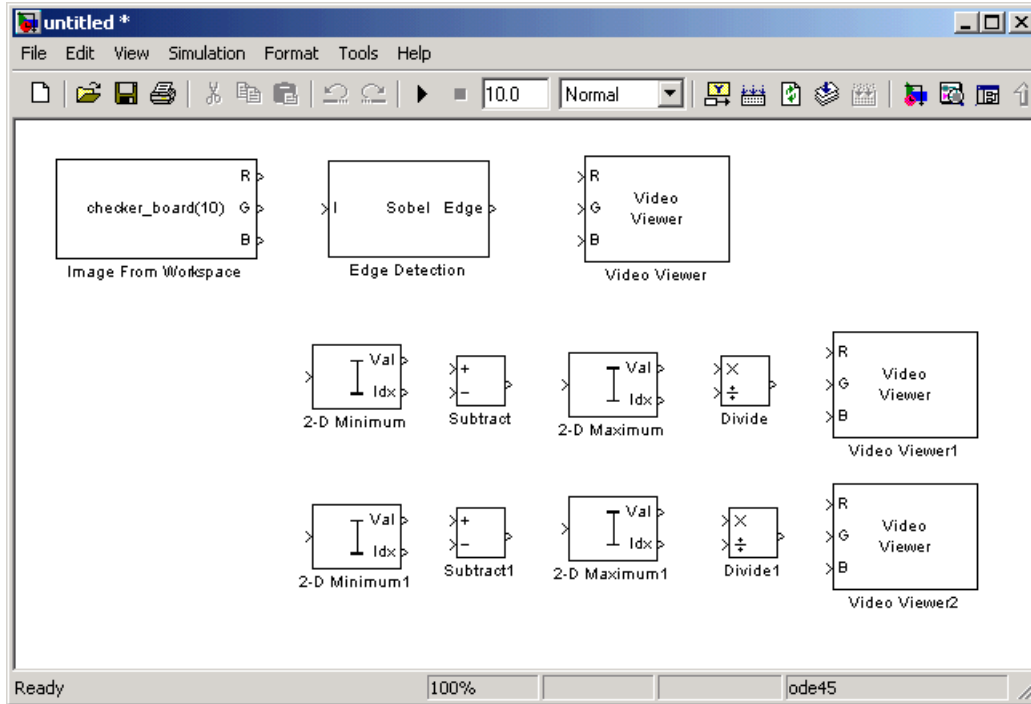

You are now ready to set your block parameters by double-clicking the blocks, modifying the block parameter values, and clicking **OK**.

- 5 Use the Image From Workspace block to import your image from the MATLAB workspace. Set the block parameters as follows:
  - **Main** pane, **Value** = I
  - **Main** pane, **Output port labels** = Image
  - **Data Types** pane, **Output data type** = double
- 6 Use the Edge Detection block to find the edges in the image. Set the block parameters as follows:
  - **Output type** = Binary image and gradient components
  - Select the **Edge thinning** check box.



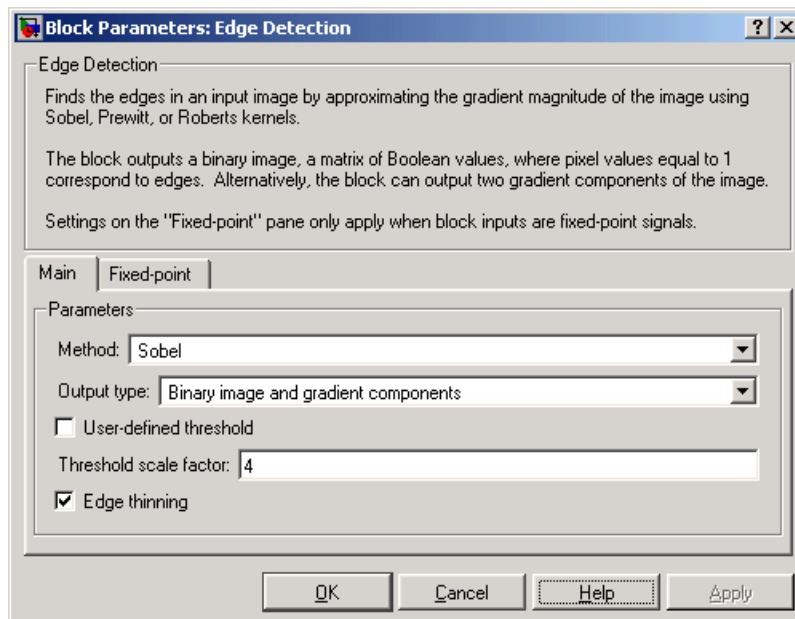

The Edge Detection block convolves the input matrix with the Sobel kernel to calculate the gradient components of the image that correspond to the horizontal and vertical edge responses. The block outputs these components at the Gh and Gv ports, respectively. Then it performs a thresholding operation on these gradient components to find the binary image, a matrix filled with ones and zeros. The nonzero elements of this matrix correspond to the edge pixels and the zero elements correspond to the background pixels. The block outputs the binary image at the Edge port.

- 7 View the binary image using the Video Viewer block. Set the **Input image type** parameter to Intensity.

The matrices output from the Gv and Gh ports of the Edge Detection block are composed of double-precision floating point values. You must scale these matrix values between 0 in 1 to display them using the Video Viewer blocks.

- 8 Use the 2-D Minimum blocks to find the minimum value of Gv and Gh matrices. Set the **Mode** parameters to Value.

- 9 Use the Subtract blocks to subtract the minimum values from each element of the Gv and Gh matrices. This process ensures that the minimum value of these matrices is 0. Use the default parameters.
- 10 Use the 2-D Maximum blocks to find the maximum value of the new Gv and Gh matrices. Set the **Mode** parameters to Value.
- 11 Use the Divide blocks to divide each element of the Gv and Gh matrices by their maximum value. This normalization process ensures that these matrices range between 0 and 1. Use the default parameters.
- 12 View the gradient components of the image using the Video Viewer1 and Video Viewer2 blocks. Set the **Input image type** parameter to Intensity.
- 13 Connect the blocks as shown in the figure below.

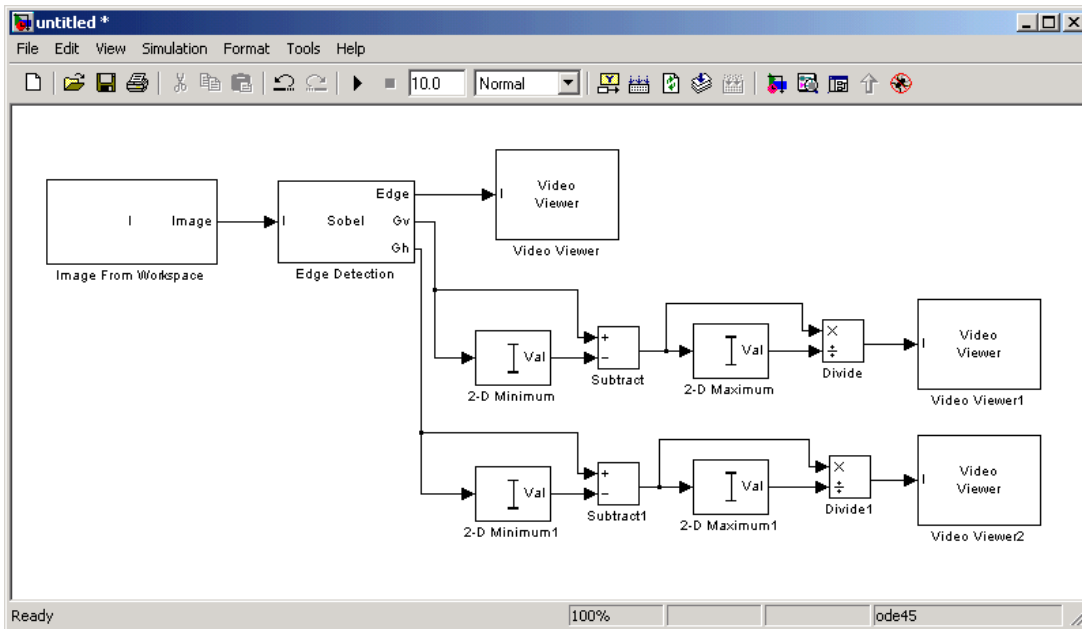

- 14 Set the configuration parameters. Open the Configuration dialog box by selecting **Configuration Parameters** from the **Simulation** menu. Set the parameters as follows:

- **Solver** pane, **Stop time** = 0
- **Solver** pane, **Type** = Fixed-step
- **Solver** pane, **Solver** = discrete (no continuous states)

**15** Run your model.

The Video Viewer window displays the edges of the rice grains in white and the background in black. To view the image at its true size, right-click the window and select **Set Display To True Size**.

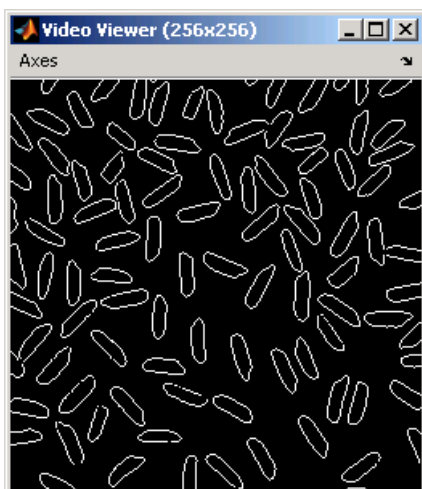

The Video Viewer1 window displays the intensity image of the vertical gradient components of the image. You can see that the vertical edges of the rice grains are darker and more well defined than the horizontal edges. The image below is shown at its true size.

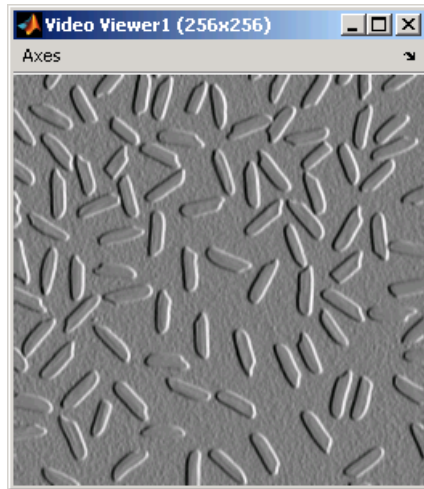

The Video Viewer2 window displays the intensity image of the horizontal gradient components of the image. In this image, the horizontal edges of the rice grains are more well defined. The image below is shown at its true size.

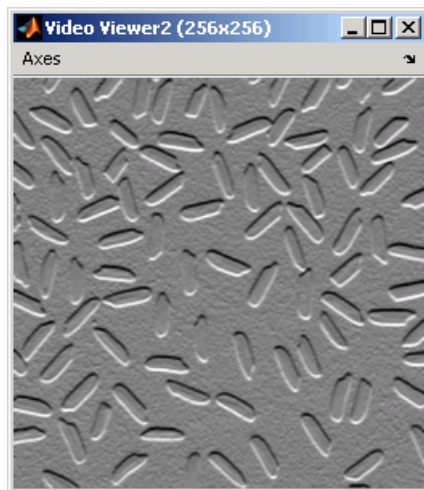

- 16** Double-click the Edge Detection block and clear the **Edge thinning** check box.
- 17** Run your model again.

Your model runs faster because the Edge Detection block is more efficient when you clear the **Edge thinning** check box. However, the edges of rice grains in the Video Viewer window are wider.

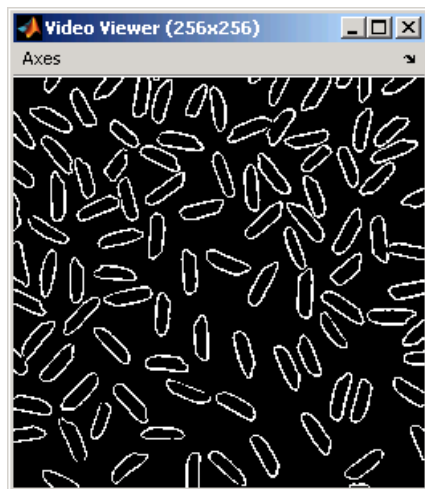

You have now used the Edge Detection block to find the object boundaries in an image. For more information on this block, see the Edge Detection block reference page.

## Image Enhancement

Image enhancement techniques improve images. You can use them to remove noise from images, increase the signal-to-noise ratio, make certain features easier to see by modifying the colors or intensities, or sharpen the image.

This section includes the following topics:

- “Sharpening and Blurring an Image” on page 6-10 — Use the 2-D FIR Filter block to improve the clarity of an image
- “Removing Salt and Pepper Noise from Images” on page 6-17 — Use the Median Filter block to eliminate noise from an intensity image
- “Removing Periodic Noise from Video” on page 6-23 — Use the 2-D FIR Filter block to eliminate noise in a video stream

### Sharpening and Blurring an Image

To sharpen a color image, you need to make the luma intensity transitions more acute, while preserving the color information of the image. To do this, you convert an R'G'B' image into the Y'CbCr color space and apply a highpass filter to the luma portion of the image only. Then, you transform the image back to the R'G'B' color space to view the results. To blur an image, you apply a lowpass filter to the luma portion of the image. This example illustrates these two processes. Note that the prime notation indicates that the signals are gamma corrected:

- 1 Define an R'G'B' image in the MATLAB workspace. To read in an R'G'B' image from a PNG file and cast it to the double-precision data type, at the MATLAB command prompt, type

```
I = im2double(imread('peppers.png'));
```

I is a 384-by-512-by-3 array of double-precision floating-point values. Each plane of this array represents the red, green, or blue color values of the image.

- 2 To view the image this array represents, at the MATLAB command prompt, type

```
imshow(I)
```

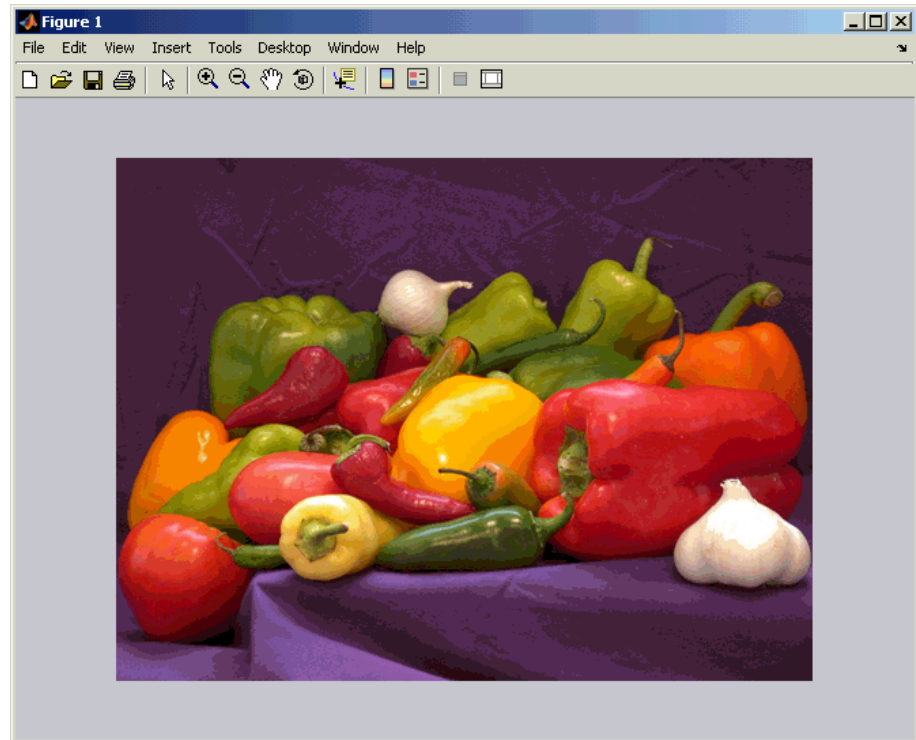

Now that you have defined your image, you can create your model.

- 3 Create a new Simulink model, and add the following blocks to it.

Block	Library	Quantity
Image From Workspace	Video and Image Processing Blockset / Sources	1
Color Space Conversion	Video and Image Processing Blockset / Conversions	2

Block	Library	Quantity
2-D FIR Filter	Video and Image Processing Blockset / Filtering	1
Video Viewer	Video and Image Processing Blockset / Sinks	1

4 Position the blocks as shown in the figure below.

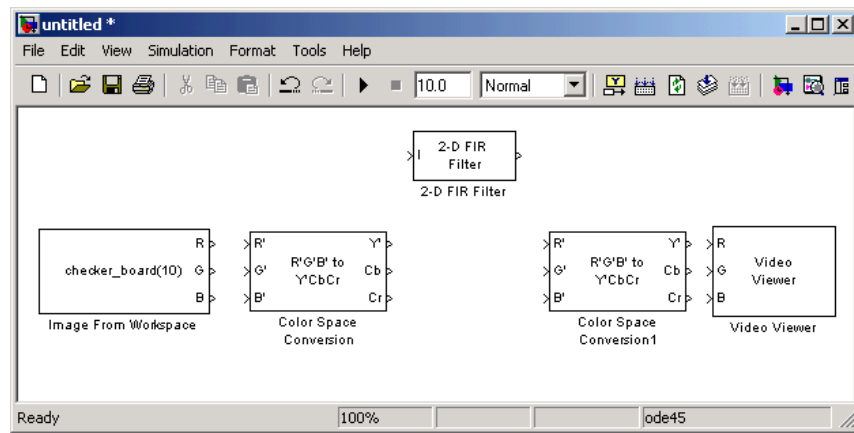

5 Use the Image From Workspace block to import the R'G'B' image from the MATLAB workspace. Set the parameters as follows:

- **Main pane, Value = I**
- **Output port labels = R' | G' | B'**

The block outputs the R', G', and B' planes of the I array at the output ports.

6 The first Color Space Conversion block converts color information from the R'G'B' color space to the YCbCr color space. Use the default parameters.



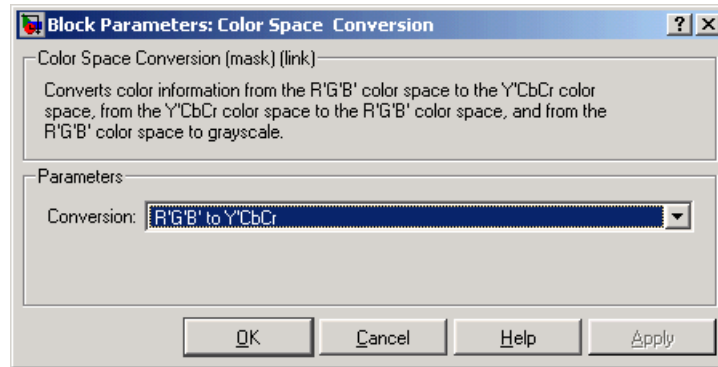

- 7 Use the 2-D FIR Filter block to filter the luma portion of the image. Set the block parameters as follows:
- **Coefficients** = `fspecial('unsharp')`
  - **Output size** = Same as input port I
  - **Padding options** = Symmetric
  - **Filtering based on** = Correlation

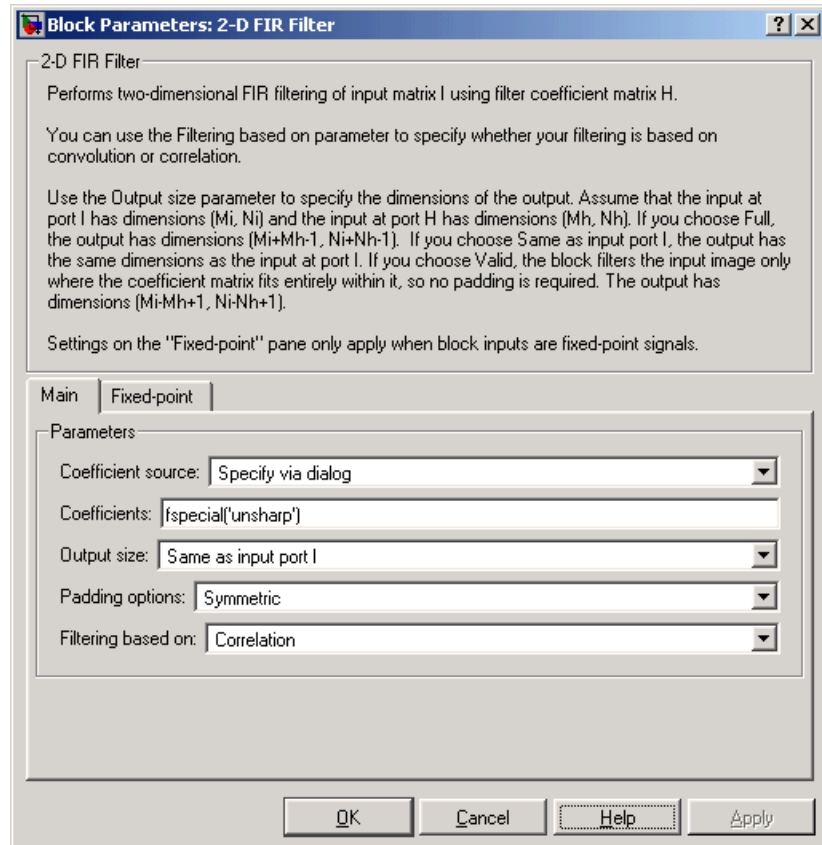

The `fspecial('unsharp')` command creates two-dimensional highpass filter coefficients suitable for correlation. This highpass filter sharpens the image by removing the low frequency noise in it.

- 8 Use the second Color Space Conversion block to convert the color information from the Y'CbCr color space to the R'G'B' color space. Set the **Conversion** parameter to Y'CbCr to R'G'B'.

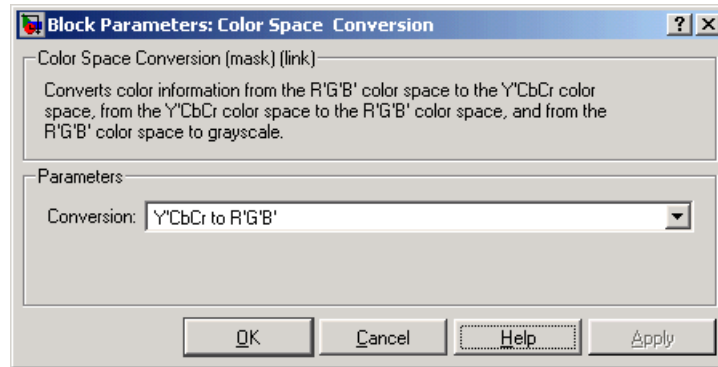

9 Use the Video Viewer block to automatically display the new, sharper image in the Video Viewer window when you run the model. Use the default parameters.

10 Connect the blocks as shown in the figure below.

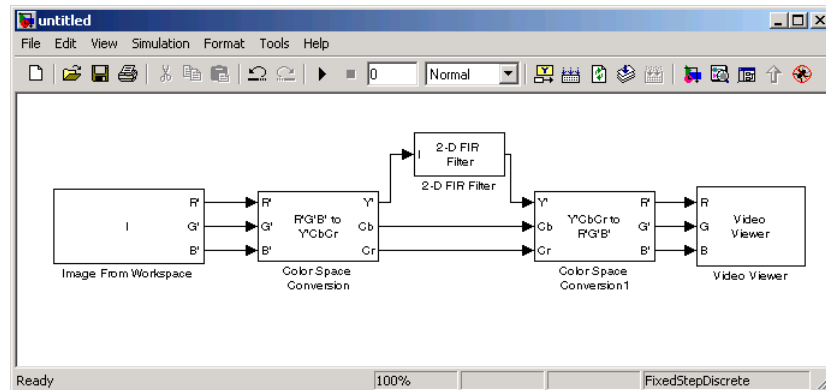

11 Set the configuration parameters. Open the Configuration dialog box by selecting **Configuration Parameters** from the **Simulation** menu. Set the parameters as follows:

- **Solver** pane, **Stop time** = 0
- **Solver** pane, **Type** = Fixed-step
- **Solver** pane, **Solver** = discrete (no continuous states)

**12** Run the model.

A sharper version of the original image appears in the Video Viewer window. To view the image at its true size, right-click the window and select **Set Display To True Size**.



**13** To blur the image, double-click the 2-D FIR Filter block. Set **Coefficients** parameter to `fspecial('gaussian',[15 15],7)` and then click **OK**.

The `fspecial('gaussian',[15 15],7)` command creates two-dimensional Gaussian lowpass filter coefficients. This lowpass filter blurs the image by removing the high frequency noise in it.

**14** Run the model.

A blurred version of the original image appears in the Video Viewer window. The image below is shown at its true size.

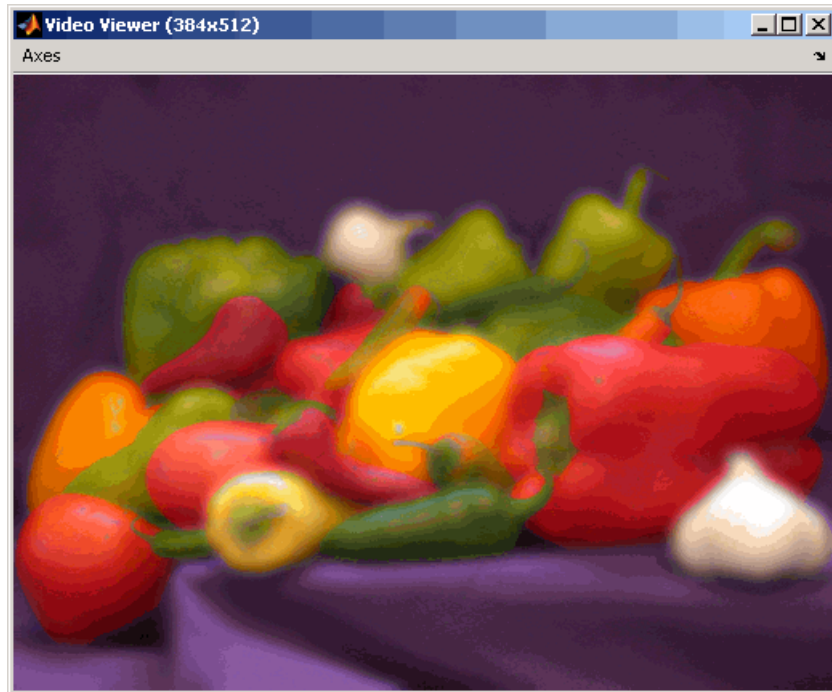

In this example, you used the Color Space Conversion and 2-D FIR Filter blocks to sharpen and blur an image. For more information on these blocks, see the Color Space Conversion and 2-D FIR Filter block reference pages. For more information on the `fspecial` function, see the Image Processing Toolbox documentation.

## Removing Salt and Pepper Noise from Images

Median filtering is a common image enhancement technique for removing salt and pepper noise. Because this filtering is less sensitive than linear techniques to extreme changes in pixel values, it can remove salt and pepper noise without significantly reducing the sharpness of an image. In this topic, you use the Median Filter block to remove salt and pepper noise from an intensity image:

- 1 Define an intensity image in the MATLAB workspace and add noise to it by typing the following at the MATLAB command prompt:

```
I= double(imread('circles.png'));
I= imnoise(I,'salt & pepper',0.02);
```

I is a 256-by-256 matrix of 8-bit unsigned integer values.

- To view the image this matrix represents, at the MATLAB command prompt, type

```
imshow(I)
```

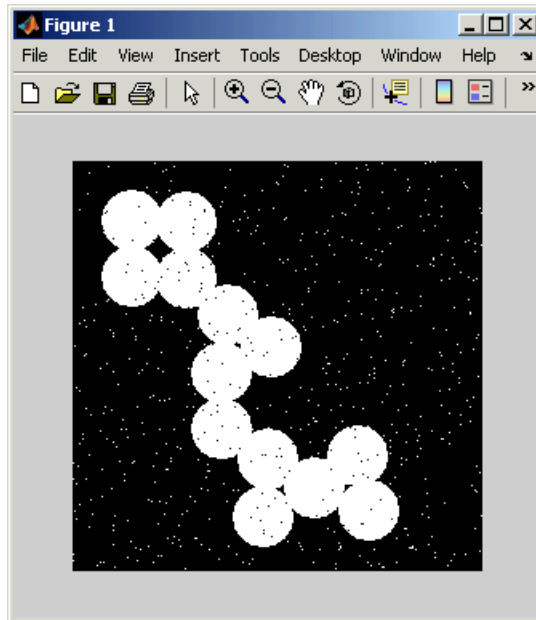

The intensity image contains noise that you want your model to eliminate.

- Create a new Simulink model, and add the following blocks to it.

Block	Library	Quantity
Image From Workspace	Video and Image Processing Blockset / Sources	1

Block	Library	Quantity
Median Filter	Video and Image Processing Blockset / Filtering	1
Video Viewer	Video and Image Processing Blockset / Sinks	2

4 Place the blocks as shown in the figure below.

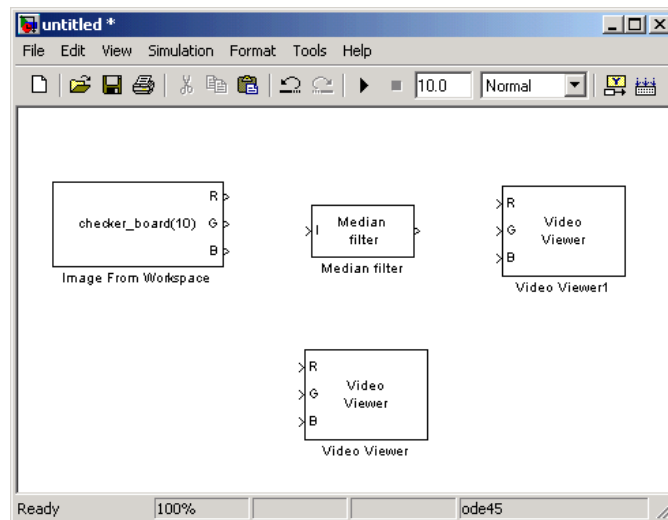

Now that you have assembled the blocks required to remove the noise in your image, you need to set your block parameters. To do this, double-click the blocks, modify the block parameter values, and click **OK**.

- 5 Use the Image From Workspace block to import the noisy image into your model. Set the block parameters as follows:
  - **Main** pane, **Value** = I
  - **Main** pane, **Output port labels** = Image
- 6 Use the Median Filter block to eliminate the black and white speckles in the image. Use the default parameters.

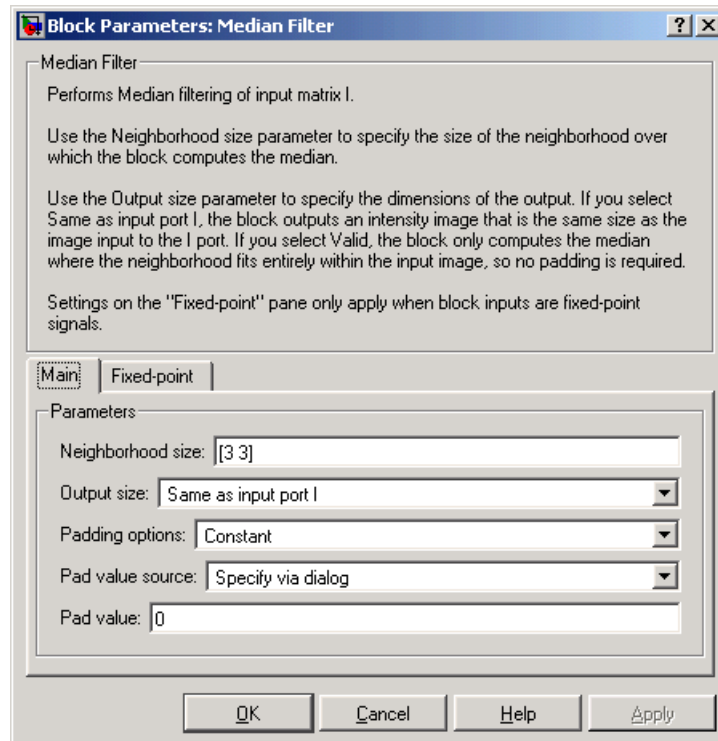

The Median Filter block replaces the central value of the 3-by-3 neighborhood with the median value of the neighborhood. This process removes the noise in the image.

- 7 Use the Video Viewer block to display the original, noisy image. Set the **Input image type** parameter to Intensity.

The Video Viewer block automatically displays the original, noisy image in the Video Viewer1 window when you run the model. Because the image is represented by 8-bit unsigned integers, a value of 0 corresponds to black and a value of 255 corresponds to white.

- 8 Use the Video Viewer1 block to display the modified image. Set the **Input image type** parameter to Intensity.
- 9 Connect the blocks as shown in the figure below.



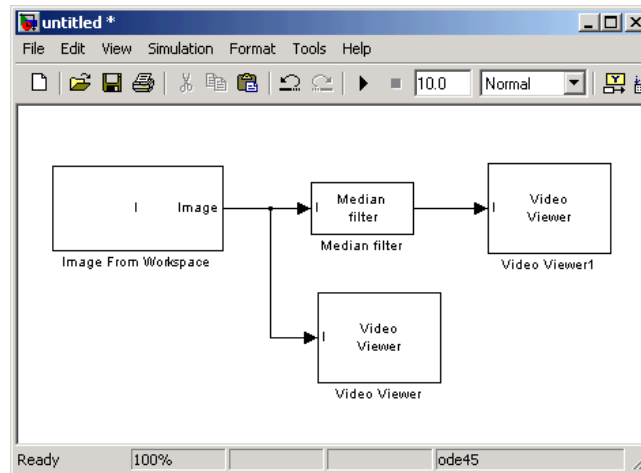

**10** Set the configuration parameters. Open the Configuration dialog box by selecting **Configuration Parameters** from the **Simulation** menu. Set the parameters as follows:

- **Solver** pane, **Stop time** = 0
- **Solver** pane, **Type** = Fixed-step
- **Solver** pane, **Solver** = discrete (no continuous states)

**11** Run the model.

The original noisy image appears in the Video Viewer window. To view the image at its true size, right-click the window and select **Set Display To True Size**.

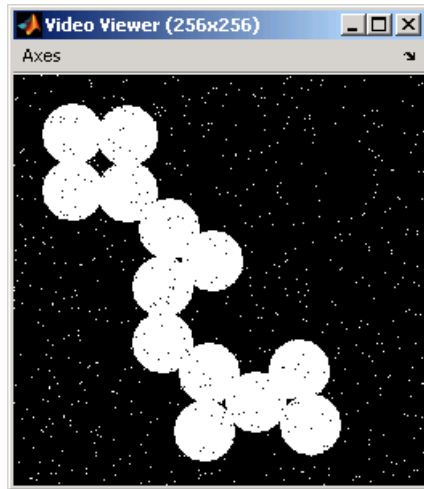

The cleaner image appears in the Video Viewer1 window. The image below is shown at its true size.

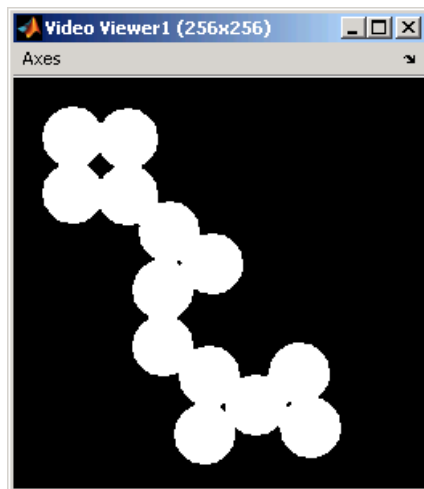

You have used the Median Filter block to remove noise from your image. For more information about this block, see the Median Filter block reference page.

## Removing Periodic Noise from Video

Periodic noise can be introduced into a video stream during acquisition or transmission due to electrical or electromechanical interference. In this example, you remove periodic noise from an intensity video using the 2-D FIR Filter block. You can use this technique to remove noise from other images or video streams, but you might need to modify the filter coefficients to account for the noise frequency content present in your signal:

- 1 Create a new Simulink model, and click-and-drag the following blocks into it.

Block	Library	Quantity
Read AVI File	Video and Image Processing Blockset / Sources	1
2-D FIR Filter	Video and Image Processing Blockset / Filtering	1
Video Viewer	Video and Image Processing Blockset / Sinks	3
Add	Simulink / Math Operations	1

- 2 Open the Periodic noise reduction demo by typing `vipstripes` at the MATLAB command prompt.
- 3 Click-and-drag the `pnoise` block into your model.

The block outputs a sinusoid with a normalized frequency that ranges between  $0.61\pi$  and  $0.69\pi$  radians per sample and a phase that varies between 0 and 3 radians. You are using this sinusoid to represent periodic noise.

- 4 Place the blocks so that your model resembles the following figure. The unconnected ports disappear when you set block parameters.

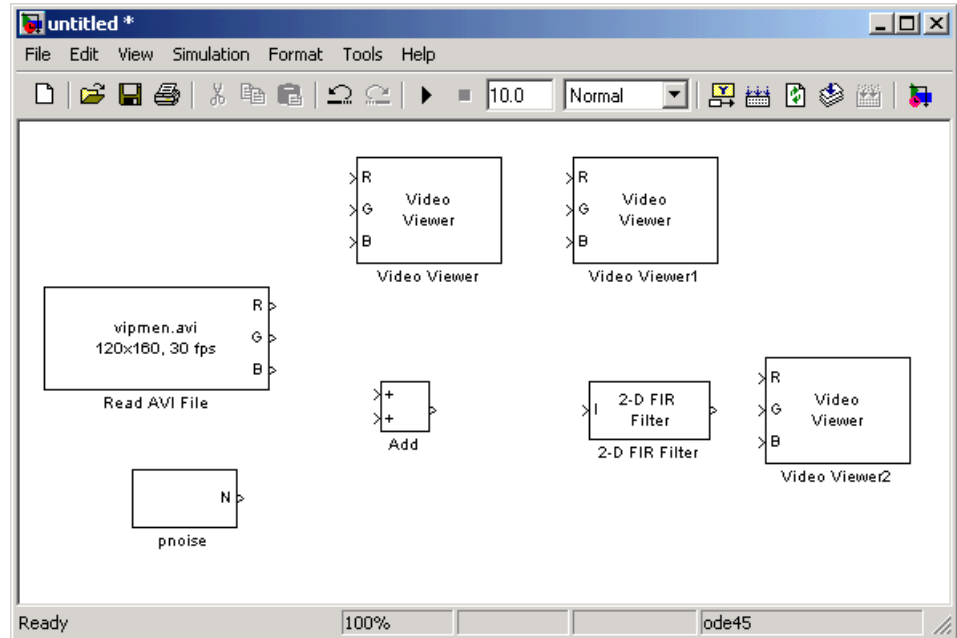

You are now ready to set your block parameters by double-clicking the blocks, modifying the block parameter values, and clicking **OK**.

- 5 Use the Read AVI File block to import an AVI file into the model. Set the block parameters as follows:
  - **Signal** = cat\_video.avi
  - **Video output data type** = double
- 6 Use the Video Viewer block to view the original video. Set the **Input image type** parameter to Intensity.
- 7 Use the Add block to add the noise video to the original video. Use the default parameters.
- 8 Use the Video Viewer1 block to view the noisy video. Set the **Input image type** parameter to Intensity.
- 9 Define the filter coefficients in the MATLAB workspace. Type the following code at the MATLAB command prompt:

`vipdh_stripes`

The variable `h`, as well as several others, are loaded into the MATLAB workspace. The variable `h` represents the coefficients of the band reject filter capable of removing normalized frequencies between  $0.61\pi$  and  $0.69\pi$  radians per sample. The coefficients were created using the Filter Design and Analysis Tool (FDATool) and the `ftrans2` function.

**10** Use the 2-D FIR Filter block to model a band-reject filter capable of removing the periodic noise from the video. Set the block parameters as follows:

- **Coefficients** = `h`
- **Output size** = Same as input port 1
- **Padding options** = Circular

Choose a type of padding that minimizes the effect of the pixels outside the image on the processing of the image. In this example, circular padding produces the best results because it is most effective at replicating the sinusoidal noise outside the image.

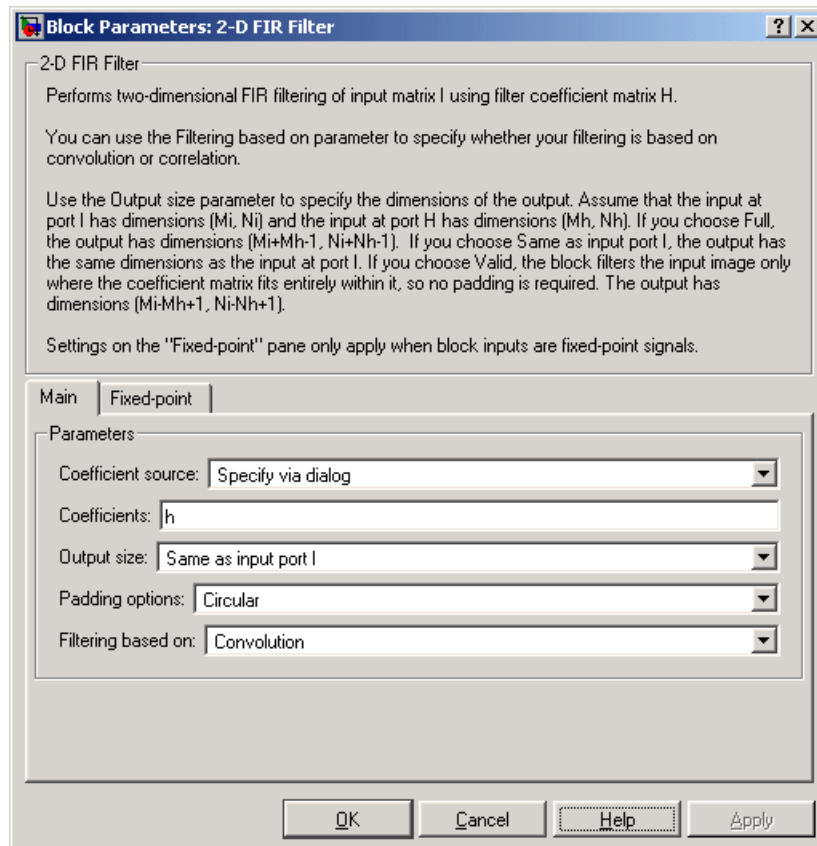

**11** Use the Video Viewer2 block to view the approximation of the original video. Set the **Input image type** parameter to Intensity.

**12** Connect the block as shown in the figure below.

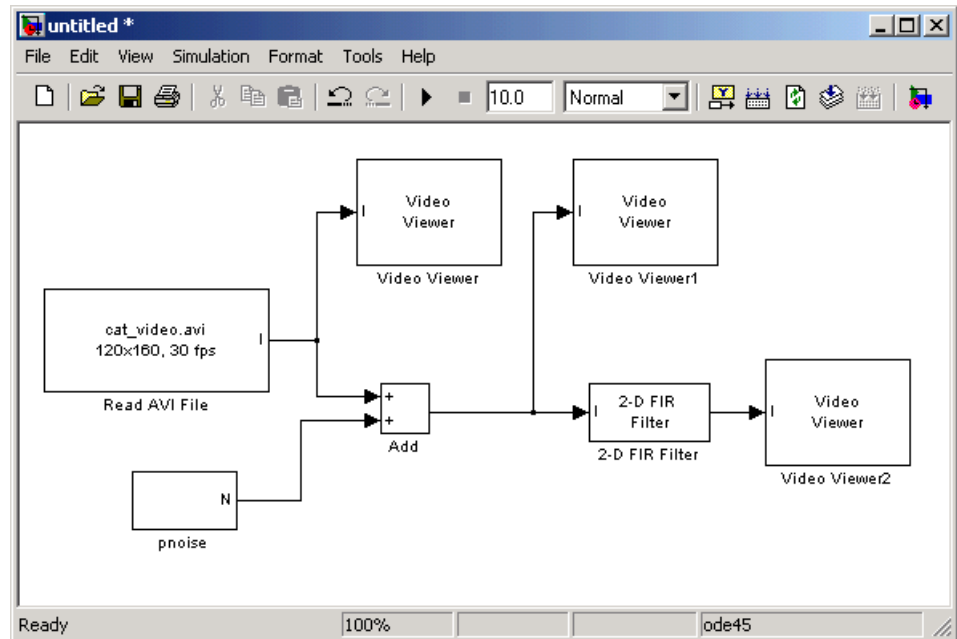

**13** Set the configuration parameters. Open the Configuration dialog box by selecting **Configuration Parameters** from the **Simulation** menu. Set the parameters as follows:

- **Solver** pane, **Stop time** = inf
- **Solver** pane, **Type** = Fixed-step
- **Solver** pane, **Solver** = discrete (no continuous states)

**14** Run the model.

The original video appears in the Video Viewer window. To view the video at its true size, right-click the window and select **Set Display To True Size**.

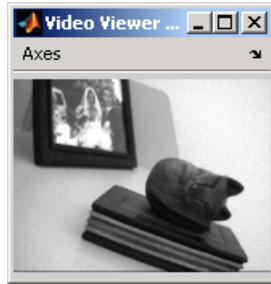

The noisy video appears in the Video Viewer1 window. The video below is shown at its true size.

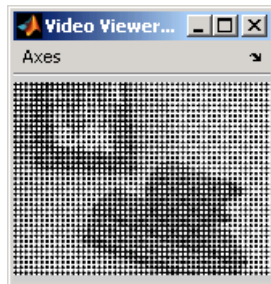

The approximation of the original video appears in the Video Viewer2 window. Note that artifacts of the processing appear near the edges of the video. The video below is shown at its true size.

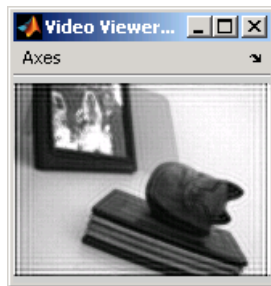

You have used the Read AVI File block to import a video into your model, the 2-D FIR Filter to remove periodic noise from this video, and the Video Viewer block to display the results. For more information about these blocks, see the Read AVI File, 2-D FIR Filter, and Video Viewer block reference pages. For



more information about the Filter Design and Analysis Tool (FDATool), see the Signal Processing Toolbox documentation. For information about the `ftrans2` function, see the Image Processing Toolbox documentation.

## Pixel Statistics

The Video and Image Processing Blockset contains blocks that can provide information about the data values that make up an image. Blocks from the Statistics library, such as the 2-D Maximum and 2-D Autocorrelation blocks, can help you determine this information.

This section includes the following topic:

- “Finding the Histogram of an Image” on page 6-30 — Use the 2-D Histogram block to calculate the histogram of the R, G, and B values in an image

### Finding the Histogram of an Image

The 2-D Histogram block computes the frequency distribution of the elements in each input image by sorting the elements into a specified number of discrete bins. You can use the 2-D Histogram block to calculate the histogram of the R, G, and/or B values in an image. This examples shows you how to accomplish this task:

- 1** Define an RGB image in the MATLAB workspace. To read in an RGB image from a PNG file, at the MATLAB command prompt, type

```
I= im2double(imread('peppers.png'));
```

I is a 486-by-732-by-3 array of double-precision floating-point values. Each plane of the array represents the red, green, or blue color values of the image.

- 2** To view the image this matrix represents, at the MATLAB command prompt, type

```
imshow(I)
```

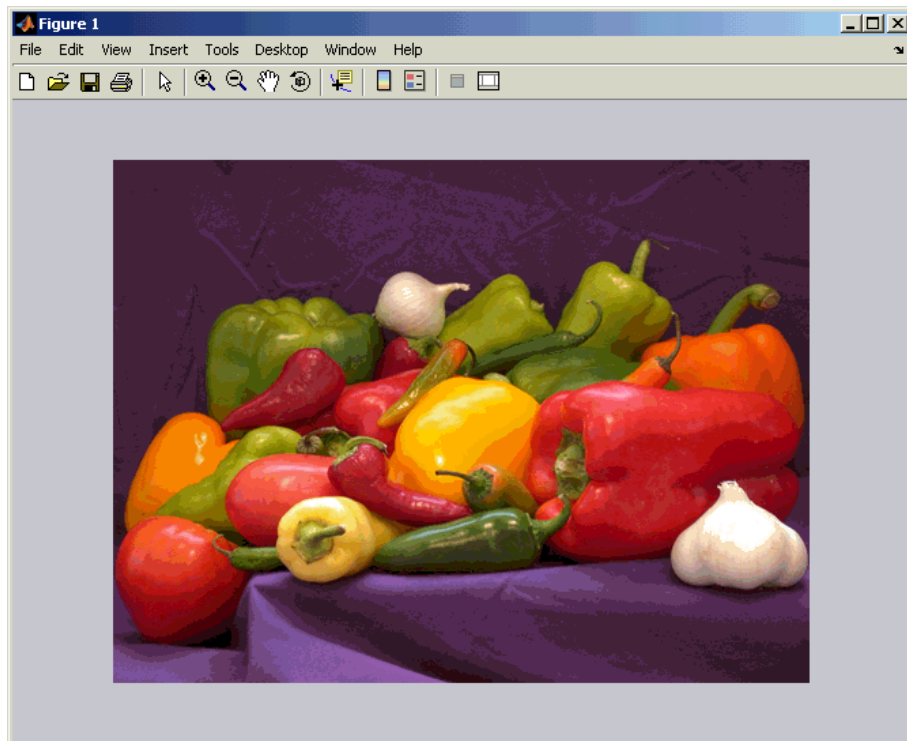

3 Create a new Simulink model, and add the following blocks into it.

Block	Library	Quantity
Image From Workspace	Video and Image Processing Blockset / Sources	1
2-D Histogram	Video and Image Processing Blockset / Statistics	1
Video Viewer	Video and Image Processing Blockset / Sinks	1
Bus Creator	Simulink / Signal Routing	1
Bus Selector	Simulink / Signal Routing	1
Reshape	Simulink / Math Operations	3

Block	Library	Quantity
Matrix Concatenation	Simulink / Math Operations	1
Vector Scope	Signal Processing Blockset / Signal Processing Sinks	1

4 Place the blocks so that your model resembles the following figure.

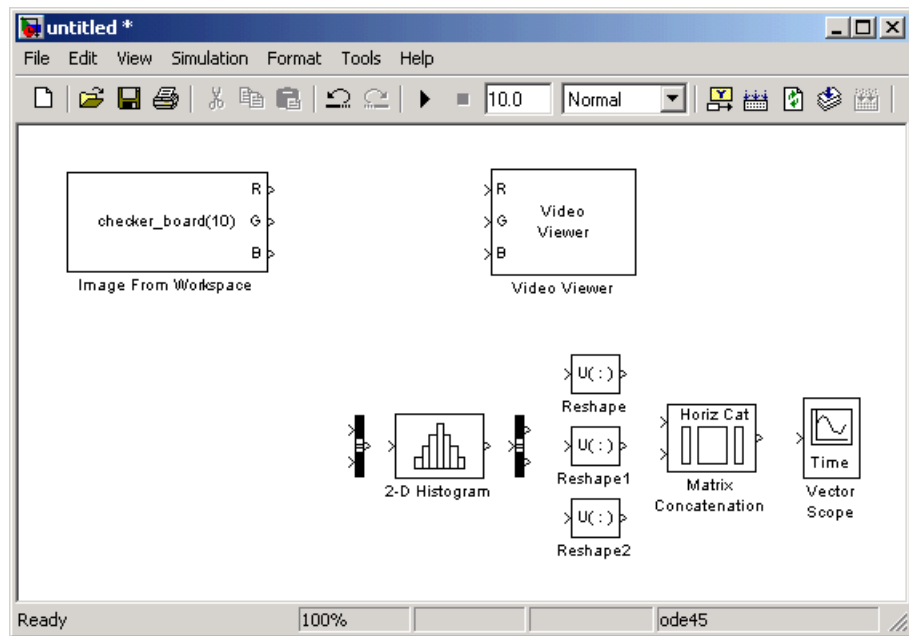

5 Use the Image From Workspace block to import the RGB image from the MATLAB workspace. Set the **Value** parameter to I.

The block outputs the R, G, and B planes of the I array at the output ports.

6 Use the Video Viewer block to automatically display the original image in the Video Viewer window when you run the model. Use the default parameters.

- 7 Use the Bus Creator block to combine the R, G, and B, signals into one signal so you can process it with one 2-D Histogram block. Set the **Number of inputs** parameter to 3.
- 8 Use the 2-D Histogram block to calculate the histogram of the R, G, and B values in the image. Use the default parameters.

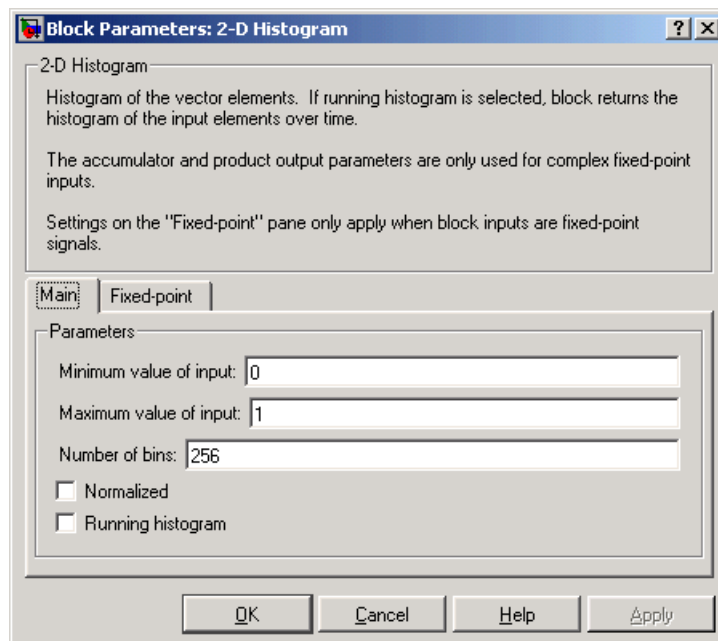

The R, G, and B values input to the 2-D Histogram block are double-precision floating point and range between 0 and 1. The block creates 256 bins between the maximum and minimum input values and counts the number of R, G, and B values in each bin.

- 9 Use the Bus Selector block to expand the input signal into three separate R, G, and B, signals. You must set the block parameters of this block after you connect a signal to its input port. You configure this block later in this procedure.

- 10 Use the Reshape blocks to transform the row vectors output from the Bus Selector block into column vectors. Set the **Output dimensionality** parameters to Column vector.
- 11 Use the Matrix Concatenation block to concatenate the R, G, and B column vectors into a single matrix so they can be displayed using the Vector Scope block. Set the **Number of inputs** parameter to 3.
- 12 Use the Vector Scope block to display the histograms of the R, G, and B values of the input image. Set the block parameters as follows:
  - **Scope Properties** pane, **Input domain** = User-defined
  - **Display Properties** pane, clear the **Frame number** check box
  - **Display Properties** pane, select the **Channel legend** check box
  - **Display Properties** pane, select the **Compact display** check box
  - **Axis Properties** pane, clear the **Inherit sample increment from input** check box.
  - **Axis Properties** pane, **Minimum Y-limit** = 0
  - **Axis Properties** pane, **Maximum Y-limit** = 1
  - **Axis Properties** pane, **Y-axis title** = Count
  - **Line Properties** pane, **Line markers** = . | s | d
  - **Line Properties** pane, **Line colors** = [1 0 0] | [0 1 0] | [0 0 1]
- 13 Connect the blocks as shown in the following figure.

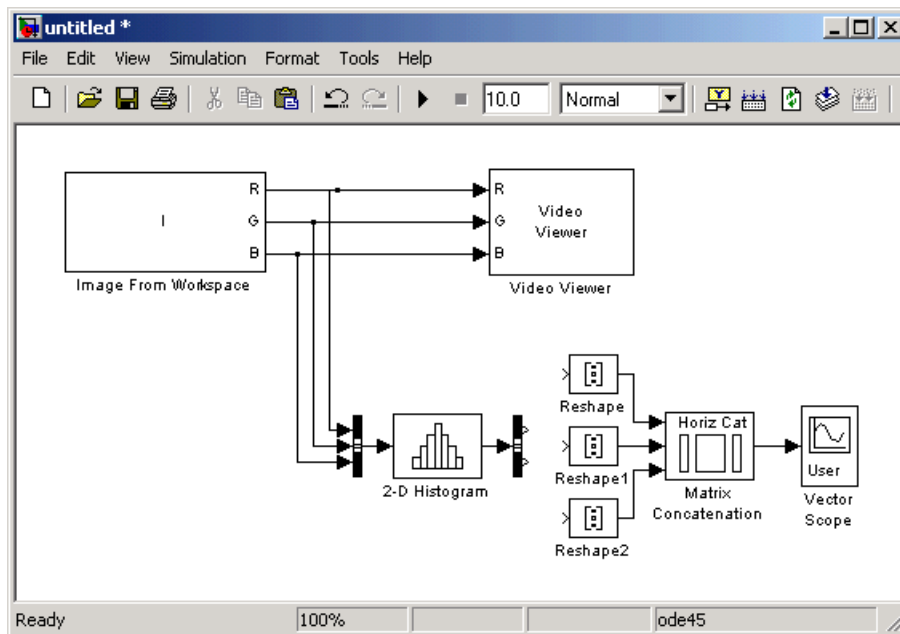

Note that the Bus Selector block still needs to be connected. You cannot configure the parameters of this block until you connect an input signal to it.

- 14** Configure the Bus Selector block. Double-click the block. In the **Signals in the bus** pane, select signal13. Click **Select** to move signal13 to the **Selected signals** pane. Click **OK**.

The Bus Selector block now has three output ports.

- 15** Connect the Bus Selector block to the Reshape blocks.
- 16** Set the configuration parameters. Open the Configuration dialog box by selecting **Configuration Parameters** from the **Simulation** menu. Set the parameters as follows:
  - **Solver** pane, **Stop time** = 0
  - **Solver** pane, **Type** = Fixed-step
  - **Solver** pane, **Solver** = discrete (no continuous states)

**17** Run the model.

The original image appears in the Video Viewer window. To view the image at its true size, right-click the window and select **Set Display To True Size**.



**18** Right-click in the Vector Scope window and select **Autoscale**.

The scaled histogram of the image appears in the Vector Scope window.



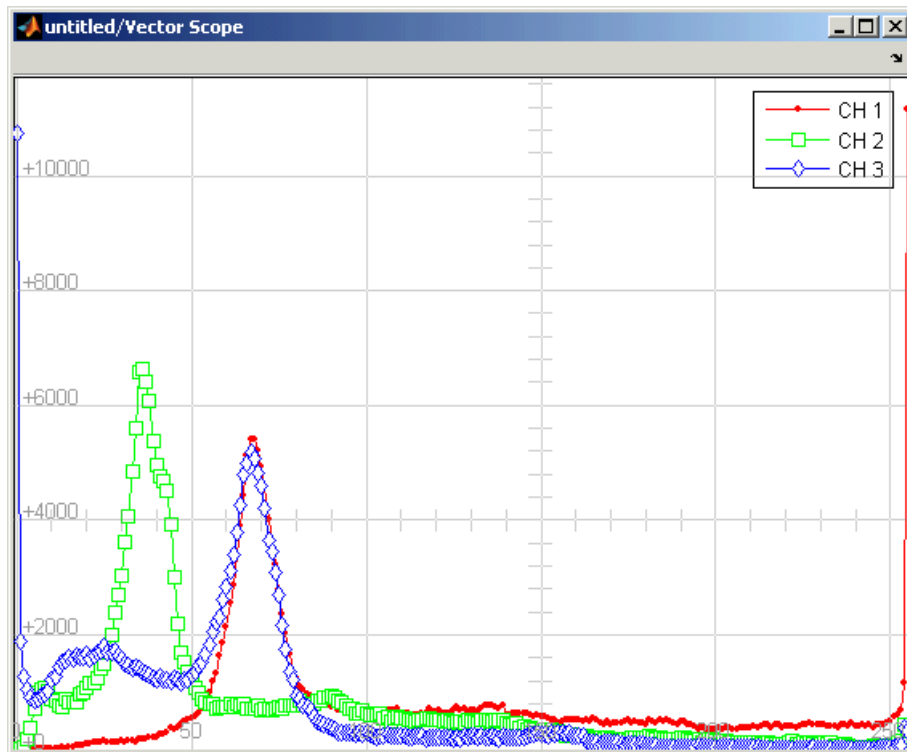

You have now used the 2-D Histogram block to calculate the histogram of the R, G, and B values in an RGB image. For more information about this block, see the 2-D Histogram block reference page. To open a demo model that illustrates how to use this block to calculate the histogram of the R, G, and B values in an RGB video stream, type `viphistogram` at the MATLAB command prompt.



# Example Applications

---

Video and Image Processing Blockset blocks enable you to track objects in an image, stabilize a video stream, and compress images.

“Pattern Matching” (p. 7-2)

Learn how to track the motion of a sculpture in a video stream

“Motion Compensation” (p. 7-8)

Explore the video compression and stabilization demo models.

“Image Compression” (p. 7-10)

Understand how to compress an image and view the result

## Pattern Matching

Pattern matching can be used to recognize and/or locate specific objects in an image. It can be accomplished using several techniques, one of which is correlation. Correlation provides a direct measure of the similarity between two images. Though sensitive to the scaling or rotation of objects, normalized correlation is robust to changes in lighting.

This section includes the following topic:

- “Tracking an Object Using Correlation” on page 7-2– Use the 2-D Correlation, 2-D Maximum, and Draw Shapes blocks to track the motion of an object in a video stream

### Tracking an Object Using Correlation

In this example, you use the 2-D Correlation, 2-D Maximum, and Draw Shapes blocks to find and indicate the location of a sculpture in each video frame:

- 1 Create a new Simulink model, and add the following blocks to it.

Block	Library	Quantity
Read AVI File	Video and Image Processing Blockset / Sources	1
Image From File	Video and Image Processing Blockset / Sources	1
2-D Correlation	Video and Image Processing Blockset / Statistics	1
2-D Maximum	Video and Image Processing Blockset / Statistics	1
Draw Shapes	Video and Image Processing Blockset / Text & Graphics	1
Video Viewer	Video and Image Processing Blockset / Sinks	1
Data Type Conversion	Simulink / Signal Attributes	1

Block	Library	Quantity
Constant	Simulink / Sources	1
Mux	Simulink / Signal Routing	1

2 Place the blocks as shown in the figure below.

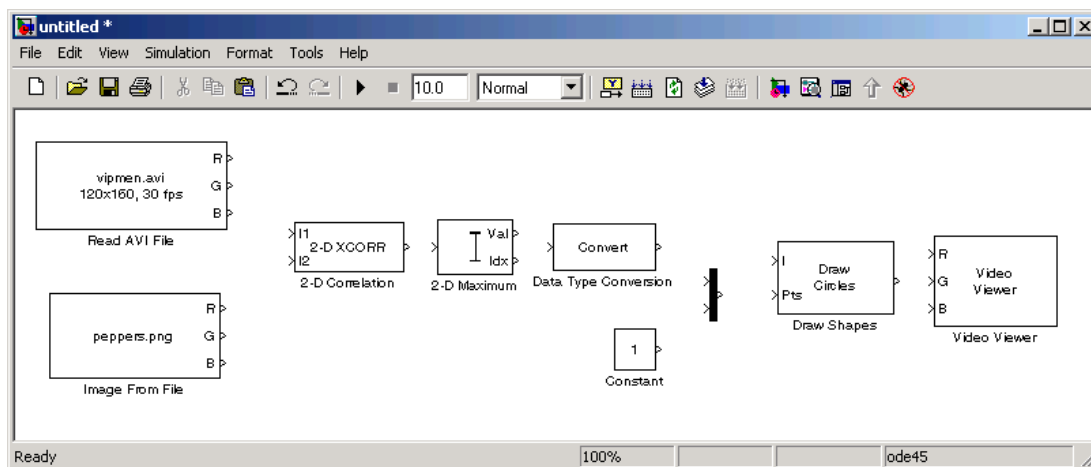

You are now ready to set your block parameters by double-clicking the blocks, modifying the block parameter values, and clicking **OK**.

3 Use the Read AVI File block to import a video into your model. Set the block parameters as follows:

- **File name** = cat\_video.avi
- **Video output data type** = single

4 Use the Image From File block to import the image of the cat sculpture, which is the object you want to track. Set the block parameters as follows:

- **Main** pane, **File name** = cat\_target.png
- **Main** pane, **Output port labels** = I
- **Data Types** pane, **Output data type** = single

- 5 Use the 2-D Correlation block to determine the portion of each video frame that best matches the image of the cat sculpture. Set the block parameters as follows:
  - **Output size** = Valid
  - Select the **Normalized output** check box.

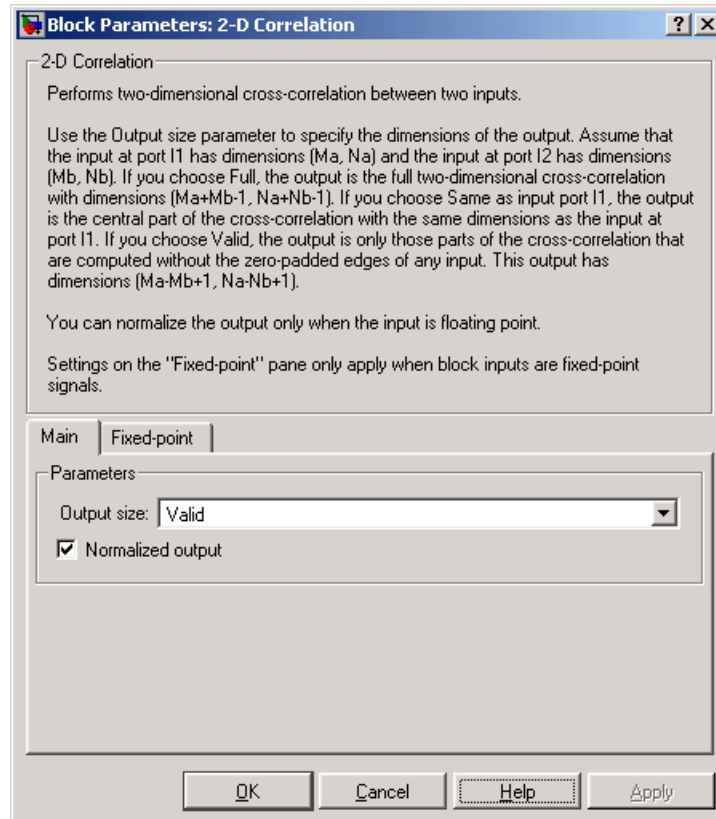

Because you chose Valid for the **Output size** parameter, the block outputs only those parts of the correlation that are computed without the zero-padded edges of any input.

- 6 Use the 2-D Maximum block to find the index of the maximum value in each input matrix. Set the **Mode** parameter to Index.

The block outputs the zero-based location of the maximum value as a two-element vector of 32-bit unsigned integers at the Idx port.

- 7 Use the Data Type Conversion block to change the index values from 32-bit unsigned integers to single-precision floating-point values. Set the **Output data type mode** parameter to single.
- 8 Use the Constant block to define the size of the image of the cat sculpture. Set the **Constant value** parameter to `single([41 41])`.
- 9 Use the Mux block to concatenate the location of the maximum value and the size of the image of the cat sculpture into a single vector. You use this vector to define a rectangular region of interest (ROI) that you will pass to the Draw Shapes block.
- 10 Use the Draw Shapes block to draw a rectangle around the portion of each video frame that best matches the image of the cat sculpture. Set the **Shape** parameter to Rectangles.

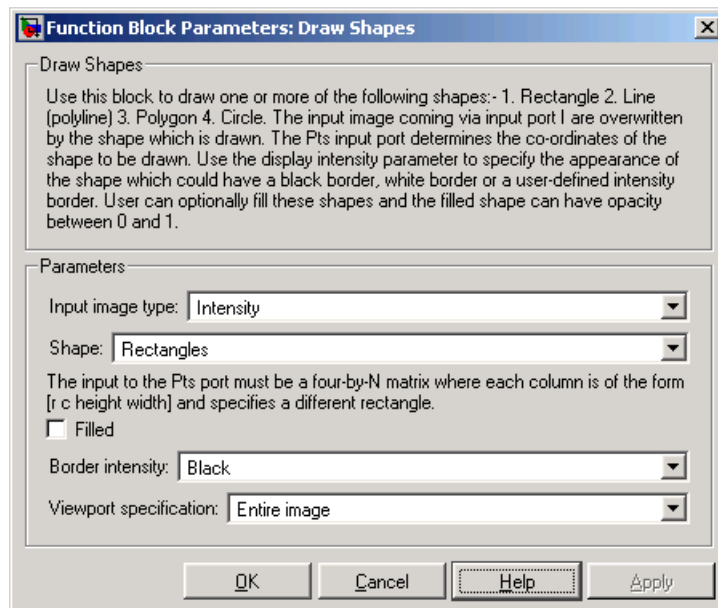

- 11 Use the Video Viewer block to display the video stream with the ROI displayed on it. Set the **Input image type** parameter to Intensity.

The Video Viewer block automatically displays the video in the Video Viewer window when you run the model. Because the image is represented by single-precision floating point values, a value of 0 corresponds to black and a value of 1 corresponds to white.

**12** Connect the blocks as shown below.

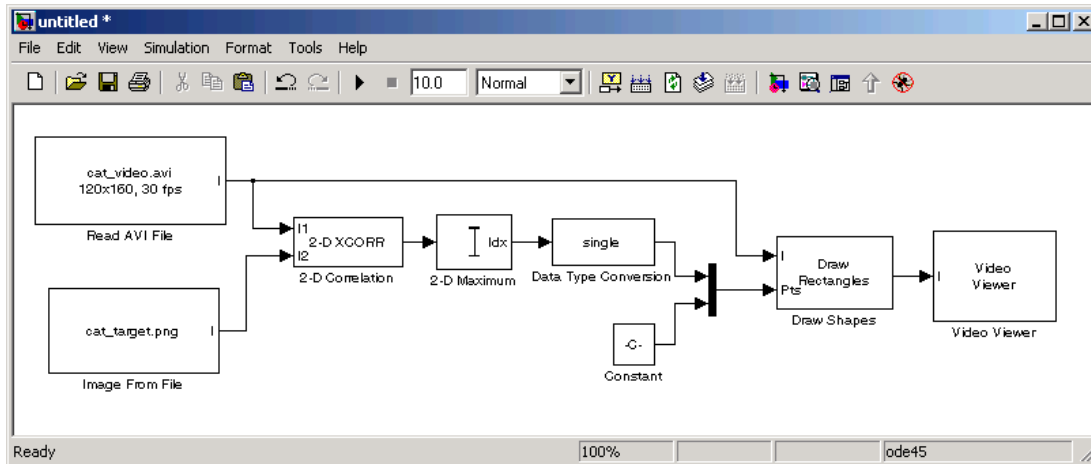

**13** Set the configuration parameters. Open the Configuration dialog box by selecting **Configuration Parameters** from the **Simulation** menu. Set the parameters as follows:

- **Solver** pane, **Stop time** = inf
- **Solver** pane, **Type** = Fixed-step
- **Solver** pane, **Solver** = discrete (no continuous states)

**14** Run the simulation.

The video is displayed in the Video Viewer window and a rectangular box appears around the cat sculpture. To view the video at its true size, right-click the window and select **Set Display To True Size**.



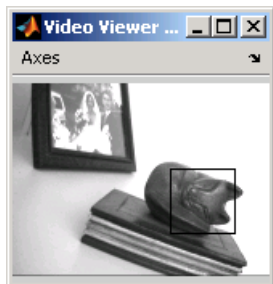

As the video plays, you can watch the rectangular ROI follow the sculpture as it moves.

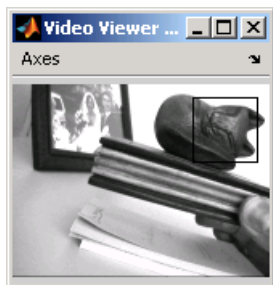

In this example, you used the 2-D Correlation, 2-D Maximum, and Draw Shapes blocks to track the motion of an object in a video stream. For more information about these blocks, see the 2-D Correlation, 2-D Maximum, and Draw Shapes block reference pages.

---

**Note** This example model does not provide an indication of whether or not the sculpture is present in each video frame. For an example of this type of model, type `vippattern` at the MATLAB command prompt.

---

## Motion Compensation

Motion compensation is a set of techniques that take advantage of redundancy in consecutive video frames. These techniques are used in video processing applications such as video compression and video stabilization. For both of these applications, motion compensation is a two-step process of detection and compensation. The detection step results in the specification of a motion vector that relates two consecutive video frames. For video compression, the compensation step involves using the motion vector to predict the current video frame from the previous frame and encoding the prediction residual. For video stabilization, the compensation step involves translating the current frame in the opposite direction of the motion vector to stabilize the video sequence.

The Video and Image Processing Blockset contains a video compression demo model that you can open by typing `vipcodec` at the MATLAB command prompt.

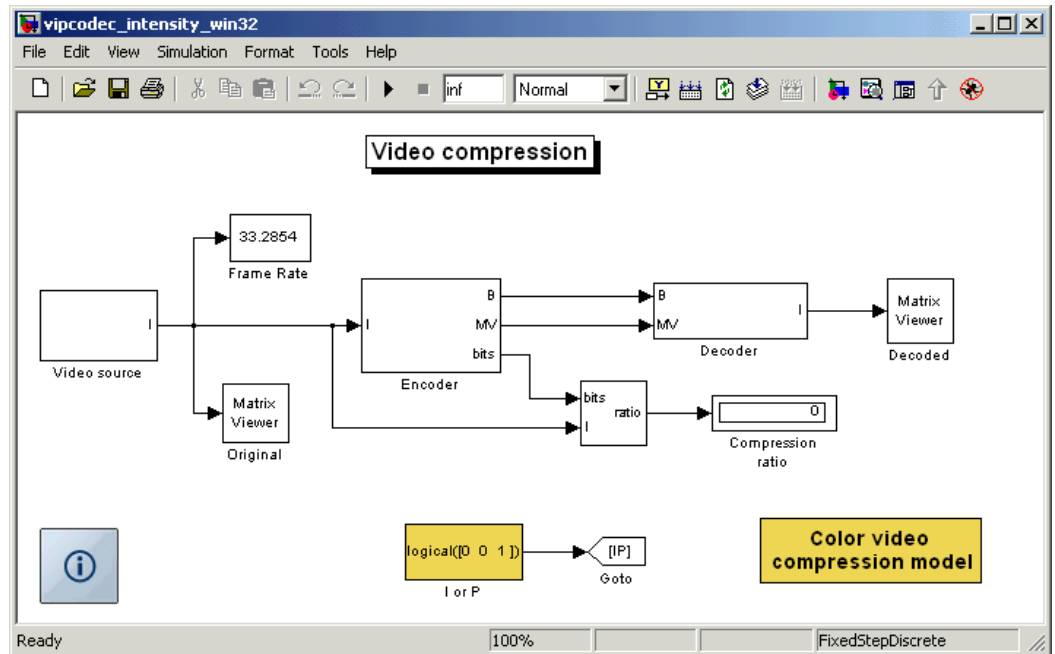

This demo model detects motion by analyzing how much objects move between consecutive video frames. The model aligns two sequential video frames, subtracts them, and codes the residual.

The Video and Image Processing Blockset also contains a video stabilization demo model that you can open by typing `vipstabilize` at the MATLAB command prompt.

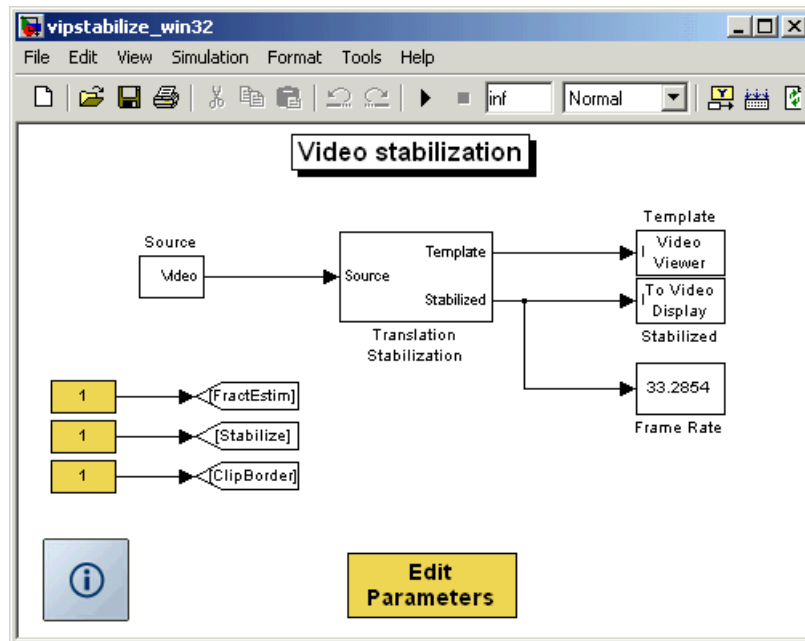

The demo illustrates a motion stabilization technique based on the sum of absolute differences (SAD) method. It applies the SAD technique to remove unwanted translational camera motions and generate a stabilized video.

## Image Compression

The examples in this section illustrate how to build a Simulink model that is capable of image compression. For image compression algorithms, the input image is divided into blocks and the two-dimensional DCT is computed for each block. The DCT coefficients are then quantized, coded, and transmitted. The receiver decodes the quantized DCT coefficients, computes the inverse two-dimensional DCT of each block, and then puts the blocks back together into a single image. Although there is some loss of quality in the reconstructed image, it is recognizable as an approximation of the original image.

This section includes the following topics:

- “Compressing an Image” on page 7-10 – Use the 2-D DCT block to compress a matrix of image coefficients
- “Viewing the Compressed Image” on page 7-17 – Use the 2-D IDCT block to transform the image back to the time domain so it can be viewed

### Compressing an Image

You can use image compression to reduce the size of an image before you transmit it. The compressed image retains many of the original image’s features but requires less bandwidth. In this topic, you use the 2-D DCT and Selector blocks to compress an intensity image:

- 1** Define an intensity image in the MATLAB workspace. To read in an intensity image from a TIF file and convert it to double-precision, at the MATLAB command prompt, type

```
I= imread('cameraman.tif');
```

I is a 256-by-256 matrix of 8-bit unsigned integer values.

- 2** To view the image this matrix represents, at the MATLAB command prompt, type

```
imshow(I)
```

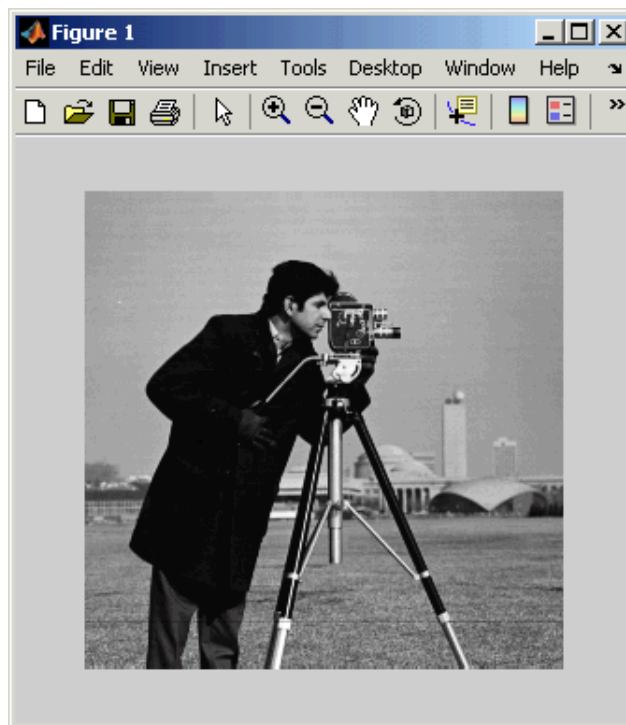
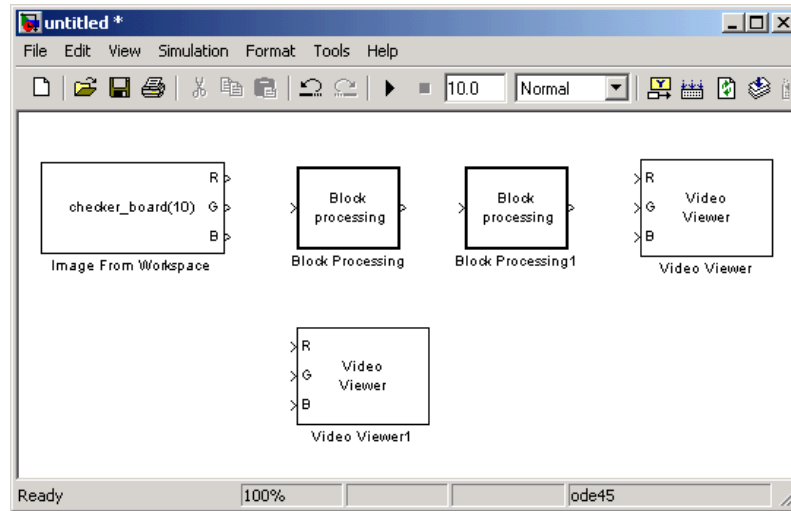

Image Courtesy of MIT

- 3 Create a new Simulink model, and add the following blocks to it.

Block	Library	Quantity
Image From Workspace	Video and Image Processing Blockset / Sources	1
Block Processing	Video and Image Processing Blockset / Utilities	2
Video Viewer	Video and Image Processing Blockset / Sinks	2

- 4 Place the blocks as shown in the figure below.



You are now ready to set your block parameters by double-clicking the blocks, modifying the block parameter values, and clicking **OK**.

- 5 Use the Image From Workspace block to import the intensity image into your model. Set the block parameters as follows:
  - **Main** pane, **Value** = I
  - **Main** pane, **Output port labels** = Image
  - **Data Types** pane, **Output data type** = double
- 6 Use the Video Viewer1 block to view the original intensity image. Set the **Input image type** parameter to Intensity.
- 7 The first Block Processing block represents the transmission portion of the block diagram. This block sends 8-by-8 submatrices of the original matrix to the block's subsystem for processing. Use this block when you want to perform block-based processing on large input images. To view the subsystem, double-click the block and click **Open Subsystem**.

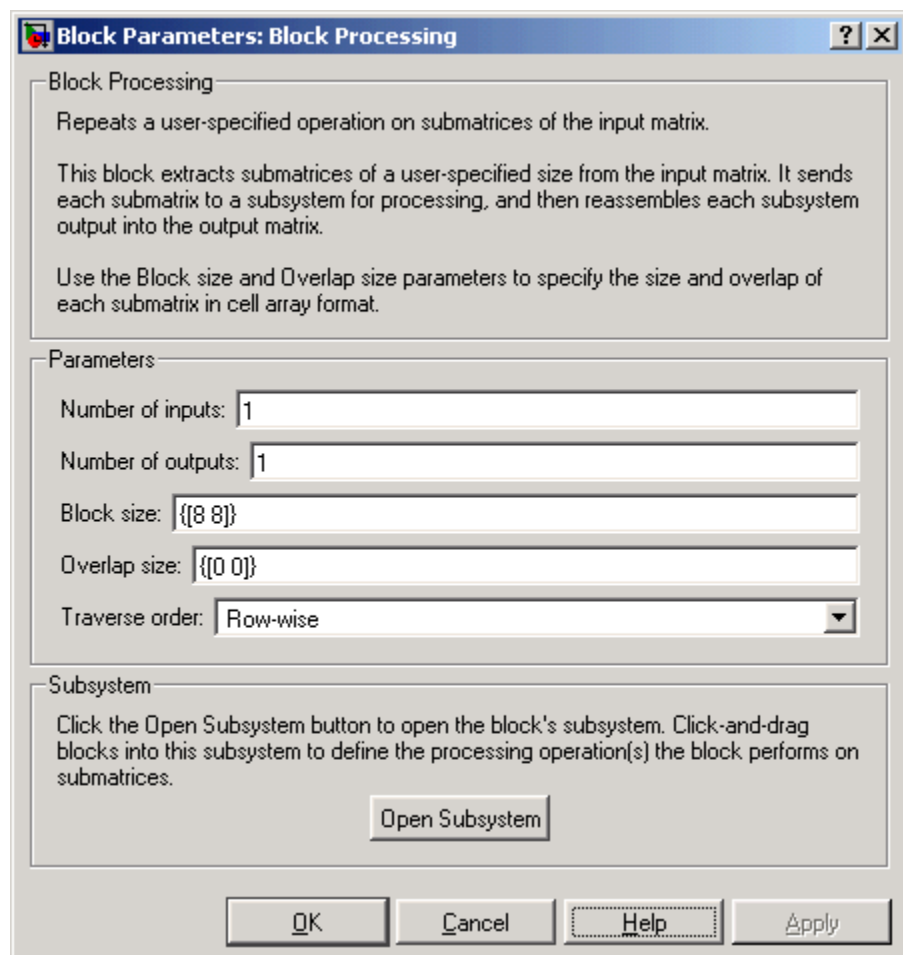

The Block Processing block's subsystem opens.

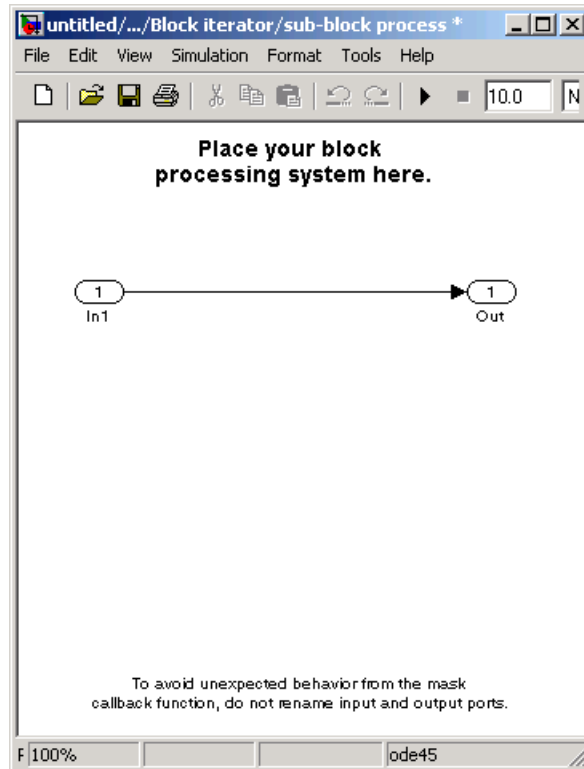

You can drag blocks into this subsystem to process the submatrices.

8 Add the following blocks to your subsystem.

Block	Library	Quantity
2-D DCT	Video and Image Processing Blockset / Transforms	1
Selector	Simulink / Signal Routing	1

9 Connect the blocks as shown in the figure below.



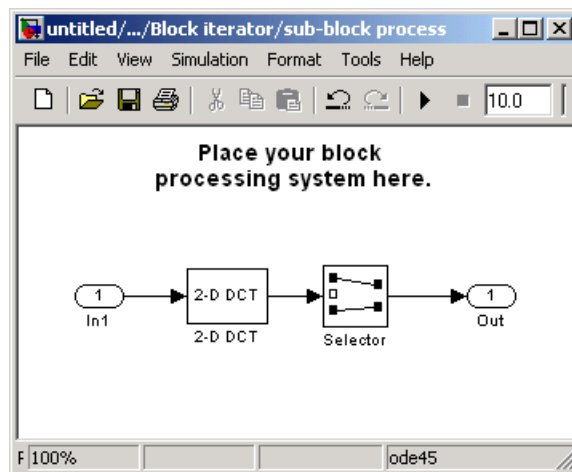

- 10** The 2-D DCT block takes the two-dimensional DCT of each submatrix. This process puts most of the energy in the image into the upper left corner of the resulting matrix. Use the default parameters.
- 11** Use the Selector block to extract the upper left corner of the submatrix. Set the block parameters as follows:
- **Input type** = Matrix
  - **Index mode** = Zero-based
  - **Rows (-1 for all rows)** = 0
  - **Columns (-1 for all columns)** = 0
  - Select the **Use index as starting value** check box.
  - **Output port dimensions** = [ 4 4 ]

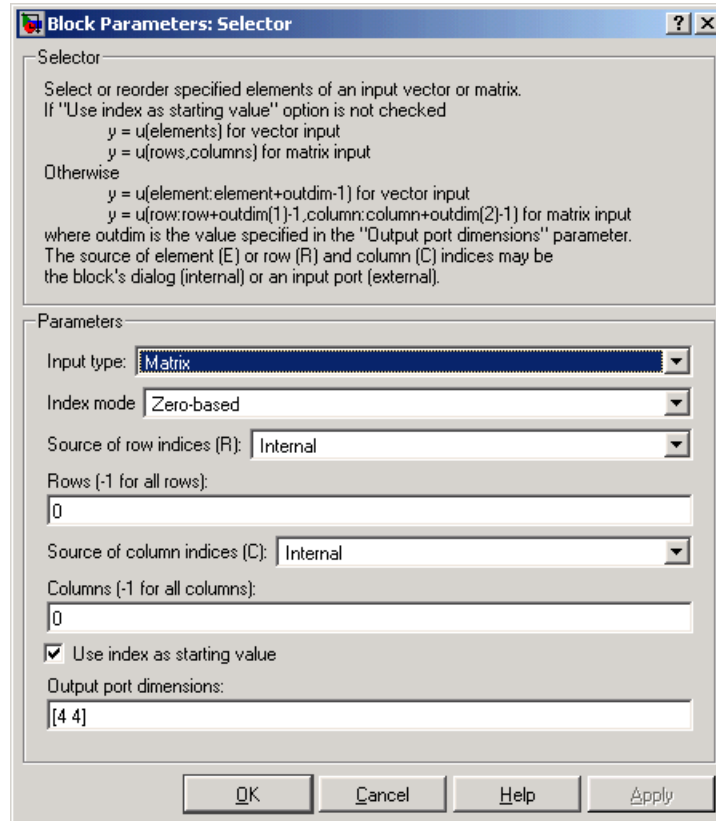

You are using the Selector block to compress the image by extracting the upper left corner of the submatrix, which contains the high energy image coefficients. You want to transmit only this portion of the submatrix because it requires less bandwidth than transmitting the entire submatrix.

**12** Close the subsystem and the Block Processing dialog box.

You have now configured the Block Processing and 2-D DCT blocks to compress an image for transmission. In the next topic, you use the 2-D IDCT block to transform the image back to the time domain. Then, you view the compressed image.

## Viewing the Compressed Image

In the previous topic, you compressed an image using the 2-D DCT and Selector blocks. Now, you can use the 2-D IDCT block to transform the image back to the time domain and view the result:

- 1 If you have not already done so, define an intensity image in the MATLAB workspace by typing

```
I= imread('cameraman.tif');
```

I is a 256-by-256 matrix of 8-bit unsigned integer values.

- 2 If the model you created in “Compressing an Image” on page 7-10 is not open on your desktop, you can open an equivalent model by typing

```
doc_compression
```

at the MATLAB command prompt.

- 3 Use the Block Processing1 block to set the size of the submatrices that the block passes to the subsystem. Set the **Block size** parameter to {[4 4]}.

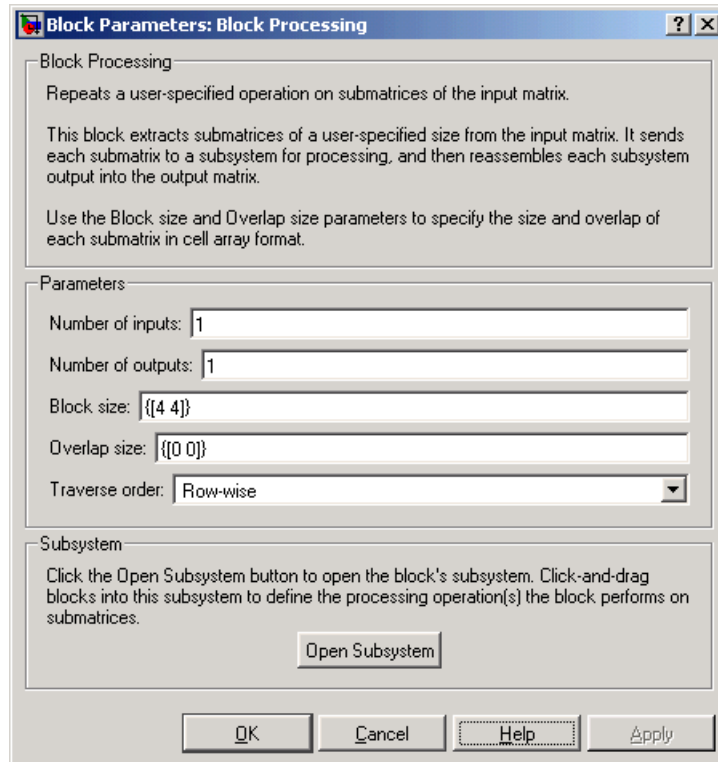

- 4 Open the block's subsystem by clicking **Open Subsystem**, and add the following blocks to it.

Block	Library	Quantity
2-D Pad	Video and Image Processing Blockset / Utilities	1
2-D IDCT	Video and Image Processing Blockset / Transforms	1

- 5 Connect the blocks as shown in the figure below.

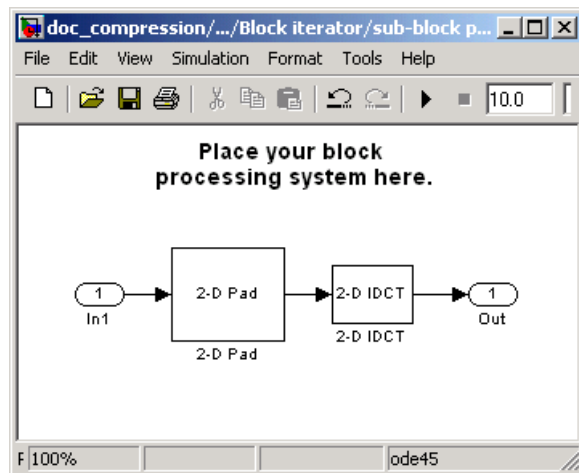

- 6 Use the 2-D Pad block to zero pad the 4-by-4 submatrix back to its original 8-by-8 size. Set the block parameters as follows:
- **Pad rows at** = Right
  - **Pad size along rows** = 4
  - **Pad columns at** = Bottom
  - **Pad size along columns** = 4

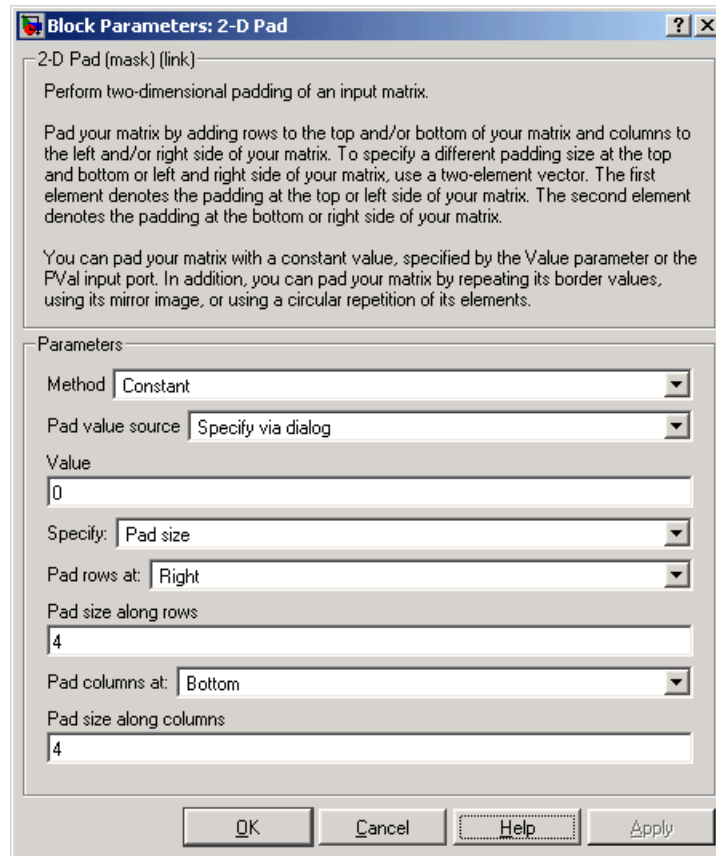

Because zeros are replacing the low energy transform coefficients, the output image is an approximation of the original image.

- 7 The 2-D IDCT block takes the inverse two-dimensional DCT of the submatrices. Use the default parameters.
- 8 Close the subsystem and the Block Processing1 dialog box.
- 9 Use the Video Viewer block to view the compressed image. Set the **Input image type** parameter to Intensity.
- 10 Connect the blocks as shown in the figure below.

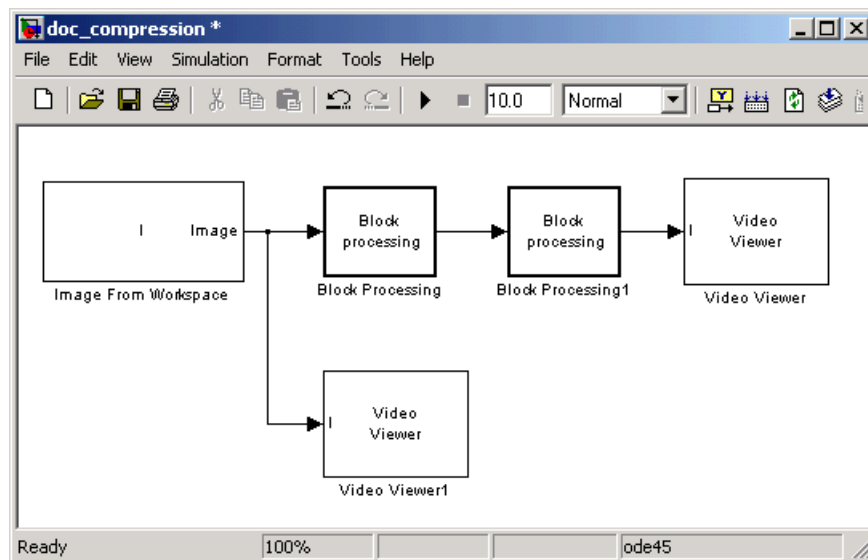

**11** Set the configuration parameters. Open the Configuration dialog box by selecting **Configuration Parameters** from the **Simulation** menu. Set the parameters as follows:

- **Solver** pane, **Stop time** = 0
- **Solver** pane, **Type** = Fixed-step
- **Solver** pane, **Solver** = discrete (no continuous states)

**12** Run the model.

The original image is displayed in the Video Viewer1 window. To view the image at its true size, right-click the window and select **Set Display To True Size**.



The compressed image is displayed in the Video Viewer window. The compressed image is not as clear as the original image. However, it still contains many of its features. The image below is shown at its true size.



In this example, you used the 2-D DCT, 2-D Pad 2-D IDCT, and Block Processing blocks to compress an image. For more information on these blocks, see the 2-D DCT, 2-D Pad, 2-D IDCT, and Block Processing block



reference pages. For information on the Selector block, see the Simulink documentation. For more information on sharpening an image, see “Sharpening and Blurring an Image” on page 6-10.



# Blocks — Categorical List

---

The Video and Image Processing Blockset contains the block libraries described in the following table. Access the libraries by typing `viplib` at the MATLAB command line or using the Simulink Library Browser.

For an alphabetical reference to block reference pages, see Chapter 9, “Blocks — Alphabetical List”.

## Analysis & Enhancement

This library contains blocks that analyze or enhance your image or video stream.

Edge Detection	Find edges of objects in images using the Sobel, Prewitt, or Roberts method
Histogram Equalization	Enhance contrast of images using histogram equalization
Median Filter	Perform two-dimensional median filtering
SAD	Perform two-dimensional sum of absolute differences (SAD)

## Conversions

This library contains blocks that perform conversion operations such as color space conversion.

Autothreshold	Convert intensity image to binary image
Chroma Resampling	Downsample or upsample chrominance components of images
Color Space Conversion	Convert color information between R'G'B' and Y'CbCr and from R'G'B' to intensity
Gamma Correction	Apply or remove gamma correction from images or video streams

Image Complement	Compute the complement of pixel values in binary, intensity, or RGB images
Image Data Type Conversion	Convert and scale input image to specified output data type

## Filtering

This library contains blocks that filter an image or video stream.

2-D Convolution	Compute two-dimensional discrete convolution of two input matrices
2-D FIR Filter	Perform two-dimensional FIR filtering on input matrix
Median Filter	Perform two-dimensional median filtering

## Geometric Transformations

This library contains blocks that manipulate the size, shape, and orientation of an image or video stream.

Resize	Enlarge or shrink size of images
Rotate	Rotate image by specified angle
Shear	Shift each row or column of an image by a linearly varying offset
Translate	Translate image in two-dimensional plane using displacement vector

## Morphological Operations

This library contains blocks that perform morphological operations such as erosion and dilation.

Bottom-hat	Perform bottom-hat filtering on intensity or binary images
Closing	Perform morphological closing on binary or intensity images
Dilation	Find local maxima in binary or intensity images
Erosion	Find local minima in binary or intensity images
Label	Label connected components in binary images
Opening	Perform morphological opening on binary or intensity images
Top-hat	Perform top-hat filtering on intensity or binary images

## Sinks

This library contains blocks that export or display images or video.

Frame Rate Display	Calculate and display frame rate of signals
MPlay	View video from MATLAB workspace, file, or Simulink model
To Multimedia File	Write video frames and/or audio samples to multimedia file

---

To Video Display	Send video data to video output device, video camera, video monitor, or window on your computer screen
Video To Workspace	Export video signal to MATLAB workspace
Video Viewer	Display binary, intensity, or RGB images or video streams
Write AVI File	Write video frames to uncompressed AVI file
Write Binary File	Write binary video data to files

## Sources

This library contains blocks that import images or video into a Simulink model.

From Multimedia File	Read video frames and/or audio samples from compressed multimedia file
Image From File	Import image from image file
Image From Workspace	Import image from MATLAB workspace
Read AVI File	Read uncompressed video frames from AVI file
Read Binary File	Read binary video data from files
Video From Workspace	Import video signal from MATLAB workspace

## Statistics

This library contains blocks that perform statistical operations on an image or video stream.

2-D Autocorrelation	Compute two-dimensional autocorrelation of input matrix
2-D Correlation	Compute two-dimensional cross-correlation of two input matrices
2-D Histogram	Generate histogram of each input matrix
2-D Maximum	Find maximum value in each input matrix
2-D Mean	Find mean value of each input matrix
2-D Median	Find median value of each input matrix
2-D Minimum	Find minimum value of each input matrix
2-D Standard Deviation	Find standard deviation of each input matrix
2-D Variance	Compute variance of each input matrix
Blob Analysis	Compute statistical values for labeled regions
Find Local Maxima	Find local maxima in matrices



## Text & Graphics

This library contains blocks that annotate an image or video stream.

Compositing	Combine pixel values of two images or overlay one image over another
Draw Markers	Mark locations by drawing circles, x-marks, plus signs, stars, or squares
Draw Shapes	Draw rectangles, lines, polygons, or circles on images
Insert Text	Draw text on image or video stream

## Transforms

This library contains blocks to perform transform operations such as 2-D FFT and 2-D DCT.

2-D DCT	Compute two-dimensional discrete cosine transform (DCT)
2-D FFT	Compute two-dimensional FFT of input
2-D IDCT	Compute two-dimensional inverse discrete cosine transform (IDCT)
2-D IFFT	Compute two-dimensional IFFT of input
Hough Lines	Find Cartesian coordinates of lines that are described by rho and theta pairs
Hough Transform	Find lines in images

## Utilities

This library contains blocks that perform processing operations such as 2-D Pad and Block Processing.

2-D Pad

Pad matrix along its rows and/or columns

Block Processing

Repeat user-specified operation on submatrices of input matrix

Variable Selector

Select subset of rows or columns from input

# Blocks — Alphabetical List

---

This section contains an alphabetical list of blocks followed by block reference pages arranged alphabetically.

## 2-D Autocorrelation

**Purpose** Compute two-dimensional autocorrelation of input matrix

**Library** Statistics

### Description



The 2-D Autocorrelation block computes the two-dimensional autocorrelation of the input matrix. Assume that input matrix  $A$  has dimensions  $(Ma, Na)$ . The equation for the two-dimensional discrete autocorrelation is

$$C(i, j) = \sum_{m=0}^{(Ma-1)} \sum_{n=0}^{(Na-1)} A(m, n) \cdot \text{conj}(A(m+i, n+j))$$

where  $0 \leq i < 2Ma - 1$  and  $0 \leq j < 2Na - 1$ .

The output of this block has dimensions  $(2Ma - 1, 2Na - 1)$ .

Port	Input/Output	Supported Data Types	Supports Complex Values?
Input	Scalar, vector, or matrix of intensity values or a scalar, vector, or matrix that represents one plane of the RGB video stream	<ul style="list-style-type: none"> <li>• Double-precision floating point</li> <li>• Single-precision floating point</li> <li>• Fixed point</li> </ul>	Yes
Output	Autocorrelation of the input matrix	Same as Input port	Yes

If the data type of the input is floating point, the output of the block has the same data type. This block supports a signal represented by a Simulink virtual bus.

### Fixed-Point Data Types

The following diagram shows the data types used within the 2-D Autocorrelation block for fixed-point signals.

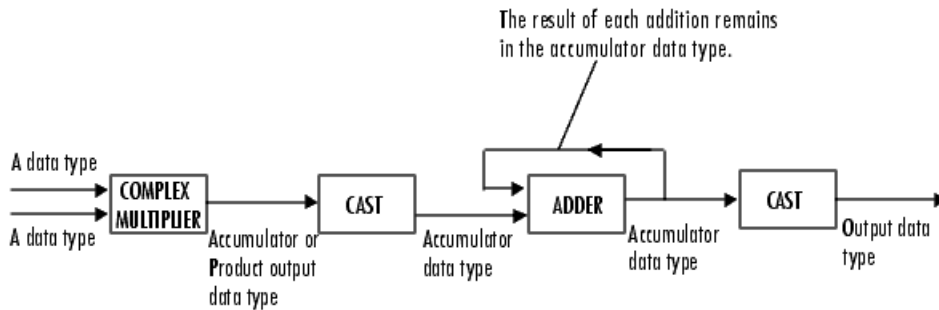

You can set the product output, accumulator, and output data types in the block mask as discussed in "Dialog Box" on page 9-4.

The output of the multiplier is in the product output data type if at least one of the inputs to the multiplier is real. If both of the inputs to the multiplier are complex, the result of the multiplication is in the accumulator data type. For details on the complex multiplication performed, refer to "Multiplication Data Types" in the Signal Processing Blockset documentation.

## 2-D Autocorrelation

---

### Dialog Box

The **Main** pane of the 2-D Autocorrelation block dialog appears as follows:

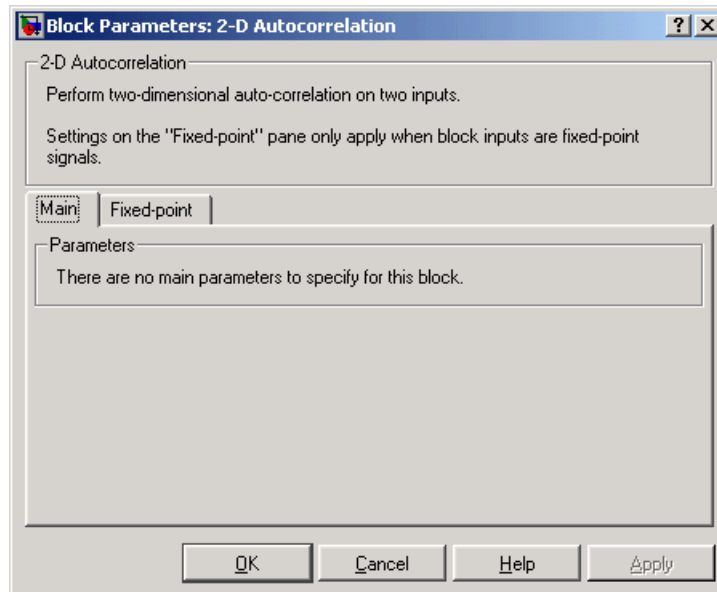

The **Fixed-point** pane of the 2-D Autocorrelation block dialog appears as follows:

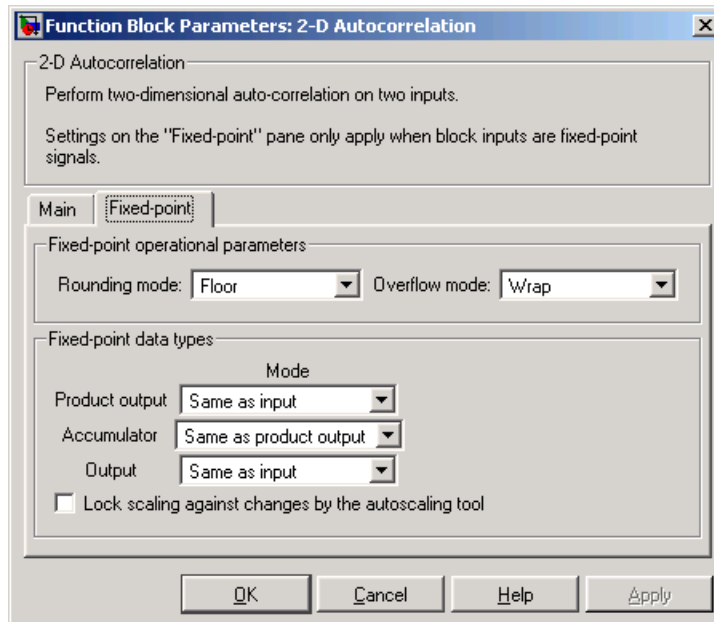

## **Rounding mode**

Select the rounding mode for fixed-point operations.

## **Overflow mode**

Select the overflow mode for fixed-point operations.

## **Product output**

Use this parameter to specify how you would like to designate the product output word and fraction lengths. Refer to "Fixed-Point Data Types" on page 9-2 and "Multiplication Data Types" in the Signal Processing Blockset documentation for illustrations depicting the use of the product output data type in this block:

- When you select Same as input, these characteristics will match those of the input to the block.

## 2-D Autocorrelation

---

- When you select **Binary point scaling**, you can enter the word length and the fraction length of the product output, in bits.
- When you select **Slope and bias scaling**, you can enter the word length, in bits, and the slope of the product output. The bias of all signals in the Signal Processing Blockset is zero.

### **Accumulator**

Use this parameter to specify how you would like to designate the accumulator word and fraction lengths. Refer to “Fixed-Point Data Types” on page 9-2 and “Multiplication Data Types” in the Signal Processing Blockset documentation for illustrations depicting the use of the accumulator data type in this block. Note that the accumulator data type is only used when both inputs to the multiplier are complex:

- When you select **Same as product output**, these characteristics will match those of the product output.
- When you select **Same as input**, these characteristics will match those of the input to the block.
- When you select **Binary point scaling**, you can enter the word length and the fraction length of the accumulator, in bits.
- When you select **Slope and bias scaling**, you can enter the word length, in bits, and the slope of the accumulator. The bias of all signals in the Signal Processing Blockset is zero.

### **Output**

Choose how you will specify the output word length and fraction length.

- When you select **Same as input**, these characteristics will match those of the input to the block.
- When you select **Binary point scaling**, you can enter the word length and the fraction length of the output, in bits.



- When you select Slope and bias scaling, you can enter the word length, in bits, and the slope of the output. The bias of all signals in the Signal Processing Blockset is zero.

### **Lock scaling against changes by the autoscaling tool**

Select this parameter to prevent any fixed-point scaling you specify in this block mask from being overridden by the autoscaling tool in the Fixed-Point Settings interface. For more information about the autoscaling tool, refer to the Fixed-Point Settings Interface section of the Signal Processing Blockset User's Guide.

### **See Also**

2-D Correlation	Video and Image Processing Blockset
2-D Histogram	Video and Image Processing Blockset
2-D Maximum	Video and Image Processing Blockset
2-D Mean	Video and Image Processing Blockset
2-D Median	Video and Image Processing Blockset
2-D Minimum	Video and Image Processing Blockset
2-D Standard Deviation	Video and Image Processing Blockset
2-D Variance	Video and Image Processing Blockset

## 2-D Convolution

**Purpose** Compute two-dimensional discrete convolution of two input matrices

**Library** Filtering

**Description** The 2-D Convolution block computes the two-dimensional convolution of two input matrices. Assume that matrix A has dimensions (Ma, Na) and matrix B has dimensions (Mb, Nb). When the block calculates the full output size, the equation for the 2-D discrete convolution is

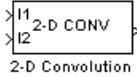

$$C(i, j) = \sum_{m=0}^{(Ma-1)} \sum_{n=0}^{(Na-1)} A(m, n) * B(i - m, j - n)$$

where  $0 \leq i < Ma + Mb - 1$  and  $0 \leq j < Na + Nb - 1$ .

Port	Input/Output	Supported Data Types	Supports Complex Values?
I1	Matrix of intensity values or a matrix that represents one plane of the RGB video stream	<ul style="list-style-type: none"> <li>• Double-precision floating point</li> <li>• Single-precision floating point</li> <li>• Fixed point</li> </ul>	Yes
I2	Matrix of intensity values or a matrix that represents one plane of the RGB video stream	Same as I1 port	Yes
Output	Convolution of the input matrices	Same as I1 port	Yes

If the data type of the input is floating point, the output of the block has the same data type. This block supports a signal represented by a Simulink virtual bus.

The dimensions of the output are dictated by the **Output size** parameter. Assume that the input at port I1 has dimensions (Ma, Na) and the input at port I2 has dimensions (Mb, Nb). If, for the **Output**

**size** parameter, you choose **Full**, the output is the full two-dimensional convolution with dimensions  $(M_a+M_b-1, N_a+N_b-1)$ . If, for the **Output size** parameter, you choose **Same** as input port **I1**, the output is the central part of the convolution with the same dimensions as the input at port **I1**. If, for the **Output size** parameter, you choose **Valid**, the output is only those parts of the convolution that are computed without the zero-padded edges of any input. This output has dimensions  $(M_a-M_b+1, N_a-N_b+1)$ . However, if  $\text{all}(\text{size}(I1) < \text{size}(I2))$ , the block errors out.

If you select the **Output normalized convolution** check box, the block's output is divided by  $\sqrt{\text{sum}(\text{dot}(I1p, I1p)) * \text{sum}(\text{dot}(I2, I2))}$ , where **I1p** is the portion of the **I1** matrix that aligns with the **I2** matrix. See “Example 2” on page 9-12 for more information.

---

**Note** When you select the **Output normalized convolution** check box, the block input cannot be fixed point.

---

## Fixed-Point Data Types

The following diagram shows the data types used within the 2-D Convolution block for fixed-point signals.

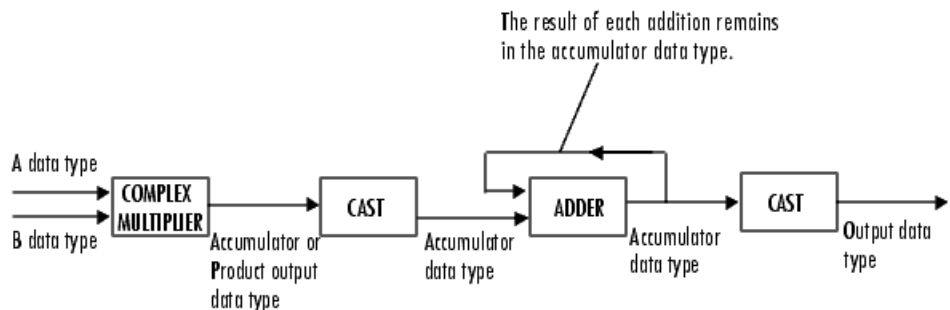

## 2-D Convolution

---

You can set the product output, accumulator, and output data types in the block mask as discussed in “Dialog Box” on page 9-15.

The output of the multiplier is in the product output data type if at least one of the inputs to the multiplier is real. If both of the inputs to the multiplier are complex, the result of the multiplication is in the accumulator data type. For details on the complex multiplication performed, refer to "Multiplication Data Types" in the Signal Processing Blockset documentation.

### Examples

#### Example 1

Suppose  $I1$ , the first input matrix, has dimensions (4,3) and  $I2$ , the second input matrix, has dimensions (2,2). If, for the **Output size** parameter, you choose **Full**, the block uses the following equations to determine the number of rows and columns of the output matrix:

$$C_{\text{full\_rows}} = I1_{\text{rows}} + I2_{\text{rows}} - 1 = 5$$

$$C_{\text{full\_columns}} = I1_{\text{columns}} + I2_{\text{columns}} - 1 = 4$$

The resulting matrix is

$$C_{\text{full}} = \begin{bmatrix} c_{00} & c_{01} & c_{02} & c_{03} \\ c_{10} & c_{11} & c_{12} & c_{13} \\ c_{20} & c_{21} & c_{22} & c_{23} \\ c_{30} & c_{31} & c_{32} & c_{33} \\ c_{40} & c_{41} & c_{42} & c_{43} \end{bmatrix}$$

If, for the **Output size** parameter, you choose **Same** as input port  $I1$ , the output is the central part of  $C_{\text{full}}$  with the same dimensions as

the input at port I1, (4,3). However, since a 4-by-3 matrix cannot be extracted from the exact center of  $C_{full}$ , the block leaves more rows and columns on the top and left side of the  $C_{full}$  matrix and outputs:

$$C_{\text{same}} = \begin{bmatrix} c_{11} & c_{12} & c_{13} \\ c_{21} & c_{22} & c_{23} \\ c_{31} & c_{32} & c_{33} \\ c_{41} & c_{42} & c_{43} \end{bmatrix}$$

If, for the **Output size** parameter, you choose Valid, the block uses the following equations to determine the number of rows and columns of the output matrix:

$$C_{\text{valid}_{\text{rows}}} = I1_{\text{rows}} - I2_{\text{rows}} + 1 = 3$$

$$C_{\text{valid}_{\text{columns}}} = I1_{\text{columns}} - I2_{\text{columns}} + 1 = 2$$

In this case, it is always possible to extract the exact center of  $C_{full}$ . Therefore, the block outputs

## 2-D Convolution

---

$$C_{\text{full}} = \begin{bmatrix} c_{11} & c_{12} \\ c_{21} & c_{22} \\ c_{31} & c_{32} \end{bmatrix}$$

### Example 2

In convolution, the value of an output element is computed as a weighted sum of neighboring elements.

For example, suppose the first input matrix represents an image and is defined as

$$I1 = \begin{bmatrix} 17 & 24 & 1 & 8 & 15 \\ 23 & 5 & 7 & 14 & 16 \\ 4 & 6 & 13 & 20 & 22 \\ 10 & 12 & 19 & 21 & 3 \\ 11 & 18 & 25 & 2 & 9 \end{bmatrix}$$

The second input matrix also represents an image and is defined as

$$I2 = \begin{bmatrix} 8 & 1 & 6 \\ 3 & 5 & 7 \\ 4 & 9 & 2 \end{bmatrix}$$

The following figure shows how to compute the (1,1) output element (zero-based indexing) using these steps:

- 1 Rotate the second input matrix, I2, 180 degrees about its center element.
- 2 Slide the center element of I2 so that it lies on top of the (0,0) element of I1.

- 3** Multiply each element of the rotated I2 matrix by the element of I1 underneath.
- 4** Sum the individual products from step 3.

Hence the (1,1) output element is

$$0 \cdot 2 + 0 \cdot 9 + 0 \cdot 4 + 0 \cdot 7 + 17 \cdot 5 + 24 \cdot 3 + 0 \cdot 6 + 23 \cdot 1 + 5 \cdot 8 = 220$$

# 2-D Convolution

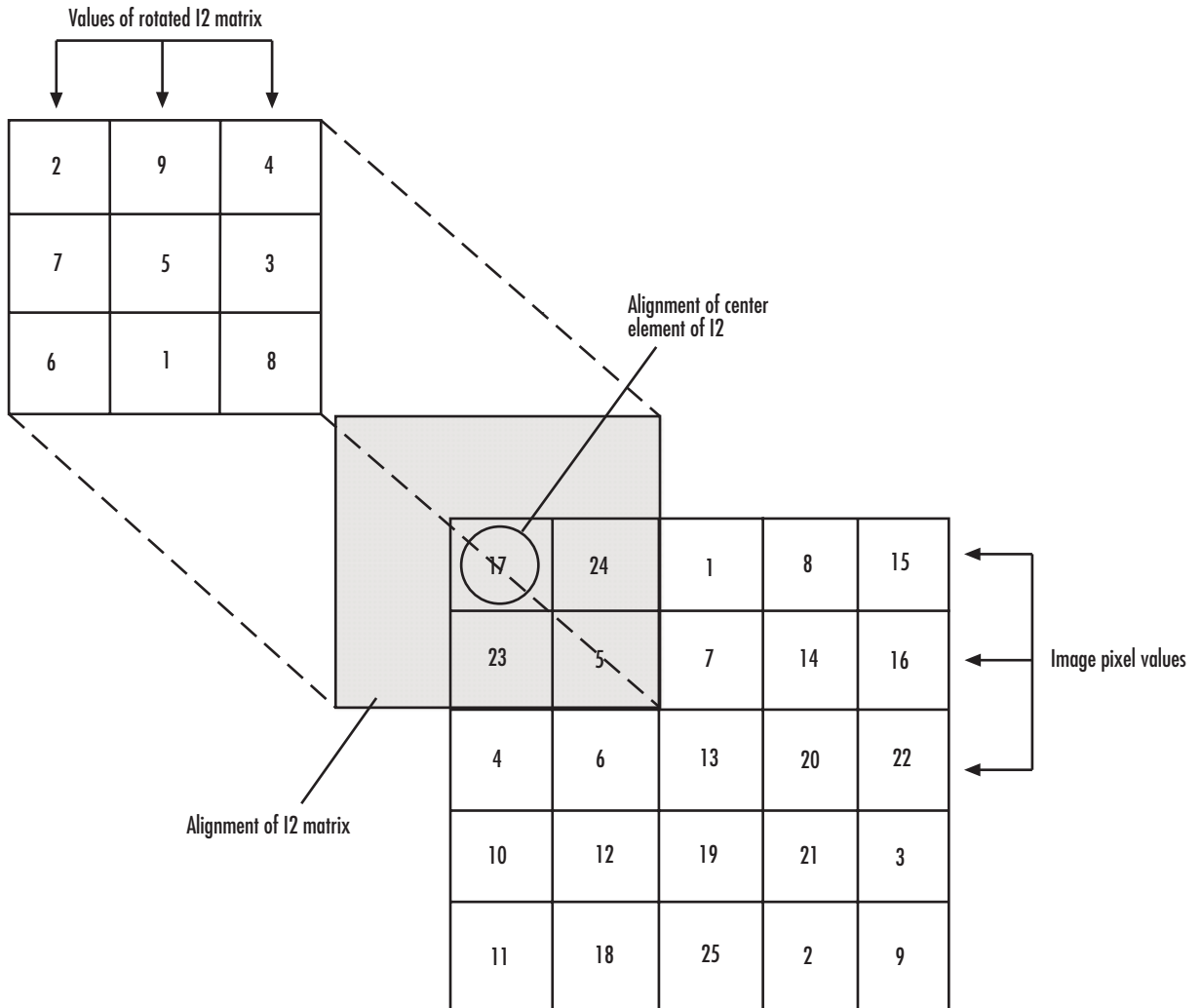

## Computing the (1,1) Output of Convolution

The normalized convolution of the (1,1) output element is  $220/\sqrt{(\text{sum}(\text{dot}(I1p, I1p)) * \text{sum}(\text{dot}(I2, I2)))} = 0.3459$ , where  $I1p = [0 \ 0 \ 0; 0 \ 17 \ 24; 0 \ 23 \ 5]$ .



## Dialog Box

The **Main** pane of the 2-D Convolution block dialog appears as follows:

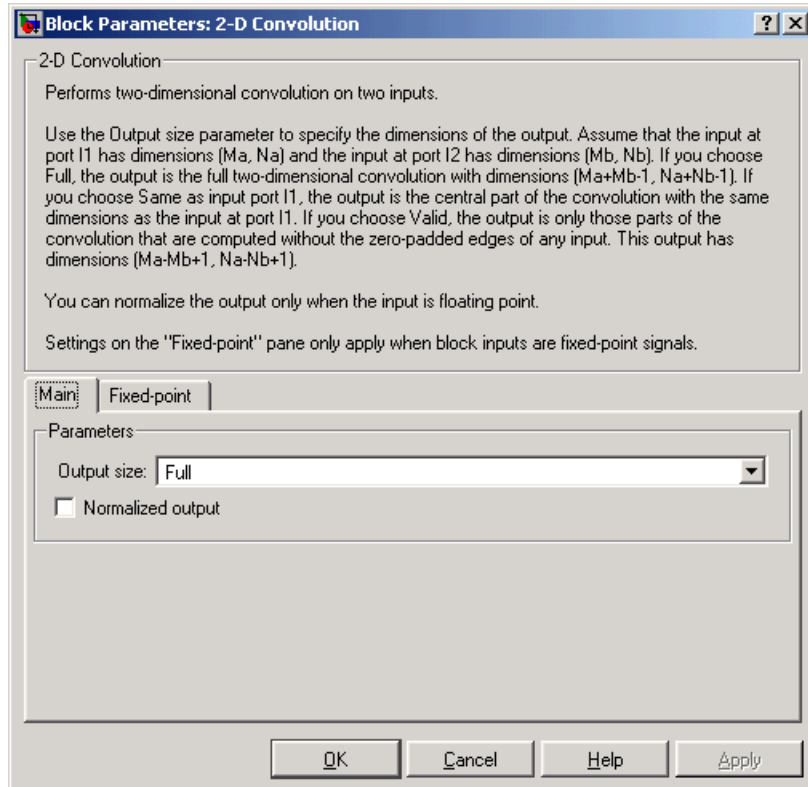

### Output size

This parameter controls the size of the output scalar, vector, or matrix produced as a result of the convolution between the two inputs. If you choose Full, the output has dimensions (Ma+Mb-1, Na+Nb-1). If you choose Same as input port I1, the output has the same dimensions as the input at port I1. If you choose Valid, output has dimensions (Ma-Mb+1, Na-Nb+1).

### Output normalized convolution

If you select this check box, the block's output is normalized.

## 2-D Convolution

The **Fixed-point** pane of the 2-D Convolution block dialog appears as follows:

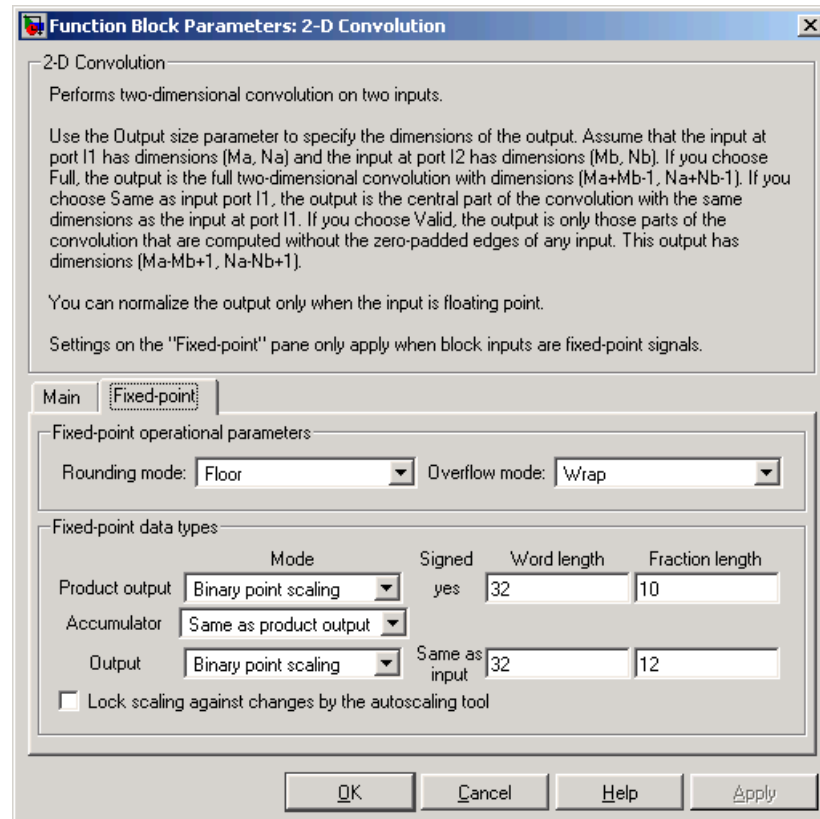

### **Rounding mode**

Select the rounding mode for fixed-point operations.

### **Overflow mode**

Select the overflow mode for fixed-point operations.

### Product output

Use this parameter to specify how you would like to designate the product output word and fraction lengths. Refer to “Fixed-Point Data Types” on page 9-9 and “Multiplication Data Types” in the Signal Processing Blockset documentation for illustrations depicting the use of the product output data type in this block:

- When you select `Same` as first input, these characteristics will match those of the first input to the block.
- When you select `Binary point scaling`, you can enter the word length and the fraction length of the product output, in bits.
- When you select `Slope and bias scaling`, you can enter the word length, in bits, and the slope of the product output. The bias of all signals in the Signal Processing Blockset is zero.

### Accumulator

Use this parameter to specify how you would like to designate the accumulator word and fraction lengths. Refer to “Fixed-Point Data Types” on page 9-9 and “Multiplication Data Types” in the Signal Processing Blockset documentation for illustrations depicting the use of the accumulator data type in this block. Note that the accumulator data type is only used when both inputs to the multiplier are complex:

- When you select `Same` as product output, these characteristics will match those of the product output.
- When you select `Same` as first input, these characteristics will match those of the first input to the block.
- When you select `Binary point scaling`, you can enter the word length and the fraction length of the accumulator, in bits.
- When you select `Slope and bias scaling`, you can enter the word length, in bits, and the slope of the accumulator. The bias of all signals in the Signal Processing Blockset is zero.

## 2-D Convolution

---

### Output

Choose how you will specify the word length and fraction length of the output of the block:

- When you select `Same as first input`, these characteristics will match those of the first input to the block.
- When you select `Binary point scaling`, you can enter the word length and the fraction length of the output, in bits.
- When you select `Slope and bias scaling`, you can enter the word length, in bits, and the slope of the output. The bias of all signals in the Signal Processing Blockset is zero.

### Lock scaling against changes by the autoscaling tool

Select this parameter to prevent any fixed-point scaling you specify in this block mask from being overridden by the autoscaling tool in the Fixed-Point Settings interface. For more information about the autoscaling tool, refer to the Fixed-Point Settings Interface section of the Signal Processing Blockset User's Guide.

### See Also

2-D FIR Filter

Video and Image Processing Blockset

**Purpose** Compute two-dimensional cross-correlation of two input matrices

**Library** Statistics

**Description**

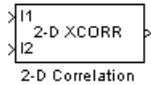

The 2-D Correlation block computes the two-dimensional cross-correlation of two input matrices. Assume that matrix A has dimensions (Ma, Na) and matrix B has dimensions (Mb, Nb). When the block calculates the full output size, the equation for the two-dimensional discrete cross-correlation is

$$C(i, j) = \sum_{m=0}^{(Ma-1)} \sum_{n=0}^{(Na-1)} A(m, n) \cdot \text{conj}(B(m + i, n + j))$$

where  $0 \leq i < Ma + Mb - 1$  and  $0 \leq j < Na + Nb - 1$ .

Port	Input/Output	Supported Data Types	Supports Complex Values?
I1	Scalar, vector, or matrix of intensity values or a scalar, vector, or matrix that represents one plane of the RGB video stream	<ul style="list-style-type: none"> <li>• Double-precision floating point</li> <li>• Single-precision floating point</li> <li>• Fixed point</li> </ul>	Yes
I2	Scalar, vector, or matrix of intensity values or a scalar, vector, or matrix that represents one plane of the RGB video stream	Same as I1 port	Yes
Output	Convolution of the input matrices	Same as I1 port	Yes

If the data type of the input is floating point, the output of the block is the same data type. This block supports a signal represented by a Simulink virtual bus.

## 2-D Correlation

---

The dimensions of the output are dictated by the **Output size** parameter and the sizes of the inputs at ports I1 and I2. For example, assume that the input at port I1 has dimensions (Ma, Na) and the input at port I2 has dimensions (Mb, Nb). If, for the **Output size** parameter, you choose `Full`, the output is the full two-dimensional cross-correlation with dimensions (Ma+Mb-1, Na+Nb-1). If, for the **Output size** parameter, you choose `Same as input port I1`, the output is the central part of the cross-correlation with the same dimensions as the input at port I1. If, for the **Output size** parameter, you choose `Valid`, the output is only those parts of the cross-correlation that are computed without the zero-padded edges of any input. This output has dimensions (Ma-Mb+1, Na-Nb+1). However, if `all(size(I1) < size(I2))`, the block errors out.

If you select the **Normalized output** check box, the block's output is divided by  $\sqrt{\text{sum}(\text{dot}(I1p, I1p)) * \text{sum}(\text{dot}(I2, I2))}$ , where `I1p` is the portion of the I1 matrix that aligns with the I2 matrix. See "Example2" on page 9-23 for more information.

---

**Note** When you select the **Normalized output** check box, the block input cannot be fixed point.

---

### Fixed-Point Data Types

The following diagram shows the data types used within the 2-D Correlation block for fixed-point signals.

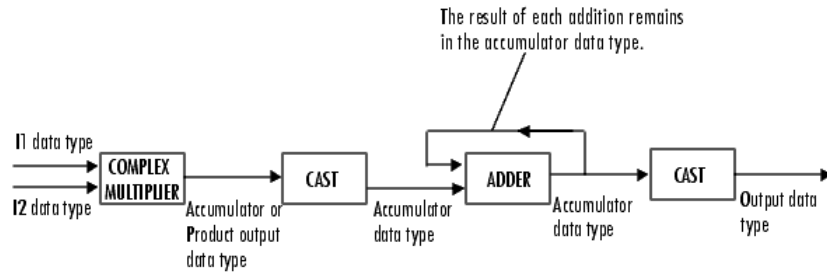

You can set the product output, accumulator, and output data types in the block mask as discussed in “Dialog Box” on page 9-26.

The output of the multiplier is in the product output data type if at least one of the inputs to the multiplier is real. If both of the inputs to the multiplier are complex, the result of the multiplication is in the accumulator data type. For details on the complex multiplication performed, refer to "Multiplication Data Types" in the Signal Processing Blockset documentation.

## Examples

### Example 1

Suppose  $I1$ , the first input matrix, has dimensions (4,3).  $I2$ , the second input matrix, has dimensions (2,2). If, for the **Output size** parameter, you choose **Full**, the block uses the following equations to determine the number of rows and columns of the output matrix:

$$C_{\text{full}_{\text{rows}}} = I1_{\text{rows}} + I2_{\text{rows}} - 1 = 4 + 2 - 1 = 5$$

$$C_{\text{full}_{\text{columns}}} = I1_{\text{columns}} + I2_{\text{columns}} - 1 = 3 + 2 - 1 = 4$$

The resulting matrix is

## 2-D Correlation

---

$$C_{\text{full}} = \begin{bmatrix} c_{00} & c_{01} & c_{02} & c_{03} \\ c_{10} & c_{11} & c_{12} & c_{13} \\ c_{20} & c_{21} & c_{22} & c_{23} \\ c_{30} & c_{31} & c_{32} & c_{33} \\ c_{40} & c_{41} & c_{42} & c_{43} \end{bmatrix}$$

If, for the **Output size** parameter, you choose Same as input port I1, the output is the central part of  $C_{\text{full}}$  with the same dimensions as the input at port I1, (4,3). However, since a 4-by-3 matrix cannot be extracted from the exact center of  $C_{\text{full}}$ , the block leaves more rows and columns on the top and left side of the  $C_{\text{full}}$  matrix and outputs:

$$C_{\text{same}} = \begin{bmatrix} c_{11} & c_{12} & c_{13} \\ c_{21} & c_{22} & c_{23} \\ c_{31} & c_{32} & c_{33} \\ c_{41} & c_{42} & c_{43} \end{bmatrix}$$

If, for the **Output size** parameter, you choose Valid, the block uses the following equations to determine the number of rows and columns of the output matrix:

$$C_{\text{valid}_{\text{rows}}} = I1_{\text{rows}} - I2_{\text{rows}} + 1 = 3$$

$$C_{\text{valid}_{\text{columns}}} = I1_{\text{columns}} - I2_{\text{columns}} + 1 = 2$$



In this case, it is always possible to extract the exact center of  $C_{full}$ . Therefore, the block outputs

$$C_{full} = \begin{bmatrix} c_{11} & c_{12} \\ c_{21} & c_{22} \\ c_{31} & c_{32} \end{bmatrix}$$

### Example2

In cross-correlation, the value of an output element is computed as a weighted sum of neighboring elements.

For example, suppose the first input matrix represents an image and is defined as

$$I1 = \begin{bmatrix} 17 & 24 & 1 & 8 & 15 \\ 23 & 5 & 7 & 14 & 16 \\ 4 & 6 & 13 & 20 & 22 \\ 10 & 12 & 19 & 21 & 3 \\ 11 & 18 & 25 & 2 & 9 \end{bmatrix}$$

The second input matrix also represents an image and is defined as

$$I2 = \begin{bmatrix} 8 & 1 & 6 \\ 3 & 5 & 7 \\ 4 & 9 & 2 \end{bmatrix}$$

The following figure shows how to compute the (2,4) output element (zero-based indexing) using these steps:

- 1 Slide the center element of I2 so that lies on top of the (1,3) element of I1.

## 2-D Correlation

---

**2** Multiply each weight in I2 by the element of I1 underneath.

**3** Sum the individual products from step 2.

The (2,4) output element from the cross-correlation is

$$1 \cdot 8 + 8 \cdot 1 + 15 \cdot 6 - 7 \cdot 3 + 14 \cdot 5 + 16 \cdot 7 - 13 \cdot 4 + 20 \cdot 9 + 22 \cdot 2 = 585.$$

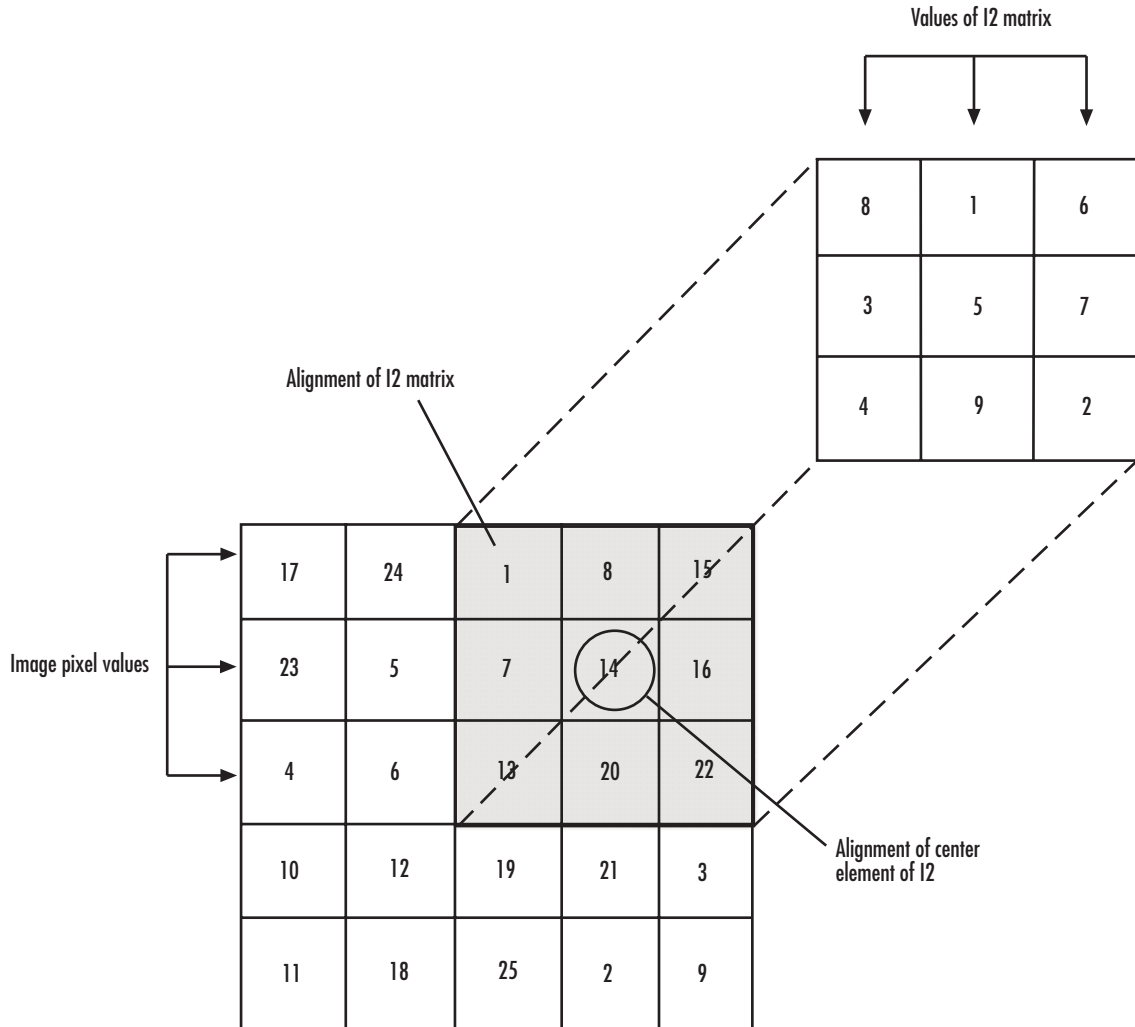

## Computing the (2,4) Output of Cross-Correlation

The normalized cross-correlation of the (2,4) output element is  $585/\sqrt{(\text{sum}(\text{dot}(I1p, I1p)) * \text{sum}(\text{dot}(I2, I2)))} = 0.8070$ , where  $I1p = [1 \ 8 \ 15; 7 \ 14 \ 16; 13 \ 20 \ 22]$ .

# 2-D Correlation

## Dialog Box

The **Main** pane of the 2-D Correlation block dialog appears as follows:

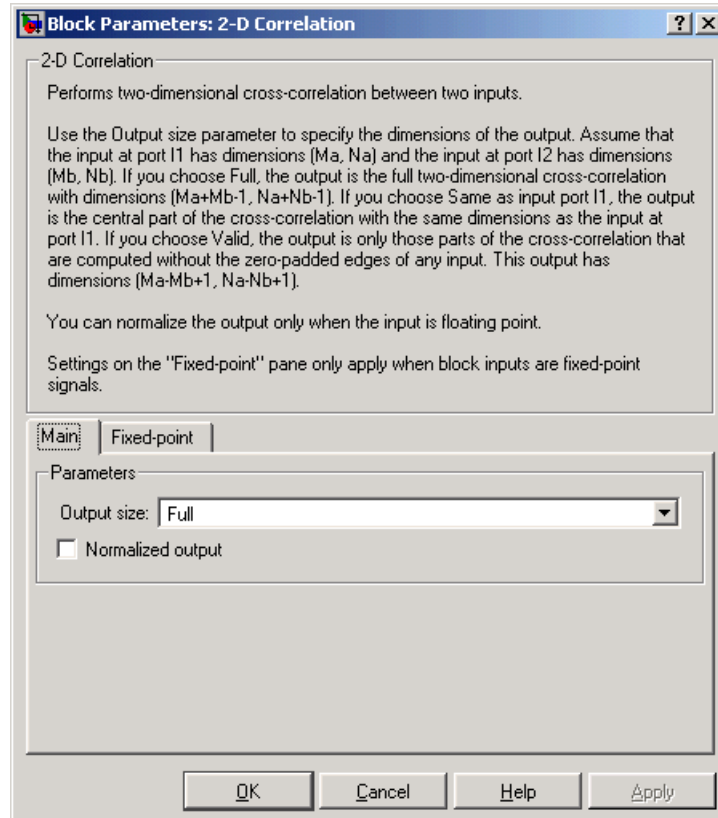

### Output size

This parameter controls the size of the output scalar, vector, or matrix produced as a result of the cross-correlation between the two inputs. If you choose **Full**, the output has dimensions  $(M_a+M_b-1, N_a+N_b-1)$ . If you choose **Same as input port I1**, the output has the same dimensions as the input at port I1. If you choose **Valid**, output has dimensions  $(M_a-M_b+1, N_a-N_b+1)$ .

## Normalized output

If you select this check box, the block's output is normalized.

The **Fixed-point** pane of the 2-D Correlation block dialog appears as follows:

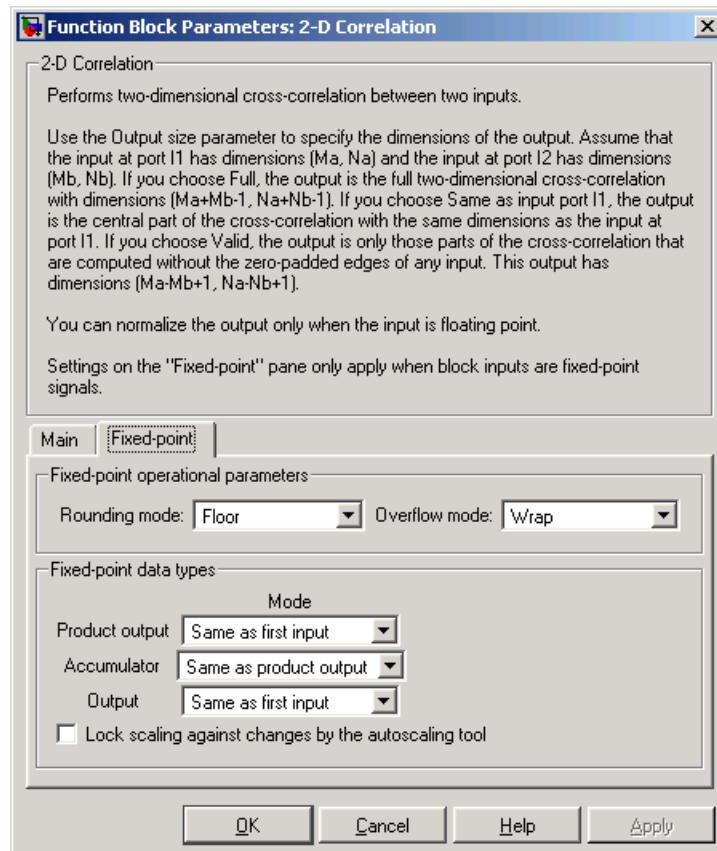

## Rounding mode

Select the rounding mode for fixed-point operations.

## 2-D Correlation

---

### **Overflow mode**

Select the overflow mode for fixed-point operations.

### **Product output**

Use this parameter to specify how you would like to designate the product output word and fraction lengths. Refer to “Fixed-Point Data Types” on page 9-20 and "Multiplication Data Types" in the Signal Processing Blockset documentation for illustrations depicting the use of the product output data type in this block:

- When you select `Same as first input`, these characteristics will match those of the first input to the block.
- When you select `Binary point scaling`, you can enter the word length and the fraction length of the product output, in bits.
- When you select `Slope and bias scaling`, you can enter the word length, in bits, and the slope of the product output. The bias of all signals in the Signal Processing Blockset is zero.

### **Accumulator**

Use this parameter to specify how you would like to designate the accumulator word and fraction lengths. Refer to “Fixed-Point Data Types” on page 9-20 and "Multiplication Data Types" in the Signal Processing Blockset documentation for illustrations depicting the use of the accumulator data type in this block. Note that the accumulator data type is only used when both inputs to the multiplier are complex:

- When you select `Same as product output`, these characteristics will match those of the product output.
- When you select `Same as first input`, these characteristics will match those of the first input to the block.
- When you select `Binary point scaling`, you can enter the word length and the fraction length of the accumulator, in bits.

- When you select **Slope and bias scaling**, you can enter the word length, in bits, and the slope of the accumulator. The bias of all signals in the Signal Processing Blockset is zero.

### Output

Choose how you will specify the word length and fraction length of the output of the block:

- When you select **Same as first input**, these characteristics will match those of the first input to the block.
- When you select **Binary point scaling**, you can enter the word length and the fraction length of the output, in bits.
- When you select **Slope and bias scaling**, you can enter the word length, in bits, and the slope of the output. The bias of all signals in the Signal Processing Blockset is zero.

### Lock scaling against changes by the autoscaling tool

Select this parameter to prevent any fixed-point scaling you specify in this block mask from being overridden by the autoscaling tool in the Fixed-Point Settings interface. For more information about the autoscaling tool, refer to the Fixed-Point Settings Interface section of the Signal Processing Blockset User's Guide.

## See Also

2-D Autocorrelation	Video and Image Processing Blockset
2-D Histogram	Video and Image Processing Blockset
2-D Maximum	Video and Image Processing Blockset
2-D Mean	Video and Image Processing Blockset
2-D Median	Video and Image Processing Blockset
2-D Minimum	Video and Image Processing Blockset
2-D Standard Deviation	Video and Image Processing Blockset
2-D Variance	Video and Image Processing Blockset

## 2-D DCT

**Purpose** Compute two-dimensional discrete cosine transform (DCT)

**Library** Transforms

**Description** The 2-D DCT block calculates the two-dimensional discrete cosine transform of the input signal. The equation for the two-dimensional DCT is



$$F(m,n) = \frac{2}{\sqrt{MN}} C(m)C(n) \sum_{x=0}^{M-1} \sum_{y=0}^{N-1} f(x,y) \cos \frac{(2x+1)m\pi}{2M} \cos \frac{(2y+1)n\pi}{2N}$$

where  $C(m), C(n) = 1/\sqrt{2}$  for  $m, n = 0$  and  $C(m), C(n) = 1$  otherwise.

The number of rows and columns of the input signal must be powers of two. The output of this block has dimensions the same dimensions as the input.

Port	Input/Output	Supported Data Types	Supports Complex Values?
Input	Scalar, vector, or matrix of intensity values or a scalar, vector, or matrix that represents one plane of the RGB video stream	<ul style="list-style-type: none"> <li>• Double-precision floating point</li> <li>• Single-precision floating point</li> <li>• Fixed point</li> </ul>	No
Output	2-D DCT of the input	Same as Input port	No

If the data type of the input signal is floating point, the output of the block is the same data type. This block supports a signal represented by a Simulink virtual bus.

Use the **Sine and cosine computation** parameter to specify how the block computes the sine and cosine terms in the DCT algorithm. If you select `Trigonometric fcn`, the block computes the sine and cosine values during the simulation. If you select `Table lookup`, the block



computes and stores the trigonometric values before the simulation starts. In this case, the block requires extra memory.

### **Fixed-Point Data Types**

The following diagram shows the data types used within the 2-D DCT block for fixed-point signals. Inputs are first cast to the output data type and stored in the output buffer. Each butterfly stage processes signals in the accumulator data type, with the final output of the butterfly being cast back into the output data type.

# 2-D DCT

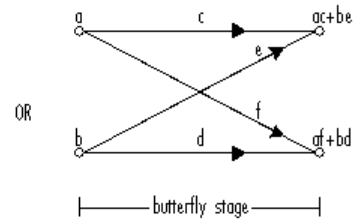
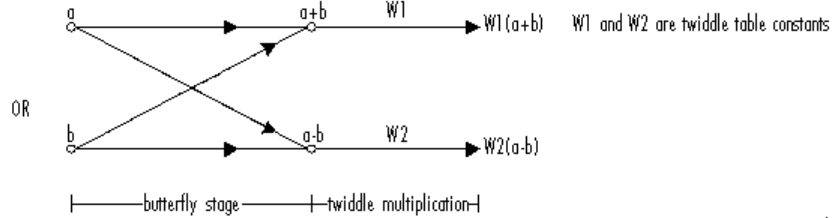
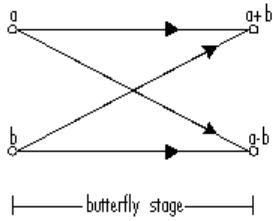

## Butterfly Stage Data Types

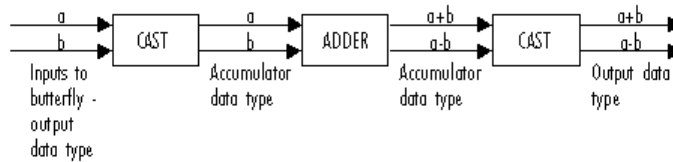

## Twiddle Multiplication Data Types

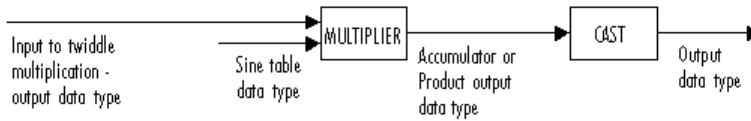

The output of the multiplier is in the product output data type when at least one of the inputs to the multiplier is real. When both of the inputs to the multiplier are complex, the result of the multiplication is in the accumulator data type. For details on the complex multiplication performed, refer to "Multiplication Data Types" in the Signal Processing Blockset documentation. You can set the sine table, product output, accumulator, and output data types in the block mask as discussed below.

## Dialog Box

The **Main** pane of the 2-D DCT block dialog appears as follows:

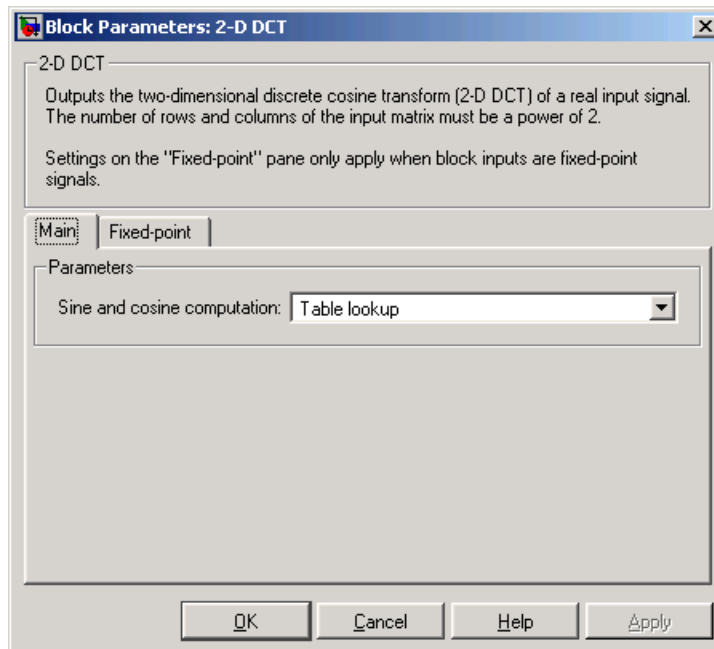

### Sine and cosine computation

Specify how the block computes the sine and cosine terms in the DCT algorithm. If you select *Trigonometric fcn*, the block computes the sine and cosine values during the simulation. If

## 2-D DCT

you select Table lookup, the block computes and stores the trigonometric values before the simulation starts. In this case, the block requires extra memory.

The **Fixed-point** pane of the 2-D DCT block dialog appears as follows:

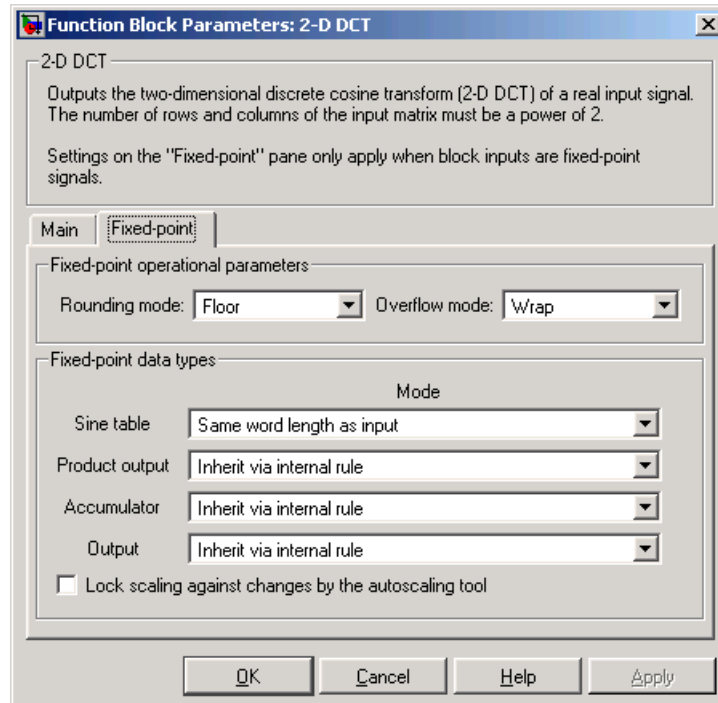

### Rounding mode

Select the rounding mode for fixed-point operations. The sine table values do not obey this parameter; they are always saturated and rounded to Nearest.

**Overflow mode**

Select the overflow mode for fixed-point operations. The sine table values do not obey this parameter; they are always saturated and rounded to Nearest.

**Sine table**

Choose how you will specify the word length of the values of the sine table. The fraction length of the sine table values is always equal to the word length minus one:

- When you select Same word length as input, the word length of the sine table values will match that of the input to the block.
- When you select Binary point scaling, you can enter the word length of the sine table values, in bits.
- When you select Slope and bias scaling, you can enter the word length of the sine table values, in bits.

The sine table values do not obey the **Rounding mode** and **Overflow mode** parameters; they are always saturated and rounded to Nearest.

**Product output**

Use this parameter to specify how you would like to designate the product output word and fraction lengths. Refer to "Fixed-Point Data Types" on page 9-43 and "Multiplication Data Types" in the Signal Processing Blockset documentation for illustrations depicting the use of the product output data type in this block:

- When you select Inherit via internal rule, the product output word length and fraction length are automatically set according to the following equations:

$$\textit{ideal product output word length} = \textit{output word length} + \textit{sine table values word length}$$

$$\textit{ideal product output fraction length} = \textit{output fraction length} + \textit{sine table values fraction length}$$

- When you select `Same as input`, these characteristics will match those of the input to the block.
- When you select `Binary point scaling`, you can enter the word length and the fraction length of the product output, in bits.
- When you select `Slope and bias scaling`, you can enter the word length, in bits, and the slope of the product output. The bias of all signals in the Signal Processing Blockset is zero.

### Accumulator

Use this parameter to specify how you would like to designate the accumulator word and fraction lengths. Refer to “Fixed-Point Data Types” on page 9-43 and "Multiplication Data Types" in the Signal Processing Blockset documentation for illustrations depicting the use of the accumulator data type in this block:

- When you select `Inherit via internal rule`, the accumulator word length and fraction length are automatically set according to the following equations:

$$\textit{ideal accumulator word length} = \textit{product output word length} + 1$$

$$\textit{ideal accumulator fraction length} = \textit{product output fraction length}$$

- When you select `Same as product output`, these characteristics will match those of the product output.
- When you select `Same as input`, these characteristics will match those of the input to the block.
- When you select `Binary point scaling`, you can enter the word length and the fraction length of the accumulator, in bits.
- When you select `Slope and bias scaling`, you can enter the word length, in bits, and the slope of the accumulator. The bias of all signals in the Signal Processing Blockset is zero.

### Output

Choose how you will specify the output word length and fraction length:

- When you select `Inherit` via `internal` rule, the output word length and fraction length are automatically set according to the following equations, where the input matrix is M-by-N:

If  $M > 1$  and  $N > 1$ ,  $output\ word\ length = input\ word\ length + \text{floor}(\log_2((M-1)(N-1))) + 1$

If  $M > 1$  and  $N = 1$ ,  $output\ word\ length = input\ word\ length + \text{floor}(\log_2(M-1)) + 1$

If  $M = 1$  and  $N > 1$ ,  $output\ word\ length = input\ word\ length + \text{floor}(\log_2(N-1)) + 1$

$output\ fraction\ length = input\ fraction\ length$

- When you select `Same` as `input`, these characteristics will match those of the input to the block.
- When you select `Binary point scaling`, you can enter the word length and the fraction length of the output, in bits.
- When you select `Slope and bias scaling`, you can enter the word length, in bits, and the slope of the output. The bias of all signals in the Signal Processing Blockset is zero.

#### **Lock scaling against changes by the autoscaling tool**

Select this parameter to prevent any fixed-point scaling you specify in this block mask from being overridden by the autoscaling tool in the Fixed-Point Settings interface. For more information about the autoscaling tool, refer to the Fixed-Point Settings Interface section of the Signal Processing Blockset User's Guide.

## **References**

Chen, W.H, C.H. Smith, and S.C. Fralick, "A fast computational algorithm for the discrete cosine transform," *IEEE Trans. Commun.*, vol. COM-25, pp. 1004-1009. 1977.

Wang, Z. "Fast algorithms for the discrete W transform and for the discrete Fourier transform," *IEEE Trans. Acoust., Speech, Signal Processing*, vol. ASSP-32, pp. 803-816, Aug. 1984.

## 2-D DCT

---

### See Also

2-D IDCT	Video and Image Processing Blockset
2-D FFT	Video and Image Processing Blockset
2-D IFFT	Video and Image Processing Blockset



**Purpose** Compute two-dimensional FFT of input

**Library** Transforms

**Description**

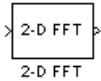

The 2-D FFT block computes the fast Fourier transform (FFT) of a two-dimensional M-by-N input matrix in two steps. First it computes the one-dimensional FFT along one dimension (row or column). Then it computes the FFT of the output of the first step along the other dimension (column or row). The dimensions of the input matrix, M and N, must be powers of 2. To work with other input sizes, use the Zero Pad block to pad or truncate these dimensions to powers of two.

The output of the 2-D FFT block is equivalent to the MATLAB `fft2` function:

```
y = fft2(A)      % Equivalent MATLAB code
```

Computing the FFT of each dimension of the input matrix is equivalent to calculating the two-dimensional discrete Fourier transform (DFT), which is defined by the following equation:

$$F(m, n) = \sum_{x=0}^{M-1} \sum_{y=0}^{N-1} f(x, y) e^{-j \frac{2\pi m x}{M}} e^{-j \frac{2\pi n y}{N}}$$

where  $0 \leq m \leq M - 1$  and  $0 \leq n \leq N - 1$ .

## 2-D FFT

---

<b>Port</b>	<b>Input/Output</b>	<b>Supported Data Types</b>	<b>Supports Complex Values?</b>
Input	Scalar, vector, or matrix of intensity values or a scalar, vector, or matrix that represents one plane of the RGB video stream	<ul style="list-style-type: none"><li>• Double-precision floating point</li><li>• Single-precision floating point</li><li>• Fixed point</li></ul>	Yes
Output	2-D FFT of the input	Same as Input port	Yes

If the data type of the input signal is floating point, the data type of the output signal is the same floating-point data type. Otherwise, the output can be any fixed-point data type. This block supports a signal represented by a Simulink virtual bus.

### Optimizing the Table of Trigonometric Values

The block computes all the possible trigonometric values of the twiddle factor,

$$e^{-j\frac{2\pi kx}{K}}$$

, where  $K$  is the greater value of either  $M$  or  $N$  and  $k = 0, \dots, K - 1$ . The block stores these values in a table and retrieves them during simulation. You can optimize the table of trigonometric values for memory or speed using the **Optimize table for** parameter. This parameter varies the number of table entries as summarized below.

Optimize Table for Parameter Setting	Number of Table Entries for N-Point FFT
Speed	$3N/4$ – floating point $N$ – fixed point
Memory	$N/4$ – floating point Not supported for fixed point

### Ordering Output Column Entries

Use the **Output in bit-reversed order** parameter to specify the ordering of the column elements of the output as either linear or bit-reversed. If you select the **Output in bit-reversed order** check box, the row and column elements are output in bit-reversed order. This means that the  $m$ th row element is located at the  $k$ th position, where  $k$  is the bit reversed value of  $m$ . Also, the  $n$ th column element is located at the  $l$ th position, where  $l$  is the bit reversed value of  $n$ . If you clear the **Output in bit-reversed order** check box, the channel elements are output in linear order.

## 2-D FFT

---

---

**Note** With the 2-D FFT block, linearly ordering the output requires a butterfly operation. So, it might be better to output in bit-reversed order in some situations.

---

For more information ordering of the output, see "Linear and Bit-Reversed Output Order" in the Signal Processing Blockset User's Guide. Note that the 2-D FFT block bit-reverses the order of the columns as well as the rows.

### Algorithms Used for FFT Computation

Depending on whether the block input is floating-point or fixed-point, real- or complex-valued, and whether you want the output in linear or bit-reversed order, the block uses one or more of the following algorithms as summarized in the following tables:

- Butterfly operation
- Double-signal algorithm
- Half-length algorithm
- Radix-2 decimation-in-time (DIT) algorithm
- Radix-2 decimation-in-frequency (DIF) algorithm

### For floating-point signals:

Complexity of Input	Output Ordering	Algorithms Used for FFT Computation
Complex	Linear	Butterfly operation and radix-2 DIT
Complex	Bit-reversed	Radix-2 DIF

Complexity of Input	Output Ordering	Algorithms Used for FFT Computation
Real	Linear	Butterfly operation and radix-2 DIT in conjunction with the half-length and double-signal algorithms
Real	Bit-reversed	Radix-2 DIF in conjunction with the half-length and double-signal algorithms

**For fixed-point signals:**

Complexity of Input	Output Ordering	Algorithms Used for FFT Computation
Real or complex	Linear	Butterfly operation and radix-2 DIT
Real or complex	Bit-reversed	Radix-2 DIF

### **Fixed-Point Data Types**

The diagrams below show the data types used within the 2-D FFT block for fixed-point signals. You can set the sine table, accumulator, product output, and output data types displayed in the diagrams in the 2-D FFT block dialog as discussed in “Dialog Box” on page 9-47.

Inputs to the 2-D FFT block are first cast to the output data type and stored in the output buffer. Each butterfly stage then processes signals in the accumulator data type, with the final output of the butterfly being cast back into the output data type. A twiddle factor is multiplied in before each butterfly stage in a decimation-in-time FFT, and after each butterfly stage in a decimation-in-frequency FFT.

# 2-D FFT

Decimation-in-time FFT

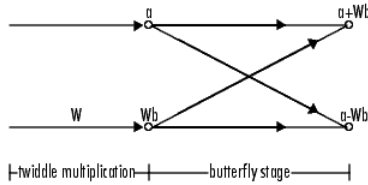

Decimation-in-frequency FFT

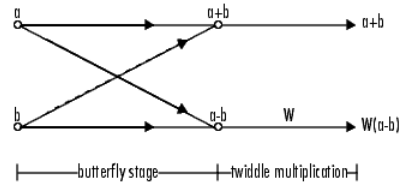

Butterfly stage data types

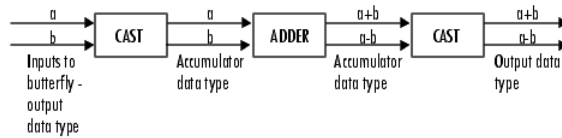

Twiddle multiplication data types



The output of the multiplier is in the accumulator data type since both of the inputs to the multiplier are complex. For details on the complex multiplication performed, refer to "Multiplication Data Types" in the Signal Processing Blockset documentation.

## Example

### Bit-Reversed Order

Two numbers are bit-reversed values of each other when the binary representation of one is the mirror image of the binary representation of the other. For example, in a three-bit system, one and four are bit-reversed values of each other, since the three-bit binary representation of one, 001, is the mirror image of the three-bit binary

representation of four, 100. In the diagram below, the row indices are in linear order. To put them in bit-reversed order

- 1 Translate the indices into their binary representation with the minimum number of bits. In this example, the minimum number of bits is three because the binary representation of 7 is 111.
- 2 Find the mirror image of each binary entry, and write it beside the original binary representation.
- 3 Translate the indices back to their decimal representation.

The row indices are now in bit-reversed order.

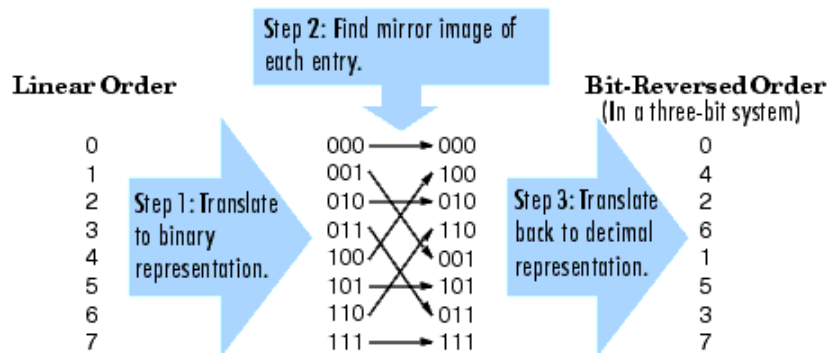

If, on the 2-D FFT block parameters dialog box, you select the **Output in bit-reversed order** check box, the block bit-reverses the order of the columns as well as the rows. The next diagram illustrates the linear and bit-reversed outputs of the 2-D FFT block. The output values are the same, but they appear in different order.

# 2-D FFT

Input to FFT block  
(must be linear order)

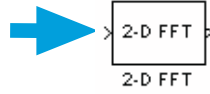
$$\begin{bmatrix} 7 & 6 & 7 & 1 & 3 & 6 & 2 & 3 \\ 1 & 3 & 7 & 8 & 7 & 0 & 1 & 6 \\ 4 & 4 & 3 & 1 & 3 & 5 & 1 & 6 \\ 3 & 6 & 7 & 4 & 3 & 3 & 5 & 4 \\ 7 & 7 & 0 & 2 & 6 & 6 & 2 & 3 \\ 6 & 5 & 2 & 1 & 4 & 4 & 4 & 7 \\ 3 & 1 & 6 & 0 & 1 & 5 & 1 & 6 \\ 0 & 3 & 0 & 5 & 5 & 3 & 5 & 5 \end{bmatrix}$$

Output in linear order

Output in bit-reversed order

Output in linear order

Linearly ordered row and column indices	0	1	2	3	4	5	6	7
	↓	↓	↓	↓	↓	↓	↓	↓
0 →	245	13.9 - 0.4i	10 - 5i	-15.9 + 21.6i	-13	-15.9 - 21.6i	10 + 5i	13.9
1 →	-4.3 - 10.3i	-27.6 - 6.6i	-5.6 + 13.1i	-3.4 + 8.7i	1.1 - i	-2.6i	-11.5 - 11i	6.2 + 13i
2 →	18 - 5i	-4.3 - 10.4i	19 - 24i	12.4 - 11.4i	6 - 3i	-5.7 + 16.4i	5 + 4i	5.5 + 1.4i
3 →	8.4 - 2.4i	-0.6 + 2.7i	-4.5 + 1.1i	17.6 + 9.4i	11 - 9i	-2.2 - 13i	-18.4 + 25.1i	34 + 0.5i
4 →	-9	16.3 + 5.9i	14 - 31i	17.7 + 23.9i	1	17.7 - 23.9i	14 + 31i	16.3 - 5.9i
5 →	8.4 + 2.4i	3.4 - 5.4i	-18.4 - 25.1i	-2.2 + 13.1i	11 + 9i	17.6 - 9.4i	-4.5 - 1.1i	-1 - 2.7i
6 →	18 + 5i	5.5 - 1.4i	5 - 4i	-5.7 - 16.4i	6 + 3i	12.5 + 11.3i	19 + 24i	-4.3 + 10.4i
7 →	-4.4 + 10.3i	6.2 - 13i	-11.5 + 11i	2.6i	1.1 + i	-3.4 - 8.7i	-5.6 - 13.1i	-27.6 + 6.6i

Output in bit-reversed order

Bit-reversed row and column indices	0	1	2	3	4	5	6	7
	↓	↓	↓	↓	↓	↓	↓	↓
0 →	245	-13	10 - 5i	10 + 5i	13.9 - 0.4i	-15.9 - 21.6i	-15.9 + 21.6i	13.9
1 →	-9	1	14 - 31i	14 + 31i	16.3 + 5.9i	17.7 - 23.9i	17.7 + 23.9i	16.3 - 5.9i
2 →	18 - 5i	6 - 3i	19 - 24i	5 + 4i	-4.3 - 10.4i	-5.7 + 16.4i	12.4 - 11.4i	5.5 + 1.4i
3 →	18 + 5i	6 + 3i	5 - 4i	19 + 24i	5.5 - 1.4i	12.5 + 11.3i	-5.7 - 16.4i	34 + 0.5i
4 →	-4.3 - 10.3i	1.1 - i	-5.6 + 13.1i	-11.5 - 11i	-27.6 - 6.6i	-2.6i	-3.4 + 8.7i	6.2 + 13i
5 →	8.4 + 2.4i	11 + 9i	-18.4 - 25.1i	-4.5 - 1.1i	3.4 - 5.4i	17.6 - 9.4i	-2.2 + 13i	-1 - 2.7i
6 →	8.4 - 2.4i	11 - 9i	-4.5 + 1.1i	-18.4 + 25.1i	-0.6 + 2.7i	-2.2 - 13i	17.6 + 9.4i	34 + 0.5i
7 →	-4.4 + 10.3i	1.1 + i	-11.5 + 11i	-5.6 - 13.1i	6.2 - 13i	-3.4 - 8.7i	2.6i	-27.6 + 6.6i



## Dialog Box

The **Main** pane of the 2-D FFT block dialog appears as follows:

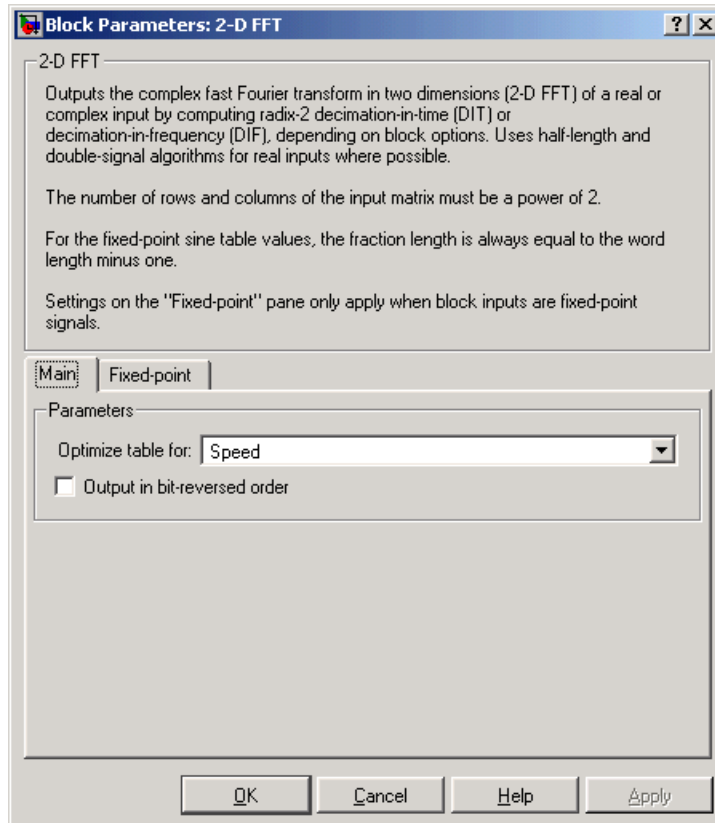

### Optimize table for

Optimize of the table of twiddle factor values for Speed or Memory. This parameter must be set to Speed for fixed-point signals.

### Output in bit-reversed order

Designate the order of the output channel elements relative to the ordering of the input elements. When selected, the output channel elements are in bit-reversed order relative to the input ordering.

Otherwise, the output column elements are linearly ordered relative to the input ordering. Linearly ordering the output requires extra data sorting manipulation. For more information, see “Bit-Reversed Order” on page 9-44.

The **Fixed-point** pane of the 2-D FFT block dialog appears as follows:

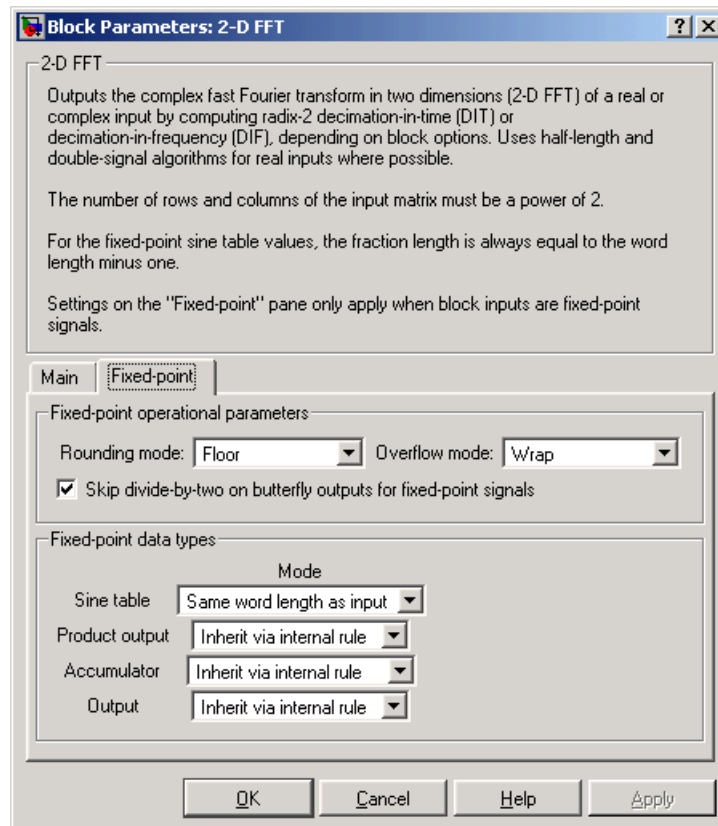

### Rounding mode

Select the rounding mode for fixed-point operations. The sine table values do not obey this parameter; they always round to Nearest.

### Overflow mode

Select the overflow mode for fixed-point operations. The sine table values do not obey this parameter; they are always saturated.

### Skip divide-by-two on butterfly outputs for fixed-point signals

When this parameter is selected, no scaling occurs. When this parameter is not selected, the output of each butterfly of the FFT is divided by two for fixed-point signals.

### Sine table

Choose how you will specify the word length of the values of the sine table. The fraction length of the sine table values is always equal to the word length minus one:

- When you select Same word length as input, the word length of the sine table values will match that of the input to the block.
- When you select Binary point scaling, you can enter the word length of the sine table values, in bits.
- When you select Slope and bias scaling, you can enter the word length of the sine table values, in bits.

The sine table values do not obey the **Rounding mode** and **Overflow mode** parameters; they are always saturated and rounded to Nearest.

### Product output

Use this parameter to specify how you would like to designate the product output word and fraction lengths. Refer to "Fixed-Point Data Types" on page 9-43 and "Multiplication Data Types" in the Signal Processing Blockset documentation for illustrations depicting the use of the product output data type in this block:

- When you select Inherit via internal rule, the product output word length and fraction length are automatically set according to the following equations:

$$\begin{aligned} \textit{ideal product output word length} &= \\ \textit{output word length} + \textit{sine table values word length} \end{aligned}$$

$$\textit{ideal product output fraction length} = \textit{output fraction length} + \textit{sine table values fraction length}$$

- When you select `Same as input`, these characteristics will match those of the input to the block.
- When you select `Binary point scaling`, you can enter the word length and the fraction length of the product output, in bits.
- When you select `Slope and bias scaling`, you can enter the word length, in bits, and the slope of the product output. The bias of all signals in the Signal Processing Blockset is zero.

### **Accumulator**

Use this parameter to specify how you would like to designate the accumulator word and fraction lengths. Refer to “Fixed-Point Data Types” on page 9-43 and “Multiplication Data Types” in the Signal Processing Blockset documentation for illustrations depicting the use of the accumulator data type in this block:

- When you select `Inherit via internal rule`, the accumulator word length and fraction length are automatically set according to the following equations:

$$\textit{ideal accumulator word length} = \textit{product output word length} + 1$$

$$\textit{ideal accumulator fraction length} = \textit{product output fraction length}$$

- When you select `Same as product output`, these characteristics will match those of the product output.
- When you select `Same as input`, these characteristics will match those of the input to the block.
- When you select `Binary point scaling`, you can enter the word length and the fraction length of the accumulator, in bits.
- When you select `Slope and bias scaling`, you can enter the word length, in bits, and the slope of the accumulator. The bias of all signals in the Signal Processing Blockset is zero.

## Output

Choose how you will specify the output word length and fraction length:

- When you select `Inherit` via internal rule, the output word length and fraction length are automatically set according to the following equations, where the input matrix is M-by-N:

If  $M > 1$  and  $N > 1$ , *output word length* = *input word length* +  $\text{floor}(\log_2((M-1)(N-1))) + 1$

If  $M > 1$  and  $N = 1$ , *output word length* = *input word length* +  $\text{floor}(\log_2(M-1)) + 1$

If  $M = 1$  and  $N > 1$ , *output word length* = *input word length* +  $\text{floor}(\log_2(N-1)) + 1$

*output fraction length* = *input fraction length*

- When you select `Same` as input, these characteristics will match those of the input to the block.
- When you select `Binary point scaling`, you can enter the word length and the fraction length of the output, in bits.
- When you select `Slope and bias scaling`, you can enter the word length, in bits, and the slope of the output. The bias of all signals in the Signal Processing Blockset is zero.

## See Also

2-D DCT	Video and Image Processing Blockset
2-D IDCT	Video and Image Processing Blockset
2-D IFFT	Video and Image Processing Blockset
FFT	Signal Processing Blockset
IFFT	Signal Processing Blockset
Zero Pad	Signal Processing Blockset
bitrevorder	Signal Processing Toolbox

## 2-D FFT

---

<code>fft</code>	Signal Processing Toolbox
<code>ifft</code>	Signal Processing Toolbox

**Purpose** Perform two-dimensional FIR filtering on input matrix

**Library** Filtering

**Description** The 2-D FIR Filter block filters the input matrix I using coefficient matrix H.

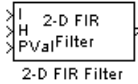

Port	Input/Output	Supported Data Types	Supports Complex Values?
I	Scalar, vector, or matrix of intensity values or a scalar, vector, or matrix that represents one plane of the RGB video stream	<ul style="list-style-type: none"> <li>• Double-precision floating point</li> <li>• Single-precision floating point</li> <li>• Fixed point</li> </ul>	Yes
H	Scalar, vector, or matrix of intensity values or a scalar, vector, or matrix that represents one plane of the RGB video stream	Same as I port	Yes
PVal	Scalar that represents the constant pad value	Input must have the same data type as the input to port I	Yes
Output	Scalar, vector, or matrix of filtered values	Same as I port	Yes

If the data type of the input is floating point, the output of the block is the same data type. Otherwise, the output can be any fixed-point data type. This block supports a signal represented by a Simulink virtual bus.

Use the **Coefficient source** parameter to specify how you want to define your filter coefficients. If you select Specify via dialog, the **Coefficients** parameter appears on the dialog box. Use this parameter

## 2-D FIR Filter

---

to enter your matrix of filter coefficients. If you select Input port, port H appears on the block. Use this port to specify your filter coefficient matrix.

The block outputs the result of the filtering operation at the Output port. The dimensions of the output are dictated by the **Output size** parameter and the sizes of the inputs at ports I and H. For example, assume that the input at port I has dimensions  $(M_i, N_i)$  and the input at port H has dimensions  $(M_h, N_h)$ . If, for the **Output size** parameter, you choose Full, the output has dimensions  $(M_i+M_h-1, N_i+N_h-1)$ . If, for the **Output size** parameter, you choose Same as input port I, the output has the same dimensions as the input at port I. If, for the **Output size** parameter, you choose Valid, the block filters the input image only where the coefficient matrix fits entirely within it, so no padding is required. The output has dimensions  $(M_i-M_h+1, N_i-N_h+1)$ . However, if  $\text{all}(\text{size}(I) < \text{size}(H))$ , the block errors out.

Use the **Padding options** parameter to specify how to pad the boundary of your input matrix. To pad your matrix with a constant value, select Constant. To pad your input matrix by repeating its border values, select Replicate. To pad your input matrix with its mirror image, select Symmetric. To pad your input matrix using a circular repetition of its elements, select Circular. For more information on padding, see the 2-D Pad block reference page.

If, for the **Padding options** parameter, you select Constant, the **Pad value source** parameter appears on the dialog box. If you select Specify via dialog, the **Pad value** parameter appears on the dialog box. Use this parameter to enter the constant value with which to pad your matrix. If, for the **Pad value source** parameter, you select Input port, the PVal port appears on the block. Use this port to specify the constant value with which to pad your matrix.

Use the **Filtering based on** parameter to specify the algorithm by which the block filters the input matrix. If you select Convolution and set the **Output size** parameter to Full, the block filters your input using the following algorithm



$$C(i, j) = \sum_{m=0}^{(Ma-1)(Na-1)} \sum_{n=0}^{(Na-1)} A(m, n) * H(i - m, j - n)$$

where  $0 \leq i < Ma + Mh - 1$  and  $0 \leq j < Na + Nh - 1$ . If you select **Correlation** and set the **Output size** parameter to **Full**, the block filters your input using the following algorithm

$$C(i, j) = \sum_{m=0}^{(Ma-1)(Na-1)} \sum_{n=0}^{(Na-1)} A(m, n) \cdot \text{conj}(H(m + i, n + j))$$

where  $0 \leq i < Ma + Mh - 1$  and  $0 \leq j < Na + Nh - 1$ .

### Fixed-Point Data Types

The following diagram shows the data types used within the 2-D FIR Filter block for fixed-point signals.

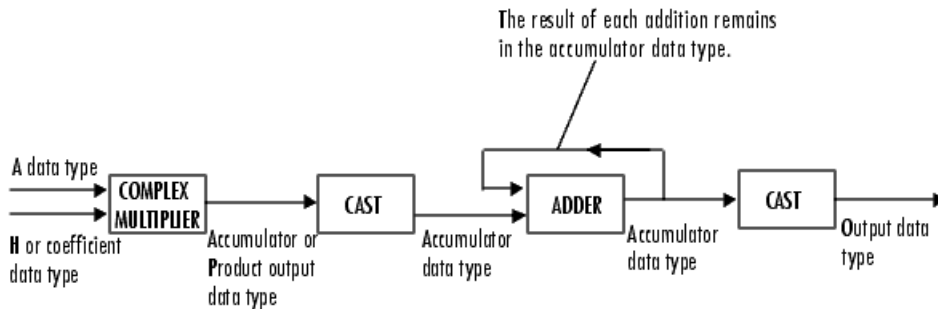

You can set the coefficient, product output, accumulator, and output data types in the block mask as discussed in "Dialog Box" on page 9-56.

The output of the multiplier is in the product output data type if at least one of the inputs to the multiplier is real. If both of the inputs to the multiplier are complex, the result of the multiplication is in the accumulator data type. For details on the complex multiplication

## 2-D FIR Filter

performed, refer to "Multiplication Data Types" in the Signal Processing Blockset documentation.

### Dialog Box

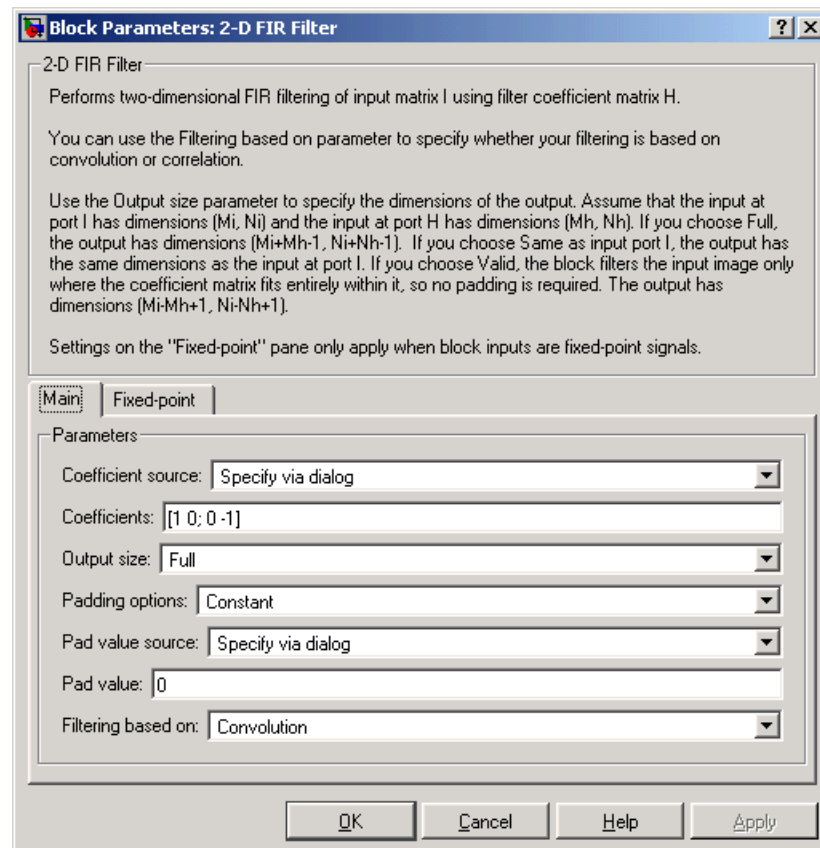

### Coefficient source

Specify how to define your filter coefficients. Select Specify via dialog to enter your coefficients in the block parameters dialog box. Select Input port to specify your filter coefficient matrix using port H.

### **Coefficients**

Enter your real or complex-valued filter coefficient matrix. This parameter is visible if, for the **Coefficient source** parameter, you select Specify via dialog. Tunable.

### **Output size**

This parameter controls the size of the filtered output. If you choose Full, the output has dimensions  $(M_a+M_h-1, N_a+N_h-1)$ . If you choose Same as input port I, the output has the same dimensions as the input at port I. If you choose Valid, output has dimensions  $(M_a-M_h+1, N_a-N_h+1)$ .

### **Padding options**

Specify how to pad the boundary of your input matrix. Select Constant to pad your matrix with a constant value. Select Replicate to pad your input matrix by repeating its border values. Select Symmetric to pad your input matrix with its mirror image. Select Circular to pad your input matrix using a circular repetition of its elements. This parameter is visible if, for the **Output size** parameter, you select Full or Same as input port I.

### **Pad value source**

Use this parameter to specify how to define your constant boundary value. Select Specify via dialog to enter your value in the block parameters dialog box. Select Input port to specify your constant value using the PVal port. This parameter is visible if, for the **Padding options** parameter, you select Constant.

### **Pad value**

Enter the constant value with which to pad your matrix. This parameter is visible if, for the **Pad value source** parameter, you select Specify via dialog. Tunable.

### **Filtering based on**

Specify the algorithm by which the block filters the input matrix. You can select Convolution or Correlation.

## 2-D FIR Filter

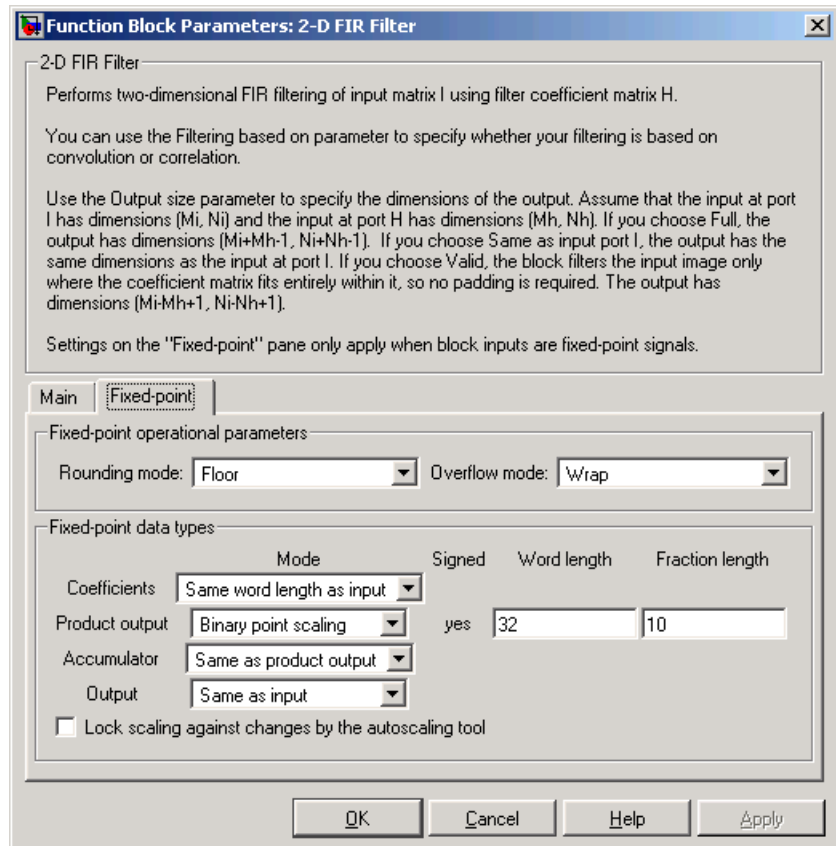

### **Rounding mode**

Select the rounding mode for fixed-point operations.

### **Overflow mode**

Select the overflow mode for fixed-point operations.

### **Coefficients**

Choose how you will specify the word length and the fraction length of the filter coefficients.

- When you select **Same word length as input**, the word length of the filter coefficients will match that of the input to the block. In this mode, the fraction length of the coefficients is automatically set to the binary-point only scaling that provides you with the best precision possible given the value and word length of the coefficients.
- When you select **Specify word length**, you can enter the word length of the coefficients, in bits. In this mode, the fraction length of the coefficients is automatically set to the binary-point only scaling that provides you with the best precision possible given the value and word length of the coefficients.
- When you select **Binary point scaling**, you can enter the word length and the fraction length of the coefficients, in bits.
- When you select **Slope and bias scaling**, you can enter the word length, in bits, and the slope of the coefficients. The bias of all signals in the Signal Processing Blockset is zero.

The filter coefficients do not obey the **Rounding mode** and the **Overflow mode** parameters; they are always saturated and rounded to Nearest.

### Product output

Use this parameter to specify how you would like to designate the product output word and fraction lengths. Refer to “Fixed-Point Data Types” on page 9-55 and “Multiplication Data Types” in the Signal Processing Blockset documentation for illustrations depicting the use of the product output data type in this block:

- When you select **Same as input**, these characteristics will match those of the input to the block.
- When you select **Binary point scaling**, you can enter the word length and the fraction length of the product output, in bits.

## 2-D FIR Filter

---

- When you select **Slope and bias scaling**, you can enter the word length, in bits, and the slope of the product output. The bias of all signals in the Signal Processing Blockset is zero.

### **Accumulator**

Use this parameter to specify how you would like to designate the accumulator word and fraction lengths. Refer to “Fixed-Point Data Types” on page 9-55 and “Multiplication Data Types” in the Signal Processing Blockset documentation for illustrations depicting the use of the accumulator data type in this block. Note that the accumulator data type is only used when both inputs to the multiplier are complex:

- When you select **Same as product output**, these characteristics will match those of the product output.
- When you select **Same as input**, these characteristics will match those of the input to the block.
- When you select **Binary point scaling**, you can enter the word length and the fraction length of the accumulator, in bits.
- When you select **Slope and bias scaling**, you can enter the word length, in bits, and the slope of the accumulator. The bias of all signals in the Signal Processing Blockset is zero.

### **Output**

Choose how you will specify the word length and fraction length of the output of the block:

- When you select **Same as input**, these characteristics will match those of the input to the block.
- When you select **Binary point scaling**, you can enter the word length and the fraction length of the output, in bits.
- When you select **Slope and bias scaling**, you can enter the word length, in bits, and the slope of the output. The bias of all signals in the Signal Processing Blockset is zero.

### **Lock scaling against changes by the autoscaling tool**

Select this parameter to prevent any fixed-point scaling you specify in this block mask from being overridden by the autoscaling tool in the Fixed-Point Settings interface. For more information about the autoscaling tool, refer to the “Fixed-Point Settings Interface” section of the Signal Processing Blockset User’s Guide.

## 2-D Histogram

**Purpose** Generate histogram of each input matrix

**Library** Statistics

### Description

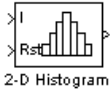

The 2-D Histogram block computes the frequency distribution of the elements in each input matrix or in a sequence of inputs over a period of time. Use the **Running histogram** check box to select between the block's basic and running operation.

The output of the 2-D Histogram block is different than the output of the `imhist` function in the Image Processing Toolbox. For intensity images, the `imhist` function defines the  $p$ th bin boundaries as

$$\frac{A(p-1.5)}{(N-1)} \leq x < \frac{A(p-0.5)}{(N-1)}$$

where  $A$  is maximum value of the data type,  $N$  is the number of bins in the histogram, and  $p$  starts from 1. The 2-D Histogram block defines bin boundaries as

$$\frac{A(p-1)}{N} < x \leq \frac{Ap}{N}$$

where  $A$  corresponds to the **Maximum value of input** parameter and the **Minimum value of input** parameter is assumed to be zero.

Port	Input/Output	Supported Data Types	Supports Complex Values?
Input / I	Scalar, vector, or matrix of intensity values or scalar, vector, or matrix that represents one plane of the input RGB video stream	<ul style="list-style-type: none"> <li>• Double-precision floating point</li> <li>• Single-precision floating point</li> <li>• Fixed point</li> <li>• 8-, 16-, and 32-bit signed integers</li> <li>• 8-, 16-, and 32-bit unsigned integers</li> </ul>	Yes
Rst	Signal that triggers a	<ul style="list-style-type: none"> <li>• Double-precision floating point</li> </ul>	No



Port	Input/Output	Supported Data Types	Supports Complex Values?
	reset event	<ul style="list-style-type: none"> <li>• Single-precision floating point</li> <li>• Boolean</li> <li>• 8-, 16-, and 32-bit signed integers</li> <li>• 8-, 16-, and 32-bit unsigned integers</li> </ul>	
Output	Sample-based 1-by-N vector that represents the frequency distribution of each M-by-N input matrix or the frequency distributions in a series of M-by-N inputs	Same as Input port	No

Length-M 1-D vector inputs are treated as M-by-1 column vectors. This block supports a signal represented by a Simulink virtual bus.

The block sorts the elements of each input matrix into the number of discrete bins,  $n$ , specified by the **Number of bins** parameter. Complex inputs are sorted by their magnitude squared values.

The histogram value for a given bin represents the frequency of occurrence of the input values bracketed by that bin. You specify the upper-boundary of the highest-valued bin in the **Maximum value of input** parameter,  $B_M$ , and the lower-boundary of the lowest-valued bin in the **Minimum value of input** parameter,  $B_m$ . The bins have equal width of

$$\Delta = \frac{B_M - B_m}{n}$$

where  $n$  is the number of bins. The centers are located at

## 2-D Histogram

---

$$B_m + \left(k + \frac{1}{2}\right)\Delta \quad k = 0, 1, 2, \dots, n - 1$$

Input values that fall on the border between two bins are sorted into the lower-valued bin; that is, each bin includes its upper boundary. For example, a bin of width 4 centered on the value 5 contains the input value 7, but not the input value 3. Input values greater than the **Maximum value of input** parameter or less than **Minimum value of input** parameter are sorted into the highest-valued or lowest-valued bin, respectively. The values you enter for the **Maximum value of input** and **Minimum value of input** parameters must be real-valued scalars.

### Basic Operation

If you clear the **Running histogram** check box, the block computes the frequency distribution of each M-by-N input matrix and outputs a sample-based 1-by-N vector.

For example, if your input is  $\begin{bmatrix} 1 & 1 & 1 \\ 2 & 2 & 2 \\ 3 & 3 & 3 \end{bmatrix}$  and you set the block parameters as follows:

- **Minimum value of input** = 0
- **Maximum value of input** = 4
- **Number of bins** = 4

The block outputs [3 3 3 0].

If you select the **Normalized** check box, the block scales each element of the output so that  $\text{sum}(v)$  is 1, where  $v$  is the output vector.

### Running Operation

If you select the **Running histogram** check box, the block computes the frequency distributions in a series of M-by-N inputs.

For example, if your first input is  $\begin{bmatrix} 1 & 1 & 1 \\ 2 & 2 & 2 \\ 3 & 3 & 3 \end{bmatrix}$ , your second and current input is  $\begin{bmatrix} 2 & 2 & 2 \\ 3 & 3 & 3 \\ 4 & 4 & 4 \end{bmatrix}$ , and you set the block parameters as follows:

- **Minimum value of input** = 0
- **Maximum value of input** = 4
- **Number of bins** = 4

The block outputs [3 6 6 3]. For the next input, the block computes the frequency distribution for the first three inputs, and so on.

### Resetting the Running Histogram

The block resets the running histogram whenever a reset event is detected at the optional Rst port. The reset signal and the input data signal must be the same rate.

To enable the Rst port, select the **Reset port** parameter. You specify the reset event in the **Trigger type** parameter, and can be one of the following:

- **Rising edge** – Triggers a reset operation when the Rst input does one of the following:
  - Rises from a negative value to a positive value or zero
  - Rises from zero to a positive value, where the rise is not a continuation of a rise from a negative value to zero (see the following figure)

## 2-D Histogram

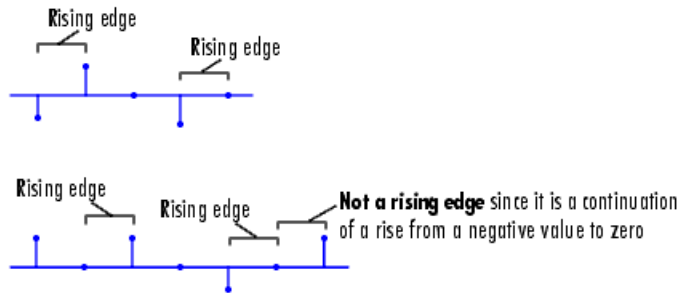

- Falling edge – Triggers a reset operation when the Rst input does one of the following:
  - Falls from a positive value to a negative value or zero
  - Falls from zero to a negative value, where the fall is not a continuation of a fall from a positive value to zero (see the following figure)

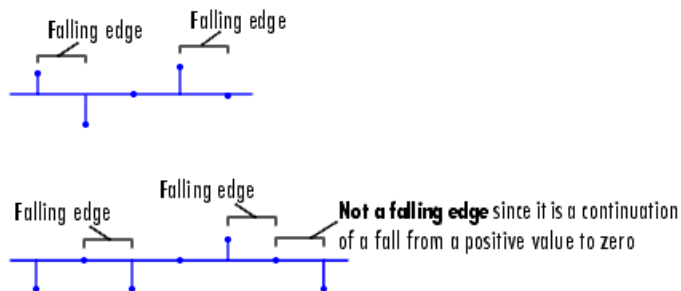

- Either edge – Triggers a reset operation when the Rst input is a Rising edge or Falling edge (as described above)
- Non-zero sample – Triggers a reset operation at each sample time that the Rst input is not zero

---

**Note** When running simulations in the Simulink MultiTasking mode, sample-based reset signals have a one-sample latency, and frame-based reset signals have one frame of latency. Thus, there is a one-sample or one-frame delay between the time the block detects a reset event, and when it applies the reset. For more information on latency and the Simulink tasking modes, see "The Configuration Parameters Dialog Box" in the Simulink documentation.

---

## Dialog Box

The **Main** pane of the 2-D Histogram block dialog box appears as follows:

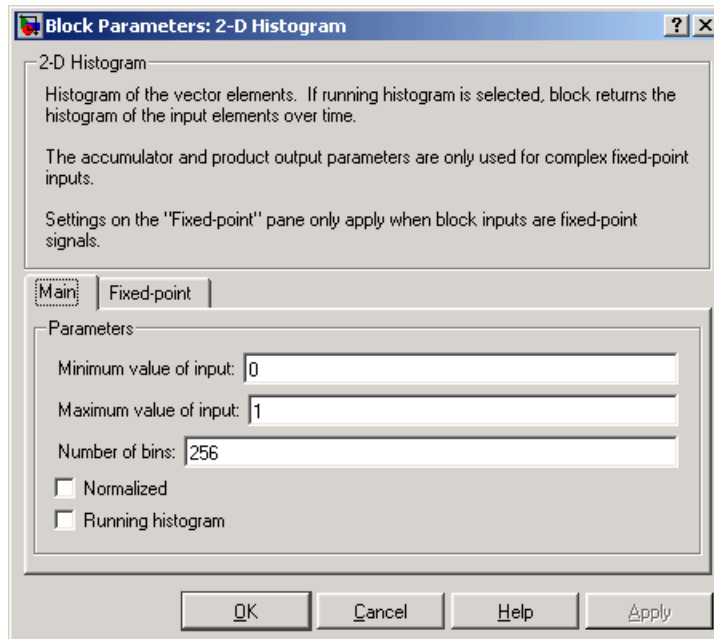

## 2-D Histogram

---

### Minimum value of input

Enter a real-valued scalar for the lower boundary,  $B_m$ , of the lowest-valued bin. Tunable.

### Maximum value of input

Enter a real-valued scalar for the upper boundary,  $B_M$ , of the highest-valued bin. Tunable.

### Number of bins

Enter the number of bins,  $n$ , in the histogram.

### Normalized

If you select this check box, the block normalizes the output vector (1-norm). Tunable.

Use of this parameter is not supported for fixed-point signals.

### Running histogram

Select this check box to enable the block's running histogram operation.

### Reset port

Enables the Rst input port when selected. The reset signal and the input data signal must be the same rate. This parameter is visible if you select the **Running histogram** check box.

### Trigger type

The type of event that resets the running histogram. For more information, see "Resetting the Running Histogram" on page 9-65. This parameter is enabled only when you set the **Reset port** parameter.

The **Fixed-point** pane of the 2-D Histogram block dialog box appears as follows:

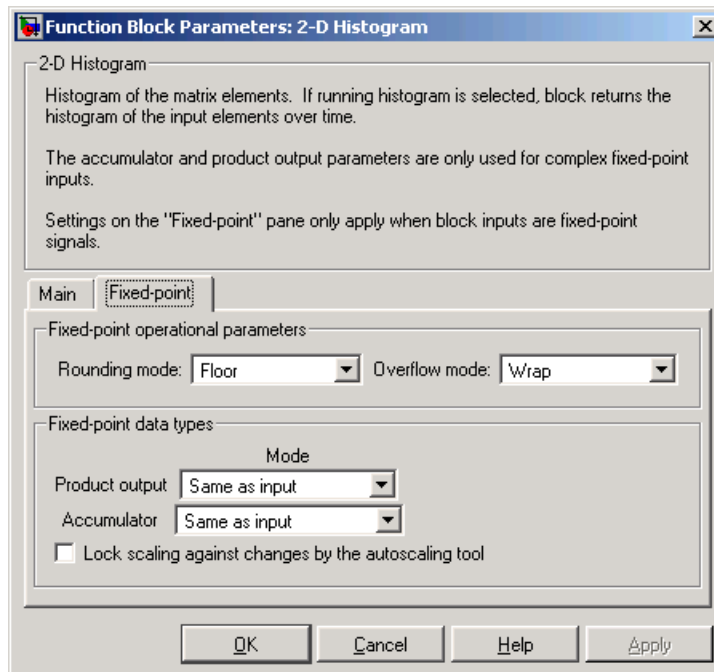

---

**Note** The fixed-point parameters listed below are only used for fixed-point complex inputs, which are sorted by squared magnitude.

---

### **Rounding mode**

Select the rounding mode for fixed-point operations.

### **Overflow mode**

Select the overflow mode for fixed-point operations.

### **Product output**

Use this parameter to specify how you would like to designate the product output word and fraction lengths:

## 2-D Histogram

---

- When you select `Same as input`, these characteristics will match those of the input to the block.
- When you select `Binary point scaling`, you can enter the word length and the fraction length of the product output, in bits.
- When you select `Slope and bias scaling`, you can enter the word length, in bits, and the slope of the product output. This block requires power-of-two slope and a bias of zero.

### **Accumulator**

Use this parameter to specify the accumulator word and fraction lengths resulting from a complex-complex multiplication in the block:

- When you select `Same as product output`, these characteristics will match those of the product output
- When you select `Same as input`, these characteristics will match those of the input to the block.
- When you select `Binary point scaling`, you can enter the word length and the fraction length of the accumulator, in bits.
- When you select `Slope and bias scaling`, you can enter the word length, in bits, and the slope of the accumulator. This block requires power-of-two slope and a bias of zero.

### **Lock scaling against changes by the autoscaling tool**

Select this parameter to prevent any fixed-point scaling you specify in this block mask from being overridden by the autoscaling tool in the Fixed-Point Settings interface. For more information about the autoscaling tool, refer to the Fixed-Point Settings Interface section of the Signal Processing Blockset User's Guide.

### **See Also**

2-D Autocorrelation	Video and Image Processing Blockset
2-D Correlation	Video and Image Processing Blockset



2-D Maximum	Video and Image Processing Blockset
2-D Mean	Video and Image Processing Blockset
2-D Median	Video and Image Processing Blockset
2-D Minimum	Video and Image Processing Blockset
2-D Standard Deviation	Video and Image Processing Blockset
2-D Variance	Video and Image Processing Blockset
Histogram	Signal Processing Blockset
hist	MATLAB
imhist	Image Processing Toolbox

## 2-D IDCT

**Purpose** Compute two-dimensional inverse discrete cosine transform (IDCT)

**Library** Transforms

**Description** The 2-D IDCT block calculates the two-dimensional inverse discrete cosine transform of the input signal. The equation for the two-dimensional IDCT is

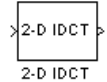

$$f(x, y) = \frac{2}{\sqrt{MN}} \sum_{m=0}^{M-1} \sum_{n=0}^{N-1} C(m)C(n)F(m, n) \cos \frac{(2x+1)m\pi}{2M} \cos \frac{(2y+1)n\pi}{2N}$$

where  $F(m, n)$  is the DCT of the signal  $f(x, y)$  and  $C(m), C(n) = \frac{1}{\sqrt{2}}$  for  $m, n = 0$  and  $C(m), C(n) = 1$  otherwise.

The number of rows and columns of the input signal must be powers of two. The output of this block has dimensions the same dimensions as the input.

Port	Input/Output	Supported Data Types	Supports Complex Values?
Input	Scalar, vector, or matrix of intensity values or a scalar, vector, or matrix that represents one plane of the RGB video stream	<ul style="list-style-type: none"> <li>• Double-precision floating point</li> <li>• Single-precision floating point</li> <li>• Fixed point</li> </ul>	No
Output	2-D IDCT of the input	Same as Input port	No

If the data type of the input signal is floating point, the output of the block is the same data type. This block supports a signal represented by a Simulink virtual bus.

Use the **Sine and cosine computation** parameter to specify how the block computes the sine and cosine terms in the IDCT algorithm. If you select `Trigonometric fcn`, the block computes the sine and cosine values during the simulation. If you select `Table lookup`, the block computes and stores the trigonometric values before the simulation starts. In this case, the block requires extra memory.

### **Fixed-Point Data Types**

The following diagram shows the data types used within the 2-D IDCT block for fixed-point signals. Inputs are first cast to the output data type and stored in the output buffer. Each butterfly stage processes signals in the accumulator data type, with the final output of the butterfly being cast back into the output data type.

# 2-D IDCT

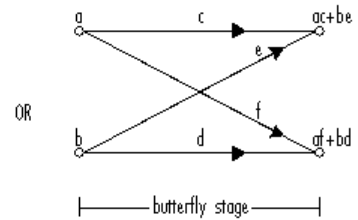
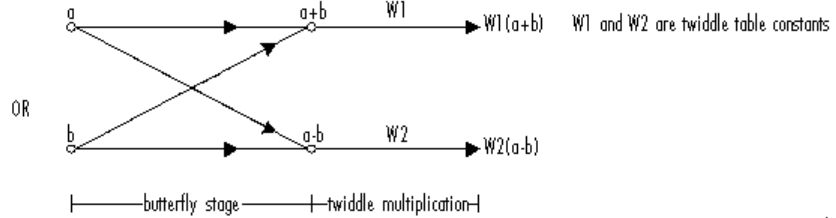
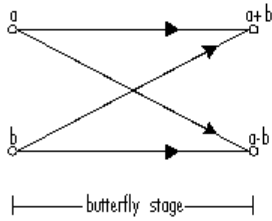

## Butterfly Stage Data Types

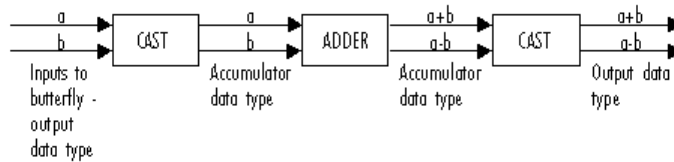

## Twiddle Multiplication Data Types

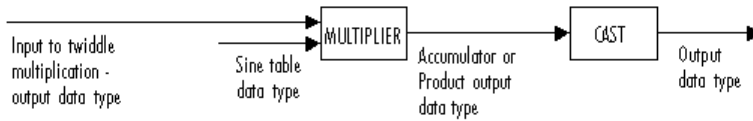

The output of the multiplier is in the product output data type when at least one of the inputs to the multiplier is real. When both of the inputs to the multiplier are complex, the result of the multiplication is in the accumulator data type. For details on the complex multiplication performed, refer to "Multiplication Data Types" in the Signal Processing Blockset documentation. You can set the sine table, product output, accumulator, and output data types in the block mask as discussed below.

## Dialog Box

The **Main** pane of the 2-D IDCT block dialog appears as follows:

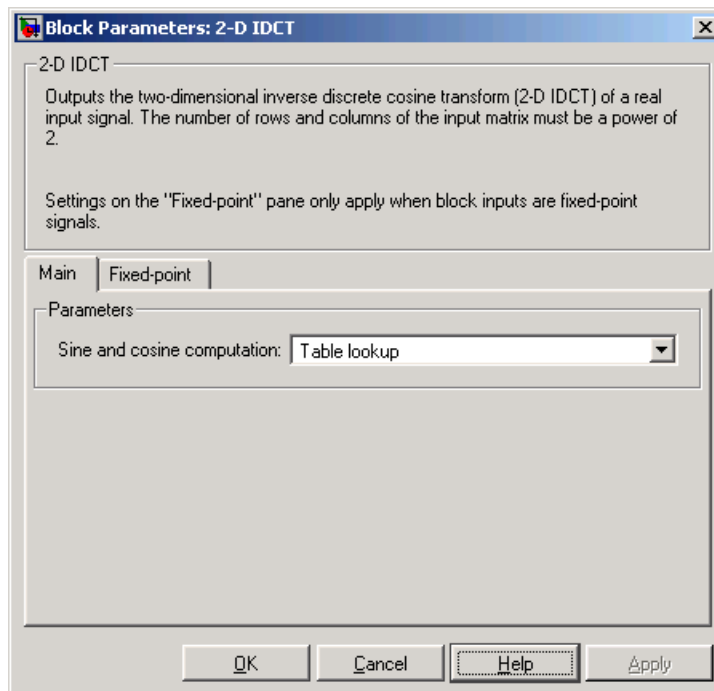

### Sine and cosine computation

Specify how the block computes the sine and cosine terms in the IDCT algorithm. If you select Trigonometric fcn, the block

## 2-D IDCT

computes the sine and cosine values during the simulation. If you select Table lookup, the block computes and stores the trigonometric values before the simulation starts. In this case, the block requires extra memory.

The **Fixed-point** pane of the 2-D IDCT block dialog appears as follows:

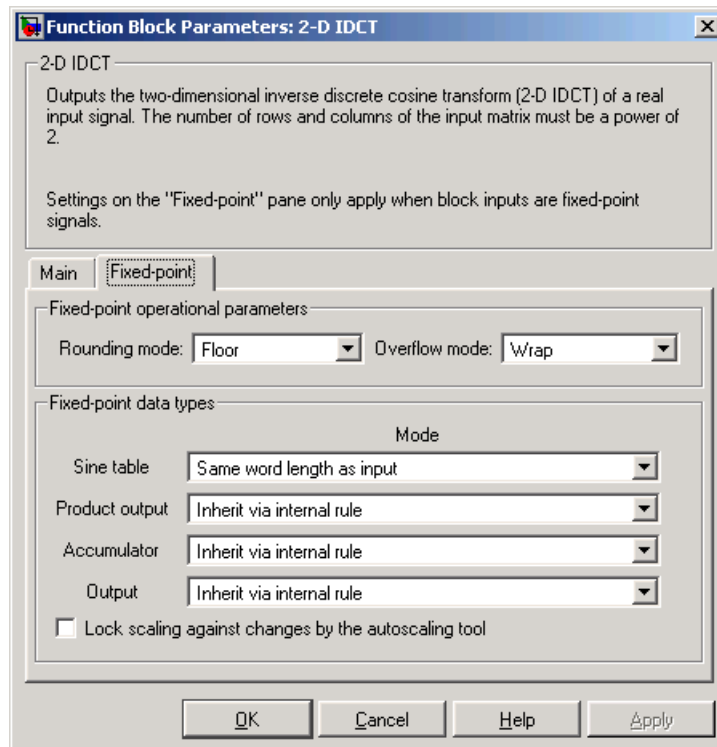

### Rounding mode

Select the rounding mode for fixed-point operations. The sine table values do not obey this parameter; they are always saturated and rounded to Nearest.

**Overflow mode**

Select the overflow mode for fixed-point operations. The sine table values do not obey this parameter; they are always saturated and rounded to Nearest.

**Sine table**

Choose how you will specify the word length of the values of the sine table. The fraction length of the sine table values is always equal to the word length minus one:

- When you select Same word length as input, the word length of the sine table values will match that of the input to the block.
- When you select Binary point scaling, you can enter the word length of the sine table values, in bits.
- When you select Slope and bias scaling, you can enter the word length of the sine table values, in bits.

The sine table values do not obey the **Rounding mode** and **Overflow mode** parameters; they are always saturated and rounded to Nearest.

**Product output**

Use this parameter to specify how you would like to designate the product output word and fraction lengths. Refer to "Fixed-Point Data Types" on page 9-73 and "Multiplication Data Types" in the Signal Processing Blockset documentation for illustrations depicting the use of the product output data type in this block:

- When you select Inherit via internal rule, the product output word length and fraction length are automatically set according to the following equations:

$$\textit{ideal product output word length} = \textit{output word length} + \textit{sine table values word length}$$

$$\textit{ideal product output fraction length} = \textit{output fraction length} + \textit{sine table values fraction length}$$

- When you select `Same as input`, these characteristics will match those of the input to the block.
- When you select `Binary point scaling`, you can enter the word length and the fraction length of the product output, in bits.
- When you select `Slope and bias scaling`, you can enter the word length, in bits, and the slope of the product output. The bias of all signals in the Video and Image Processing Blockset is zero.

### Accumulator

Use this parameter to specify how you would like to designate the accumulator word and fraction lengths. Refer to “Fixed-Point Data Types” on page 9-73 and “Multiplication Data Types” in the Signal Processing Blockset documentation for illustrations depicting the use of the accumulator data type in this block:

- When you select `Inherit via internal rule`, the accumulator word length and fraction length are automatically set according to the following equations:

$$\textit{ideal accumulator word length} = \textit{product output word length} + 1$$

$$\textit{ideal accumulator fraction length} = \textit{product output fraction length}$$

- When you select `Same as product output`, these characteristics will match those of the product output.
- When you select `Same as input`, these characteristics will match those of the input to the block.
- When you select `Binary point scaling`, you can enter the word length and the fraction length of the accumulator, in bits.
- When you select `Slope and bias scaling`, you can enter the word length, in bits, and the slope of the accumulator. The bias of all signals in the Video and Image Processing Blockset is zero.



## Output

Choose how you will specify the output word length and fraction length:

- When you select `Inherit` via `internal` rule, the output word length and fraction length are automatically set according to the following equations, where the input matrix is M-by-N:

If  $M > 1$  and  $N > 1$ ,  $output\ word\ length = input\ word\ length + \text{floor}(\log_2((M-1)(N-1))) + 1$

If  $M > 1$  and  $N = 1$ ,  $output\ word\ length = input\ word\ length + \text{floor}(\log_2(M-1)) + 1$

If  $M = 1$  and  $N > 1$ ,  $output\ word\ length = input\ word\ length + \text{floor}(\log_2(N-1)) + 1$

$output\ fraction\ length = input\ fraction\ length$

- When you select `Same` as `input`, these characteristics will match those of the input to the block.
- When you select `Binary point scaling`, you can enter the word length and the fraction length of the output, in bits.
- When you select `Slope and bias scaling`, you can enter the word length, in bits, and the slope of the output. The bias of all signals in the Video and Image Processing Blockset is zero.

### Lock scaling against changes by the autoscaling tool

Select this parameter to prevent any fixed-point scaling you specify in this block mask from being overridden by the autoscaling tool in the Fixed-Point Settings interface. For more information about the autoscaling tool, refer to the Fixed-Point Settings Interface section of the Signal Processing Blockset User's Guide.

## References

Chen, W.H, C.H. Smith, and S.C. Fralick, "A fast computational algorithm for the discrete cosine transform," *IEEE Trans. Commun.*, vol. COM-25, pp. 1004-1009. 1977.

## 2-D IDCT

---

Wang, Z. "Fast algorithms for the discrete W transform and for the discrete Fourier transform," *IEEE Trans. Acoust., Speech, Signal Processing*, vol. ASSP-32, pp. 803-816, Aug. 1984.

### See Also

2-D DCT	Video and Image Processing Blockset
2-D FFT	Video and Image Processing Blockset
2-D IFFT	Video and Image Processing Blockset

**Purpose** Compute two-dimensional IFFT of input

**Library** Transforms

**Description**

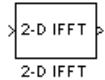

The 2-D IFFT block computes the inverse fast Fourier transform (IFFT) of an M-by-N input matrix in two steps. First it computes the one-dimensional IFFT along one dimension (row or column). Then it computes the IFFT of the output of the first step along the other dimension (column or row). The dimensions of the input matrix, M and N, must be powers of 2. To work with other input sizes, use the Zero Pad block to pad or truncate these dimensions to powers of two.

The output of the IFFT block is equivalent to the MATLAB `ifft2` function:

```
y = ifft(A)      % Equivalent MATLAB code
```

Computing the IFFT of each dimension of the input matrix is equivalent to calculating the two-dimensional inverse discrete Fourier transform (IDFT), which is defined by the following equation:

$$f(x, y) = \frac{1}{MN} \sum_{m=0}^{M-1} \sum_{n=0}^{N-1} F(m, n) e^{j \frac{2\pi mx}{M}} e^{j \frac{2\pi ny}{N}}$$

where  $0 \leq x \leq M - 1$  and  $0 \leq y \leq N - 1$ .

The output of this block has the same dimensions as the input.

## 2-D IFFT

Port	Input/Output	Supported Data Types	Supports Complex Values?
Input	Scalar, vector, or matrix of intensity values or a scalar, vector, or matrix that represents one plane of the RGB video stream	<ul style="list-style-type: none"><li>• Double-precision floating point</li><li>• Single-precision floating point</li><li>• Fixed point</li></ul>	Yes
Output	2-D IFFT of the input	Same as Input port	Yes

If the data type of the input signal is floating point, the data type of the output signal is the same floating-point data type. Otherwise, the output can be any fixed-point data type. This block supports a signal represented by a Simulink virtual bus.

### Optimizing the Table of Trigonometric Values

The block computes all the possible trigonometric values of the twiddle

factor,  $e^{j\frac{2\pi kx}{K}}$ , where  $K$  is the greater value of either  $M$  or  $N$  and  $k = 0, \dots, K - 1$ . The block stores these values in a table and retrieves them during simulation. You can optimize the table of trigonometric values for memory consumption or speed using the **Optimize table for** parameter. This parameter varies the number of table entries as summarized below.

<b>Optimize Table for Parameter Setting</b>	<b>Number of Table Entries for N-Point IFFT</b>
Speed	$3N/4$ – floating point $N$ – fixed point
Memory	$N/4$ – floating point Not supported for fixed point

### Input Order

You must select the **Input is in bit-reversed order** check box to designate whether the ordering of the column elements of the input is linear or bit-reversed order. If you select the **Input is in bit-reversed order** check box, the block assumes the input is in bit-reversed order. If you clear the **Input is in bit-reversed order** check box, block assumes the input is in linear order.

For more information ordering of the output, see "Linear and Bit-Reversed Output Order" in the Signal Processing Blockset User's Guide. Note that the 2-D FFT block bit-reverses the order of the columns as well as the rows.

### Conjugate Symmetric Input

The FFT block yields conjugate symmetric output when its input is real valued. Taking the IFFT of a conjugate symmetric input matrix produces real-valued output. Therefore, if the input to the block is both floating point and conjugate symmetric and you select the **Input is conjugate symmetric** check box, the block produces real-valued outputs. Selecting this check box optimizes the block's computation method.

If the IFFT block input is conjugate symmetric and you do not select the **Input is conjugate symmetric** check box, the IFFT block outputs a complex-valued signal with small imaginary parts. The block output is invalid if you select this check box and the input is not conjugate symmetric.

## 2-D IFFT

---

Note that the **Input is conjugate symmetric** parameter cannot be used for fixed-point signals.

### Scaled Output

By default, the **Skip scaling** check box is not selected. If your signal is a floating point signal, the block computes the scaled version of the IFFT. If your signal is a fixed-point signal, the output of each butterfly of the IFFT is divided by two. If you select the **Skip scaling** check box, the block computes the unscaled IFFT as defined by the following equation:

$$f(x, y) = \sum_{m=0}^{M-1} \sum_{n=0}^{N-1} F(m, n) e^{j \frac{2\pi m x}{M}} e^{j \frac{2\pi n y}{N}}$$

where  $0 \leq x \leq M - 1$  and  $0 \leq y \leq N - 1$ .

### Algorithms Used for IFFT Computation

Depending on whether the block input is floating point or fixed point, real or complex valued, and conjugate symmetric, the block uses one or more of the following algorithms as summarized in the following tables:

- Butterfly operation
- Double-signal algorithm
- Half-length algorithm
- Radix-2 decimation-in-time (DIT) algorithm
- Radix-2 decimation-in-frequency (DIF) algorithm

**For floating-point signals:**

Input Complexity	Other Parameter Settings	Algorithms Used for IFFT Computation
Real or complex	<input type="checkbox"/> Input is in bit-reversed order <input type="checkbox"/> Input is conjugate symmetric	Butterfly operation and radix-2 DIT
Real or complex	<input checked="" type="checkbox"/> Input is in bit-reversed order <input type="checkbox"/> Input is conjugate symmetric	Radix-2 DIF
Real or complex	<input type="checkbox"/> Input is in bit-reversed order <input checked="" type="checkbox"/> Input is conjugate symmetric	Butterfly operation and radix-2 DIT in conjunction with the half-length and double-signal algorithms
Real or complex	<input checked="" type="checkbox"/> Input is in bit-reversed order <input checked="" type="checkbox"/> Input is conjugate symmetric	Radix-2 DIF in conjunction with the half-length and double-signal algorithms

**For fixed-point signals:**

Input Complexity	Other Parameter Settings	Algorithms Used for IFFT Computation
Real or complex	<input type="checkbox"/> Input is in bit-reversed order <input type="checkbox"/> Input is conjugate symmetric	Butterfly operation and radix-2 DIT
Real or complex	<input checked="" type="checkbox"/> Input is in bit-reversed order <input type="checkbox"/> Input is conjugate symmetric	Radix-2 DIF

Note that the **Input is conjugate symmetric** parameter cannot be used for fixed-point signals.

**Fixed-Point Data Types**

The diagrams below show the data types used within the IFFT block for fixed-point signals. You can set the sine table, accumulator, product output, and output data types displayed in the diagrams in the IFFT block dialog as discussed in “Dialog Box” on page 9-88.

## 2-D IFFT

---

Inputs to the IFFT block are first cast to the output data type and stored in the output buffer. Each butterfly stage then processes signals in the accumulator data type, with the final output of the butterfly being cast back into the output data type. A twiddle factor is multiplied in before each butterfly stage in a decimation-in-time IFFT, and after each butterfly stage in a decimation-in-frequency IFFT.



**Decimation-in-time IFFT**

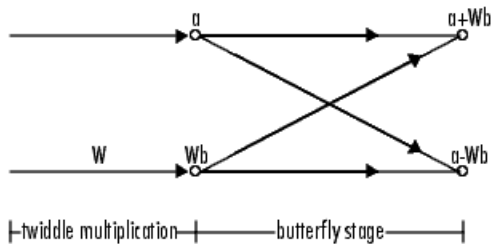

**Decimation-in-frequency IFFT**

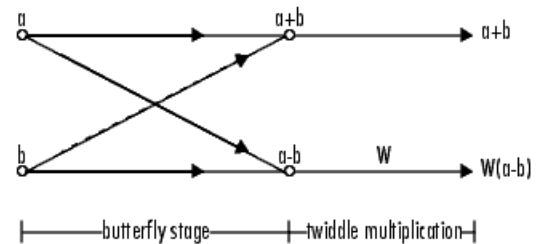

**Butterfly stage data types**

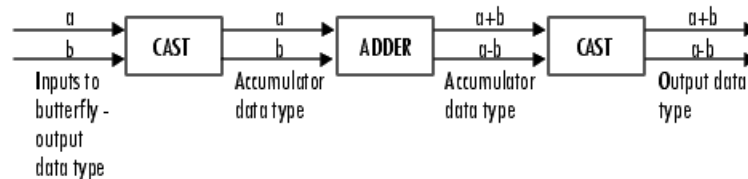

**Twiddle multiplication data types**



The output of the multiplier is in the accumulator data type since both of the inputs to the multiplier are complex. For details on the complex multiplication performed, refer to "Multiplication Data Types" in the Signal Processing Blockset documentation.

## 2-D IFFT

### Dialog Box

The **Main** pane of the IFFT block dialog appears as follows:

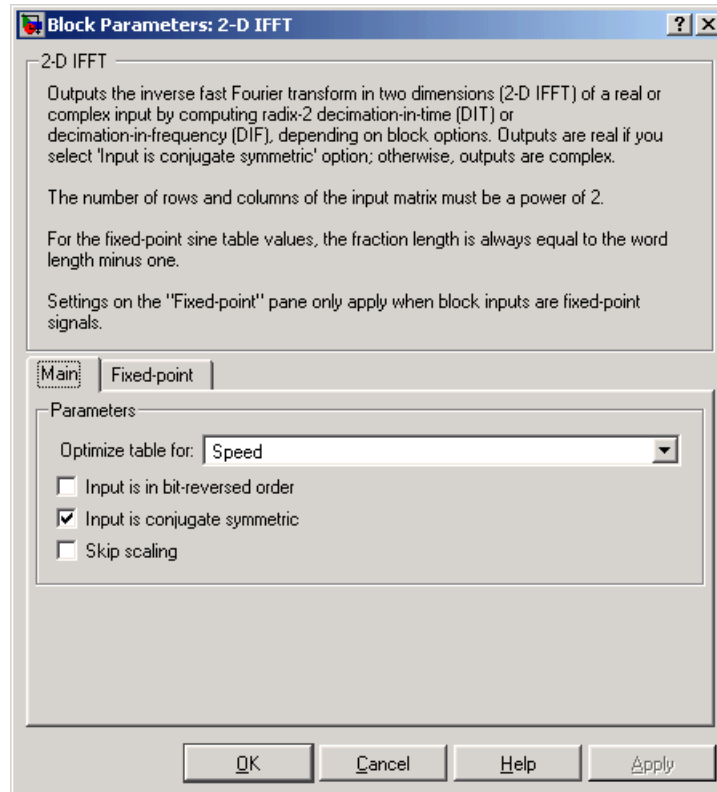

#### Optimize table for:

Select the optimization of the table of trigonometric values for Speed or Memory. This parameter must be set to Speed for fixed-point signals.

#### Input is in bit-reversed order

Designate the order of the input channel elements. Select when the input is in bit-reversed order, and clear when the input is in

linear order. The block yields invalid outputs when you do not set this parameter correctly. See “Input Order” on page 9-83.

### **Input is conjugate symmetric**

Select when the input to the block is both floating point and conjugate symmetric, and you want real-valued outputs. The block output is invalid when you set this parameter when the input is not conjugate symmetric. This parameter cannot be used for fixed-point signals.

### **Skip scaling**

When you select this check box, no scaling occurs. When this parameter is unselected, scaling does occur:

- For floating-point signals, rather than computing the IDFT, the block computes a scaled version of the IDFT. This scaled version of the IDFT does not include the multiplication factor of  $1/M$ .
- For fixed-point signals, the output of each butterfly of the IFFT is divided by two.

## 2-D IFFT

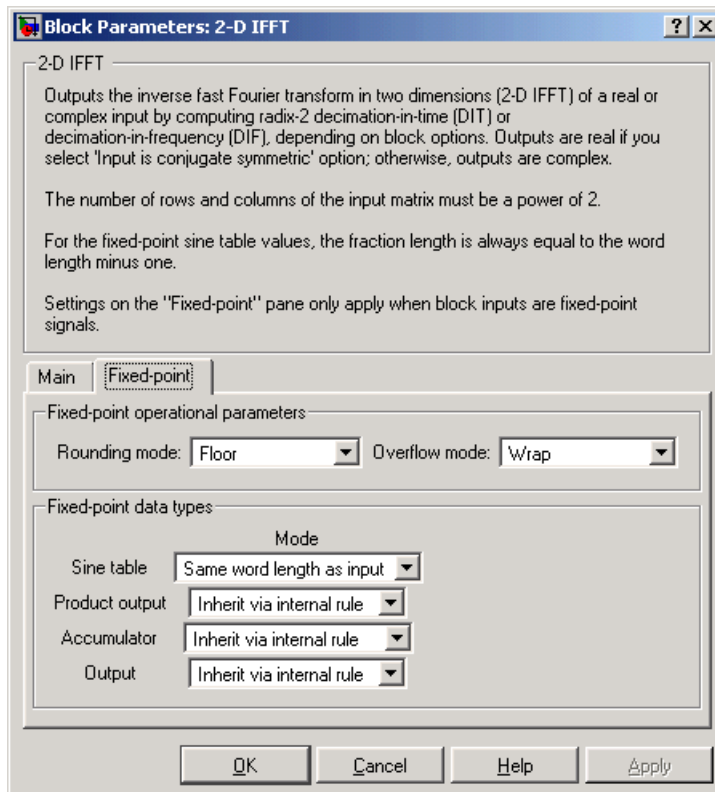

### **Rounding mode**

Select the rounding mode for fixed-point operations. The sine table values do not obey this parameter; they always round to Nearest.

### **Overflow mode**

Select the overflow mode for fixed-point operations. The sine table values do not obey this parameter; they are always saturated.

### **Sine table**

Choose how you will specify the word length of the values of the sine table. The fraction length of the sine table values is always equal to the word length minus one:

- When you select Same word length as input, the word length of the sine table values will match that of the input to the block.
- When you select Binary point scaling, you can enter the word length of the sine table values, in bits.
- When you select Slope and bias scaling, you can enter the word length of the sine table values, in bits.

The sine table values do not obey the **Rounding mode** and **Overflow mode** parameters; they are always saturated and rounded to Nearest.

### Product output

Use this parameter to specify how you would like to designate the product output word and fraction lengths. Refer to “Fixed-Point Data Types” on page 9-85 and "Multiplication Data Types" in the Signal Processing Blockset documentation for illustrations depicting the use of the product output data type in this block:

- When you select Inherit via internal rule, the product output word length and fraction length are automatically set according to the following equations:

$$\textit{ideal product output word length} = \textit{output word length} + \textit{sine table values word length}$$

$$\textit{ideal product output fraction length} = \textit{output fraction length} + \textit{sine table values fraction length}$$

- When you select Same as input, these characteristics will match those of the input to the block.
- When you select Binary point scaling, you can enter the word length and the fraction length of the product output, in bits.
- When you select Slope and bias scaling, you can enter the word length, in bits, and the slope of the product output. The bias of all signals in the Signal Processing Blockset is zero.

### Accumulator

Use this parameter to specify how you would like to designate the accumulator word and fraction lengths. Refer to “Fixed-Point Data Types” on page 9-85 and "Multiplication Data Types" in the Signal Processing Blockset documentation for illustrations depicting the use of the accumulator data type in this block:

- When you select `Inherit` via internal rule, the accumulator word length and fraction length are automatically set according to the following equations:

$$\textit{ideal accumulator word length} = \textit{product output word length} + 1$$

$$\textit{ideal accumulator fraction length} = \textit{product output fraction length}$$

- When you select `Same` as product output, these characteristics will match those of the product output.
- When you select `Same` as input, these characteristics will match those of the input to the block.
- When you select `Binary point scaling`, you can enter the word length and the fraction length of the accumulator, in bits.
- When you select `Slope and bias scaling`, you can enter the word length, in bits, and the slope of the accumulator. The bias of all signals in the Signal Processing Blockset is zero.

### Output

Choose how you will specify the output word length and fraction length:

- When you select `Inherit` via internal rule, the output word length and fraction length are automatically set according to the following equations, where the input matrix is M-by-N:

$$\textit{If } M > 1 \textit{ and } N > 1, \textit{ output word length} = \textit{input word length} + \textit{floor}(\log_2((M-1)(N-1)))+1$$

$$\textit{If } M > 1 \textit{ and } N = 1, \textit{ output word length} = \textit{input word length} + \textit{floor}(\log_2(M-1))+1$$

If  $M=1$  and  $N>1$ , *output word length* = *input word length* +  $\text{floor}(\log_2(N-1))+1$

*output fraction length* = *input fraction length*

- When you select **Same** as input, these characteristics will match those of the input to the block.
- When you select **Binary point scaling**, you can enter the word length and the fraction length of the output, in bits.
- When you select **Slope and bias scaling**, you can enter the word length, in bits, and the slope of the output. The bias of all signals in the Signal Processing Blockset is zero.

### See Also

2-D DCT	Video and Image Processing Blockset
2-D FFT	Video and Image Processing Blockset
2-D IDCT	Video and Image Processing Blockset
FFT	Signal Processing Blockset
IFFT	Signal Processing Blockset
Zero Pad	Signal Processing Blockset
bitrevorder	Signal Processing Toolbox
fft	Signal Processing Toolbox
ifft	Signal Processing Toolbox

## 2-D Maximum

**Purpose** Find maximum value in each input matrix

**Library** Statistics

**Description** The 2-D Maximum block identifies the value and/or position of the largest element in each input matrix or in a sequence of inputs over a period of time. Use the **Mode** parameter to specify the block's behavior.

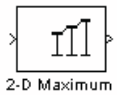

Port	Input/Output	Supported Data Types	Supports Complex Values?
Input	Scalar, vector, or matrix of intensity values or scalar, vector, or matrix that represents one plane of the input RGB video stream	<ul style="list-style-type: none"> <li>• Double-precision floating point</li> <li>• Single-precision floating point</li> <li>• Fixed point – Signed and unsigned real fixed point, and signed complex fixed point</li> <li>• Boolean – The block accepts Boolean inputs to the Rst port.</li> <li>• 32-bit unsigned integer – When inputs to the block are double-precision values, the index values are double-precision values. Otherwise, the index values are 32-bit unsigned integer values.</li> </ul>	Yes



Port	Input/Output	Supported Data Types	Supports Complex Values?
Val	Maximum value in each M-by-N input matrix	Same as Input port	Yes
Idx	Two-element vector of the form [row index column index] that represents the zero-based location of the maximum value	Same as Input port	No

Length-M 1-D vector inputs are treated as M-by-1 column vectors.

### Value Mode

When **Mode** is set to Value, the block computes the maximum value in each M-by-N input matrix and outputs this value at the Val port.

For complex inputs, the block selects the value in each matrix that has the maximum magnitude squared as shown below. For complex value  $u = a + bi$ , the magnitude squared is  $a^2 + b^2$ .

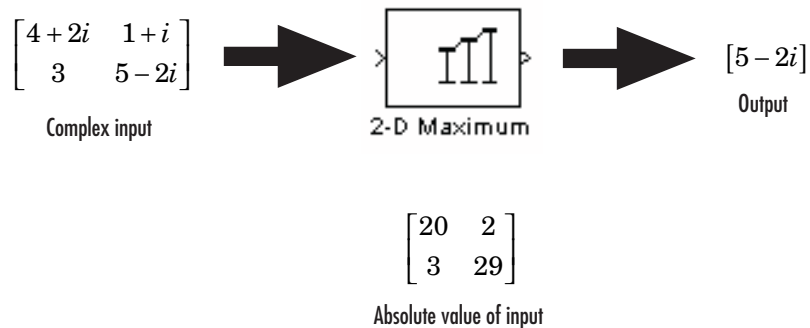

## 2-D Maximum

---

### Index Mode

When **Mode** is set to **Index**, the block computes the maximum value in each M-by-N input matrix and outputs the zero-based location of this value as a two-element vector of the form [row index column index] at the **Idx** port. When inputs to the block are double-precision values, the index values are double-precision values. Otherwise, the index values are 32-bit unsigned integer values.

If a maximum value occurs more than once in one matrix, the index corresponds to the first occurrence, where the block scans down the columns. For example, if the input matrix is

$$\begin{bmatrix} 2 & 13 \\ 13 & 9 \end{bmatrix}$$

the block outputs [1 0] at the **Idx** port.

### Value and Index Mode

When **Mode** is set to **Value** and **Index**, the block outputs the maximum value in each M-by-N input matrix at the **Val** port and the zero-based locations of these values at the **Idx** port. When the input values are double-precision floating point, the equivalent MATLAB code is [val, Idx] = max(u(:)), where u is the input matrix.

### Running Mode

When **Mode** is set to **Running**, the block identifies the maximum value in a series of M-by-N inputs.

For example, suppose A is the first input to the block and B is the second and current input to the block, where

$$A = \begin{bmatrix} 1 & 3 \\ 2 & 4 \end{bmatrix}$$

and

$$B = \begin{bmatrix} 5 & 6 \\ 7 & 3 \end{bmatrix}$$

.

The block computes the maximum value corresponding to each element,

$$\begin{bmatrix} \max([1,5]) & \max([3,6]) \\ \max([2,7]) & \max([4,3]) \end{bmatrix}$$

and outputs

$$\begin{bmatrix} 5 & 6 \\ 7 & 4 \end{bmatrix}$$

For the next input, the block identifies the maximum for each element of the first three inputs, and so on.

### Resetting the Running Maximum

The block resets the running maximum whenever a reset event is detected at the optional Rst port. The rate of the reset signal must be a positive integer multiple of the rate of the data signal input.

When the block is reset, the running maximum associated with each element is initialized to the value in the corresponding location of the current input.

You specify the reset event in the **Reset port** menu:

- None – disables the Rst port.
- Rising edge – Triggers a reset operation when the Rst input does one of the following:
  - Rises from a negative value to a positive value or zero
  - Rises from zero to a positive value, where the rise is not a continuation of a rise from a negative value to zero (see the following figure)

## 2-D Maximum

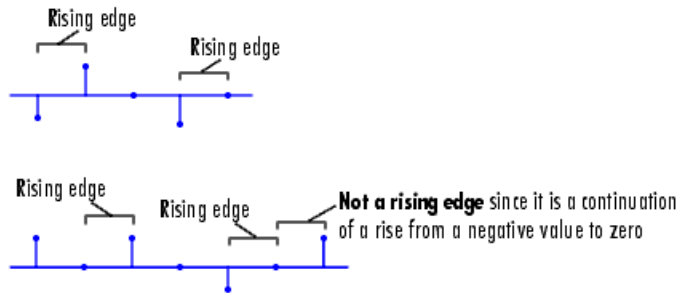

- Falling edge – Triggers a reset operation when the Rst input does one of the following:
  - Falls from a positive value to a negative value or zero
  - Falls from zero to a negative value, where the fall is not a continuation of a fall from a positive value to zero (see the following figure)

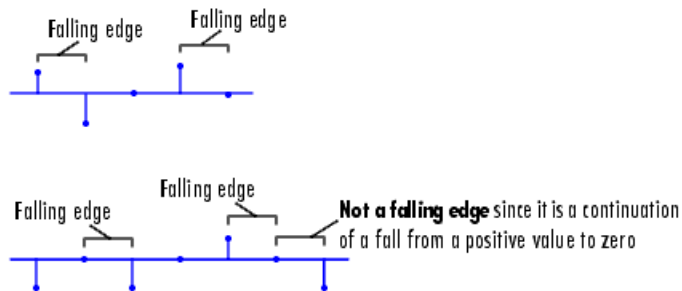

- Either edge – Triggers a reset operation when the Rst input is a Rising edge or Falling edge (as described above)
- Non-zero sample – Triggers a reset operation at each sample time that the Rst input is not zero

---

**Note** When running simulations in the Simulink `MultiTasking` mode, reset signals have a one-sample latency. Therefore, when the block detects a reset event, there is a one-sample delay at the reset port rate before the block applies the reset. For more information on latency and the Simulink tasking modes, see "The Configuration Parameters Dialog Box" in the Simulink documentation.

---

### Fixed-Point Data Types

The parameters on the **Fixed-point** pane of the block dialog are only used for complex fixed-point inputs. The sum of the squares of the real and imaginary parts of such an input are formed before a comparison is made, as described in "Value Mode" on page 9-95. The results of the squares of the real and imaginary parts are placed into the product output data type. The result of the sum of the squares is placed into the accumulator data type. These parameters are ignored for other types of inputs.

## 2-D Maximum

### Dialog Box

The **Main** pane of the 2-D Maximum block dialog appears as follows:

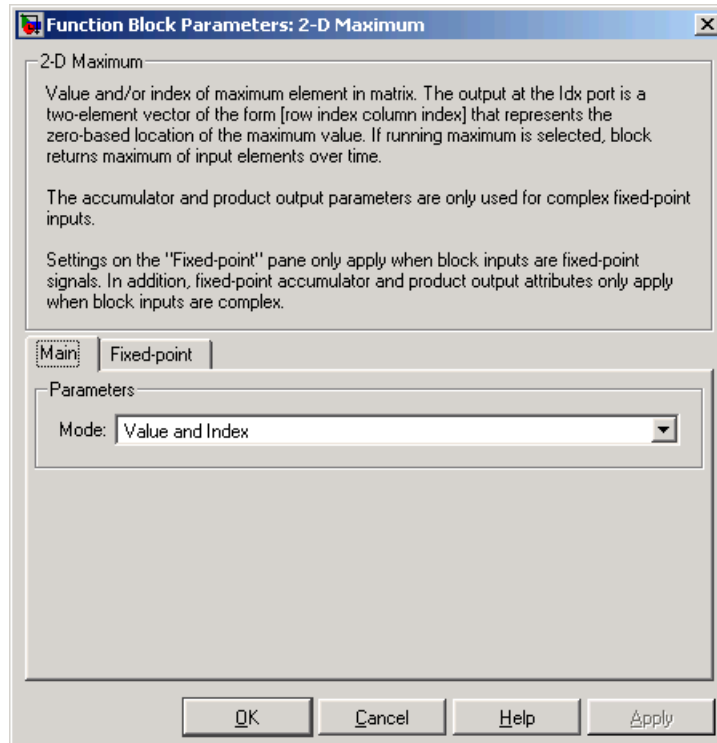

### Mode

Specify the block's mode of operation:

- Value – Output the maximum value of each input matrix
- Index – Output the zero-based index location of the maximum value
- Value and Index – Output both the value and the index location

- Running – Track the maximum value of the input sequence over time

### Reset port

Specify the reset event detected at the Rst input port when you select Running for the **Mode** parameter. The rate of the reset signal must be a positive integer multiple of the rate of the data signal input. This parameter is only visible if, for the **Mode** parameter, you select Running.

The **Fixed-point** pane of the 2-D Maximum block dialog appears as follows:

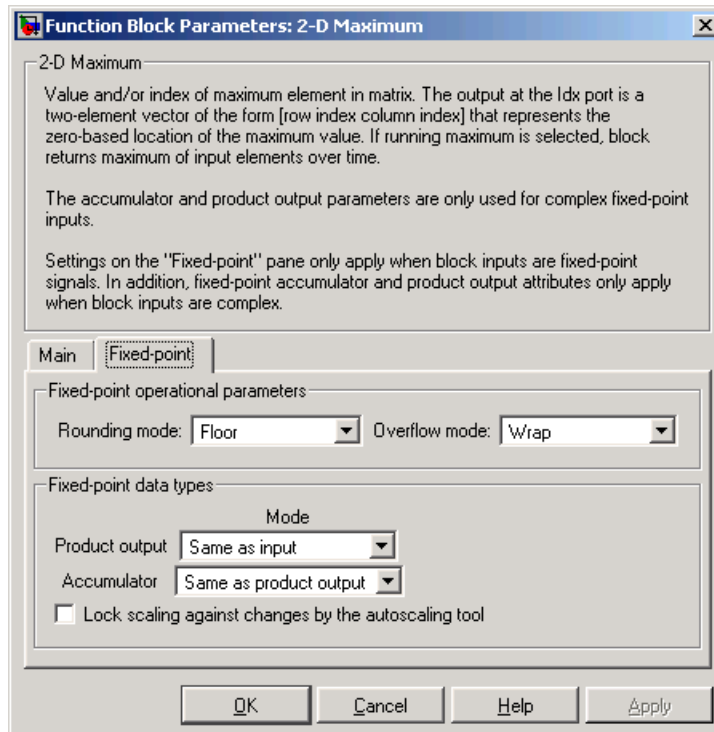

## 2-D Maximum

---

---

**Note** The parameters on the **Fixed-point** pane are only used for complex fixed-point inputs. The sum of the squares of the real and imaginary parts of such an input are formed before a comparison is made, as described in “Value Mode” on page 9-95. The results of the squares of the real and imaginary parts are placed into the product output data type. The result of the sum of the squares is placed into the accumulator data type. These parameters are ignored for other types of inputs.

---

### **Rounding mode**

Select the rounding mode for fixed-point operations.

### **Overflow mode**

Select the overflow mode for fixed-point operations.

### **Product output**

Use this parameter to specify how you would like to designate the product output word and fraction lengths resulting from a complex-complex multiplication in the block. Refer to "Multiplication Data Types" in the Signal Processing Blockset documentation for more information:

- When you select `Same as input`, these characteristics will match those of the input to the block.
- When you select `Binary point scaling`, you can enter the word length and the fraction length of the product output, in bits.
- When you select `Slope and bias scaling`, you can enter the word length, in bits, and the slope of the product output. This block requires power-of-two slope and a bias of zero.

### **Accumulator**

Use this parameter to specify the accumulator word and fraction lengths resulting from a complex-complex multiplication in the block. Refer to "Multiplication Data Types" in the Signal Processing Blockset documentation for more information:



- When you select Same as product output, these characteristics will match those of the product output.
- When you select Same as input, these characteristics will match those of the input to the block.
- When you select Binary point scaling, you can enter the word length and the fraction length of the accumulator, in bits.
- When you select Slope and bias scaling, you can enter the word length, in bits, and the slope of the accumulator. This block requires power-of-two slope and a bias of zero.

### **Lock scaling against changes by the autoscaling tool**

Select this parameter to prevent any fixed-point scaling you specify in this block mask from being overridden by the autoscaling tool in the Fixed-Point Settings interface. For more information about the autoscaling tool, refer to the Fixed-Point Settings Interface section of the Signal Processing Blockset User's Guide.

### **See Also**

2-D Autocorrelation	Video and Image Processing Blockset
2-D Correlation	Video and Image Processing Blockset
2-D Histogram	Video and Image Processing Blockset
2-D Mean	Video and Image Processing Blockset
2-D Median	Video and Image Processing Blockset
2-D Minimum	Video and Image Processing Blockset
2-D Standard Deviation	Video and Image Processing Blockset
2-D Variance	Video and Image Processing Blockset
Maximum	Signal Processing Blockset
max	MATLAB

## 2-D Mean

**Purpose** Find mean value of each input matrix

**Library** Statistics

**Description** The 2-D Mean block computes the mean of each input matrix or the mean value in a sequence of inputs over a period of time. Use the **Running mean** check box to choose between the block's basic and running operation.

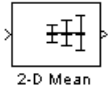

Port	Input/Output	Supported Data Types	Supports Complex Values?
Input	Scalar, vector, or matrix of intensity values or scalar, vector, or matrix that represents one plane of the input RGB video stream	<ul style="list-style-type: none"><li>• Double-precision floating point</li><li>• Single-precision floating point</li><li>• Fixed point (signed only)</li><li>• Boolean – The block accepts Boolean inputs to the Rst port</li><li>• 8-, 16-, and 32-bit signed integers</li></ul>	Yes
Output	Mean of each M-by-N input matrix or the mean for each element of a series of M-by-N inputs	<ul style="list-style-type: none"><li>• Double-precision floating point</li><li>• Single-precision floating point</li><li>• Fixed point (signed only)</li><li>• 8-, 16-, and 32-bit signed integers</li></ul>	Yes

Length-M 1-D vector inputs are treated as M-by-1 column vectors.

## Basic Operation

When you clear the **Running mean** check box, the block computes the mean of each M-by-N input matrix and outputs it from the block. The equivalent MATLAB code is `mean(u(:))`, where `u` is the input matrix.

The mean of a complex input is computed independently for the real and imaginary components, as shown below.

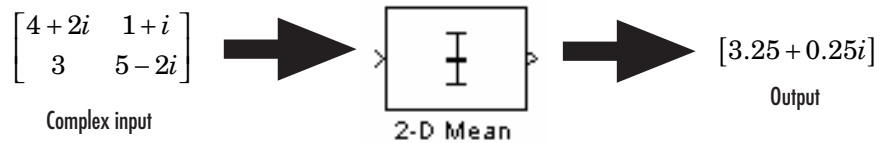

## Running Operation

When you select the **Running mean** check box, the block computes the mean for each element of a series of M-by-N inputs.

For example, suppose `A` is the first input to the block and `B` is the second and current input to the block, where

$$A = \begin{bmatrix} 1 & 3 \\ 2 & 4 \end{bmatrix}$$

and

$$B = \begin{bmatrix} 5 & 7 \\ 6 & 8 \end{bmatrix}$$

The block computes the mean corresponding to each element,

$$\begin{bmatrix} \text{mean}([1,5]) & \text{mean}([3,7]) \\ \text{mean}([2,6]) & \text{mean}([4,8]) \end{bmatrix}$$

and outputs

## 2-D Mean

---

$$\begin{bmatrix} 3 & 5 \\ 4 & 6 \end{bmatrix}$$

For the next input, the block computes the mean for each element of the first three inputs, and so on.

### Resetting the Running Mean

The block resets the running mean whenever a reset event is detected at the optional Rst port. The rate of the reset signal must be a positive integer multiple of the rate of the data signal input.

When the block is reset, the running mean associated with each element is initialized to the value in the corresponding location of the current input.

You specify the reset event by the **Reset port** parameter:

- None disables the Rst port.
- Rising edge – Triggers a reset operation when the Rst input does one of the following:
  - Rises from a negative value to a positive value or zero
  - Rises from zero to a positive value, where the rise is not a continuation of a rise from a negative value to zero (see the following figure)

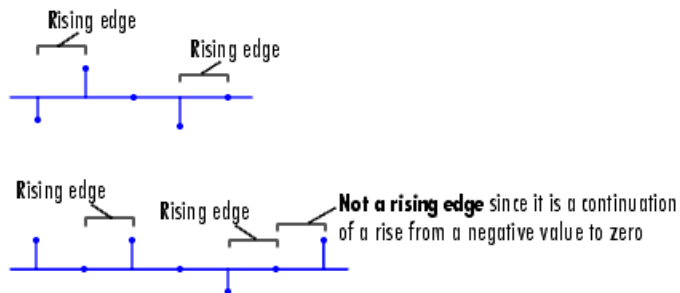

- Falling edge – Triggers a reset operation when the Rst input does one of the following:
  - Falls from a positive value to a negative value or zero
  - Falls from zero to a negative value, where the fall is not a continuation of a fall from a positive value to zero (see the following figure)

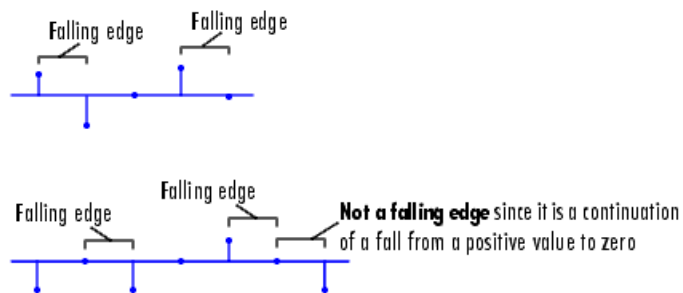

- Either edge – Triggers a reset operation when the Rst input is a Rising edge or Falling edge (as described above)
- Non-zero sample – Triggers a reset operation at each sample time that the Rst input is not zero

---

**Note** When running simulations in the Simulink MultiTasking mode, reset signals have a one-sample latency. Therefore, when the block detects a reset event, there is a one-sample delay at the reset port rate before the block applies the reset. For more information on latency and the Simulink tasking modes, see "The Configuration Parameters Dialog Box" in the Simulink documentation.

---

### Fixed-Point Data Types

The following diagram shows the data types used within the 2-D Mean block for fixed-point signals.

# 2-D Mean

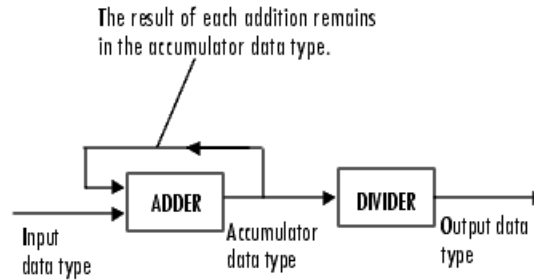

You can set the accumulator and output data types in the block dialog box.

## Dialog Box

The **Main** pane of the 2-D Mean block dialog appears as follows.

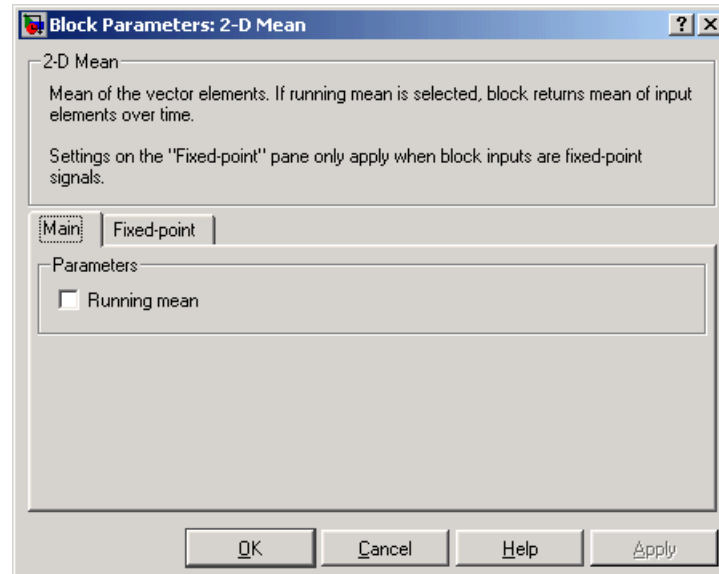

## Running mean

Select this check box to enable the block's running operation.

## Reset port

Determines the reset event that causes the block to reset the running mean. The rate of the reset signal must be a positive integer multiple of the rate of the data signal input. This parameter is visible only when you select the **Running mean** check box.

The **Fixed-point** pane of the 2-D Mean block dialog appears as follows:

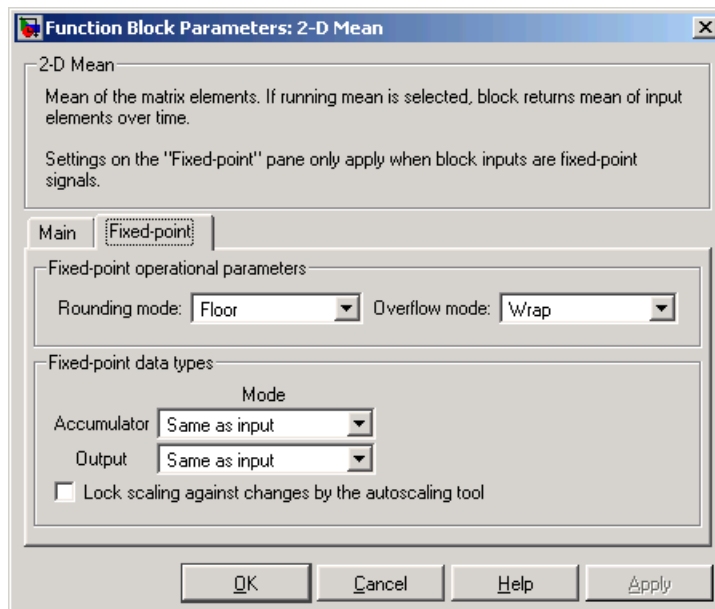

## Rounding mode

Select the rounding mode for fixed-point operations.

## Overflow mode

Select the overflow mode for fixed-point operations.

## 2-D Mean

---

### Accumulator

Use this parameter to specify the accumulator word and fraction lengths:

- When you select `Same as input`, these characteristics will match those of the input to the block.
- When you select `Binary point scaling`, you can enter the word length and the fraction length of the accumulator, in bits.
- When you select `Slope and bias scaling`, you can enter the word length, in bits, and the slope of the accumulator. This block requires power-of-two slope and a bias of zero.

### Output

Choose how you will specify the output word length and fraction length:

- When you select `Same as input`, these characteristics will match those of the input to the block.
- When you select `Binary point scaling`, you can enter the word length and the fraction length of the output, in bits.
- When you select `Slope and bias scaling`, you can enter the word length, in bits, and the slope of the output. This block requires power-of-two slope and a bias of zero.

### Lock scaling against changes by the autoscaling tool

Select this parameter to prevent any fixed-point scaling you specify in this block mask from being overridden by the autoscaling tool in the Fixed-Point Settings interface. For more information about the autoscaling tool, refer to the Fixed-Point Settings Interface section of the Signal Processing Blockset User's Guide.

### See Also

2-D Autocorrelation	Video and Image Processing Blockset
2-D Correlation	Video and Image Processing Blockset



2-D Histogram	Video and Image Processing Blockset
2-D Maximum	Video and Image Processing Blockset
2-D Median	Video and Image Processing Blockset
2-D Minimum	Video and Image Processing Blockset
2-D Standard Deviation	Video and Image Processing Blockset
2-D Variance	Video and Image Processing Blockset
Mean	Signal Processing Blockset
mean	MATLAB

## 2-D Median

**Purpose** Find median value of each input matrix

**Library** Statistics

**Description** The 2-D Median block outputs the median value of the M-by-N input matrix.

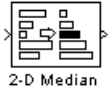

Port	Input/Output	Supported Data Types	Supports Complex Values?
Input	Scalar, vector, or matrix of intensity values or scalar, vector, or matrix that represents one plane of the input RGB video stream	<ul style="list-style-type: none"><li>• Double-precision floating point</li><li>• Single-precision floating point</li><li>• Fixed point</li><li>• 8-, 16-, 32-, and 128-bit signed integers</li><li>• 8-, 16-, 32-, and 128-bit unsigned integers</li></ul>	Yes
Output	Median value of each M-by-N input matrix	Same as Input port	Yes

Length-M 1-D vector inputs are treated as M-by-1 column vectors. This block supports a signal represented by a Simulink virtual bus.

When M is odd, the block sorts the column elements by value, and outputs the central row of the sorted matrix.

```
s = sort(u(:));  
y = s((M+1)/2)
```

When  $M$  is even, the block sorts the column elements by value, and outputs the average of the two central rows in the sorted matrix.

```
s = sort(u(:));
y = mean([s(M/2), s(M/2+1)])
```

Complex inputs are sorted by *magnitude squared*. For complex value  $u = a + bi$ , the magnitude squared is  $a^2 + b^2$ .

### Fixed-Point Data Types

For fixed-point inputs, you can specify accumulator, product output, and output data types as discussed in “Dialog Box” on page 9-114. Not all these fixed-point parameters are applicable for all types of fixed-point inputs. The following table shows when each kind of data type and scaling is used.

	Output data type	Accumulator data type	Product output data type
<b>Even <math>M</math></b>	X	X	
<b>Odd <math>M</math></b>	X		
<b>Odd <math>M</math> and complex</b>	X	X	X
<b>Even <math>M</math> and complex</b>	X	X	X

The accumulator and output data types and scalings are used for fixed-point signals when  $M$  is even. The result of the sum performed while calculating the average of the two central rows of the input matrix is stored in the accumulator data type and scaling. The total result of the average is then put into the output data type and scaling.

The accumulator and product output parameters are used for complex fixed-point inputs. The sum of the squares of the real and imaginary parts of such an input are formed before the input elements are sorted. The results of the squares of the real and imaginary parts are placed into the product output data type and scaling. The result of the sum of the squares is placed into the accumulator data type and scaling.

## 2-D Median

---

For fixed-point inputs that are both complex and have even  $M$ , the data types are used in all of the ways described. Therefore, in such cases the accumulator type is used in two different ways.

### Dialog Box

The **Main** pane of the 2-D Median block dialog appears as follows:

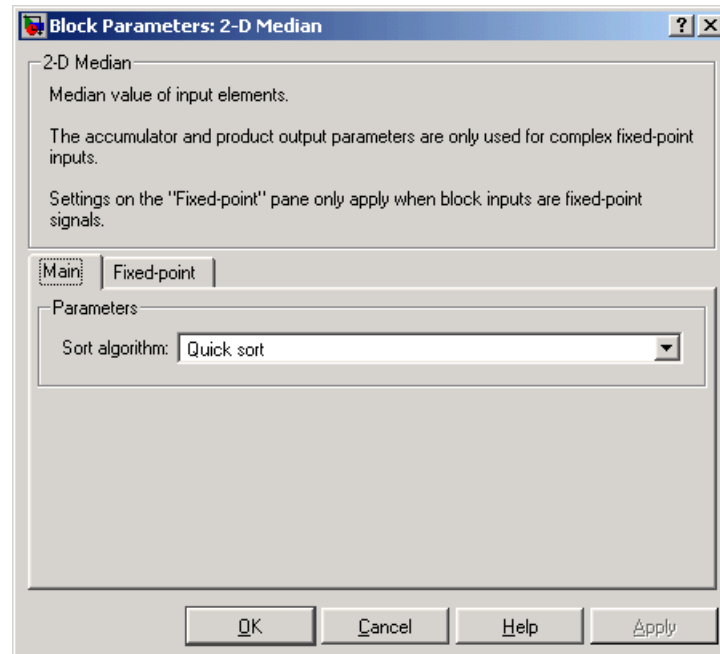

### Sort algorithm

Specify whether the elements of the input are sorted using a Quick sort or an Insertion sort algorithm.

The **Fixed-point** pane of the 2-D Median block dialog appears as follows:

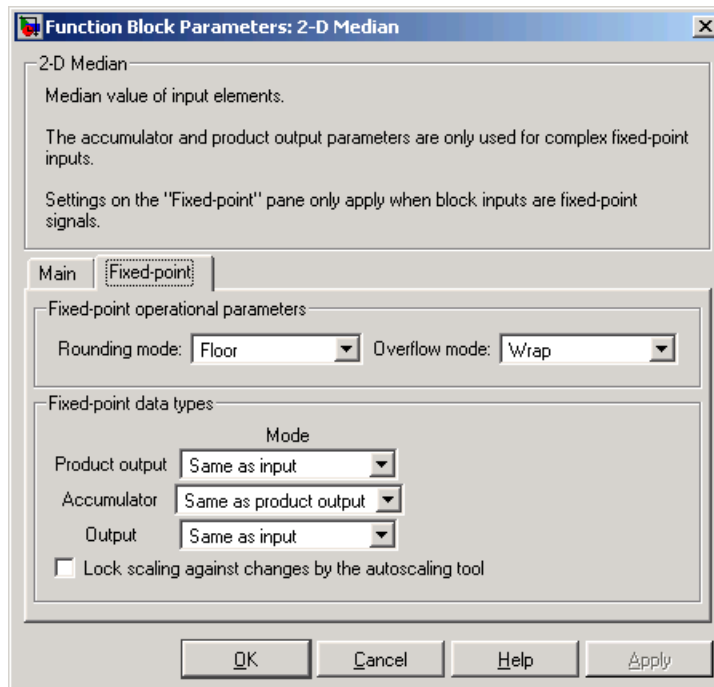

### **Rounding mode**

Select the rounding mode for fixed-point operations.

### **Overflow mode**

Select the overflow mode for fixed-point operations.

---

**Note** The product output, accumulator, and output parameters listed below are only used in certain cases. Refer to “Fixed-Point Data Types” on page 9-113 for more information.

---

### **Product output**

Use this parameter to specify how you would like to designate the product output word and fraction lengths:

## 2-D Median

---

- When you select `Same as input`, these characteristics will match those of the input to the block.
- When you select `Binary point scaling`, you can enter the word length and the fraction length of the product output, in bits.
- When you select `Slope and bias scaling`, you can enter the word length, in bits, and the slope of the product output. This block requires power-of-two slope and a bias of zero.

### Accumulator

Use this parameter to specify the accumulator word and fraction lengths resulting from a complex-complex multiplication in the block:

- When you select `Same as product output`, these characteristics will match those of the product output
- When you select `Same as input`, these characteristics will match those of the input to the block.
- When you select `Binary point scaling`, you can enter the word length and the fraction length of the accumulator, in bits.
- When you select `Slope and bias scaling`, you can enter the word length, in bits, and the slope of the accumulator. This block requires power-of-two slope and a bias of zero.

### Output

Choose how you will specify the output word length and fraction length:

- When you select `Same as input`, these characteristics will match those of the input to the block.
- When you select `Binary point scaling`, you can enter the word length and the fraction length of the output, in bits.
- When you select `Slope and bias scaling`, you can enter the word length, in bits, and the slope of the output. This block requires power-of-two slope and a bias of zero.

### Lock scaling against changes by the autoscaling tool

Select this parameter to prevent any fixed-point scaling you specify in this block mask from being overridden by the autoscaling tool in the Fixed-Point Settings interface. For more information about the autoscaling tool, refer to the Fixed-Point Settings Interface section of the Signal Processing Blockset User's Guide.

### See Also

2-D Autocorrelation	Video and Image Processing Blockset
2-D Correlation	Video and Image Processing Blockset
2-D Histogram	Video and Image Processing Blockset
2-D Maximum	Video and Image Processing Blockset
2-D Mean	Video and Image Processing Blockset
2-D Minimum	Video and Image Processing Blockset
2-D Standard Deviation	Video and Image Processing Blockset
2-D Variance	Video and Image Processing Blockset
Median	Signal Processing Blockset
median	MATLAB

## 2-D Minimum

**Purpose** Find minimum value of each input matrix

**Library** Statistics

**Description** The 2-D Minimum block identifies the value and/or position of the smallest element in each input matrix or in a sequence of inputs over a period of time. Use the **Mode** parameter to specify the block's behavior.

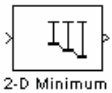
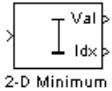

Port	Input/Output	Supported Data Types	Supports Complex Values?
Input	Scalar, vector, or matrix of intensity values or scalar, vector, or matrix that represents one plane of the input RGB video stream	<ul style="list-style-type: none"> <li>• Double-precision floating point</li> <li>• Single-precision floating point</li> <li>• Fixed point – Signed and unsigned real fixed point, and signed complex fixed point</li> <li>• Boolean – The block accepts Boolean inputs to the Rst port.</li> <li>• 32-bit unsigned integer – When inputs to the block are double-precision values, the index values are double-precision values. Otherwise, the index values are 32-bit unsigned integer values.</li> </ul>	Yes



Port	Input/Output	Supported Data Types	Supports Complex Values?
Val	Minimum value in each M-by-N input matrix	Same as Input port	Yes
Idx	Two-element vector of the form [row index column index] that represents the zero-based location of the minimum value	Same as Input port	No

Length-M 1-D vector inputs are treated as M-by-1 column vectors.

### Value Mode

When **Mode** is set to Value, the block computes the minimum value in each M-by-N input matrix and outputs this value at the Val port.

For complex inputs, the block selects the value in each matrix that has the minimum magnitude squared as shown below. For complex value  $u = a + bi$ , the magnitude squared is  $a^2 + b^2$ .

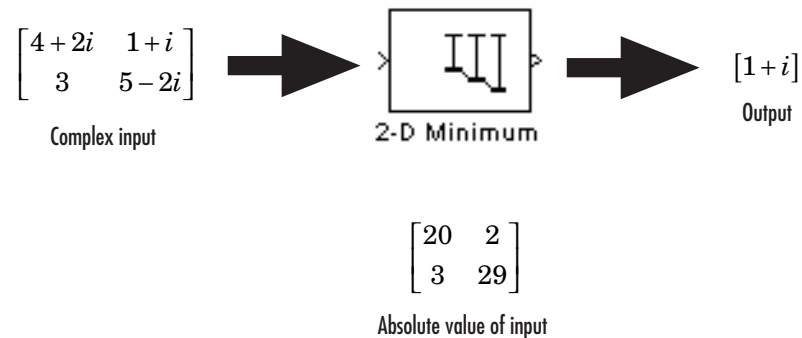

## 2-D Minimum

---

### Index Mode

When **Mode** is set to **Index**, the block computes the minimum value in each M-by-N input matrix and outputs the zero-based location of this value as a two-element vector of the form [row index column index] at the **Idx** port. When inputs to the block are double-precision values, the index values are double-precision values. Otherwise, the index values are 32-bit unsigned integer values.

If a minimum value occurs more than once in one matrix, the computed index corresponds to the first occurrence, where the block scans down the columns. For example, if the input matrix is

$$\begin{bmatrix} 3 & 9 \\ 7 & 3 \end{bmatrix}$$

the block outputs [0 0] at the **Idx** port.

### Value and Index Mode

When **Mode** is set to **Value** and **Index**, the block outputs the minimum value in each M-by-N input matrix at the **Val** port and the zero-based locations of these values at the **Idx** port. When the input values are double-precision floating point, the equivalent MATLAB code is [val, Idx] = min(u(:)), where u is the input matrix.

### Running Mode

When **Mode** is set to **Running**, the block identifies the minimum value in a series of M-by-N inputs.

For example, suppose A is the first input to the block and B is the second and current input to the block, where

$$A = \begin{bmatrix} 1 & 3 \\ 2 & 4 \end{bmatrix}$$

and

$$B = \begin{bmatrix} 5 & 6 \\ 7 & 3 \end{bmatrix}$$

The block computes the minimum value corresponding to each element,

$$\begin{bmatrix} \min([1,5]) & \min([3,6]) \\ \min([2,7]) & \min([4,3]) \end{bmatrix}$$

and outputs

$$\begin{bmatrix} 1 & 3 \\ 2 & 3 \end{bmatrix}$$

For the next input, the block identifies the minimum for each element of the first three inputs, and so on.

### Resetting the Running Minimum

The block resets the running minimum whenever a reset event is detected at the optional Rst port. The rate of the reset signal must be a positive integer multiple of the rate of the data signal input.

When the block is reset, the running minimum associated with each element is initialized to the value in the corresponding location of the current input.

To specify the reset event by the **Reset port** parameter:

- None disables the Rst port.
- Rising edge – Triggers a reset operation when the Rst input does one of the following:
  - Rises from a negative value to a positive value or zero
  - Rises from zero to a positive value, where the rise is not a continuation of a rise from a negative value to zero (see the following figure)

## 2-D Minimum

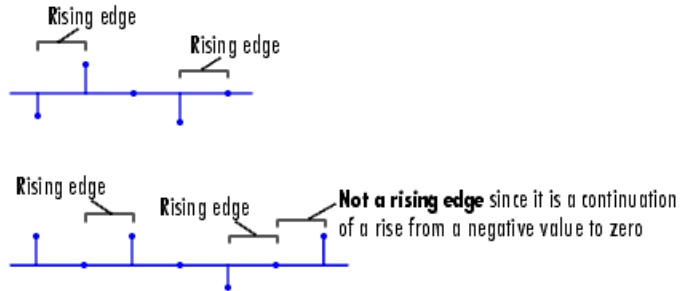

- Falling edge – Triggers a reset operation when the Rst input does one of the following:
  - Falls from a positive value to a negative value or zero
  - Falls from zero to a negative value, where the fall is not a continuation of a fall from a positive value to zero (see the following figure)

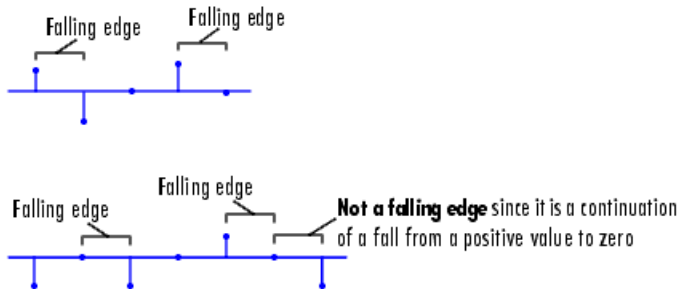

- Either edge – Triggers a reset operation when the Rst input is a Rising edge or Falling edge (as described above)
- Non-zero sample – Triggers a reset operation at each sample time that the Rst input is not zero

---

**Note** When running simulations in the Simulink `MultiTasking` mode, reset signals have a one-sample latency. Therefore, when the block detects a reset event, there is a one-sample delay at the reset port rate before the block applies the reset. For more information on latency and the Simulink tasking modes, see "The Configuration Parameters Dialog Box" in the Simulink documentation.

---

### Fixed-Point Data Types

The parameters on the **Fixed-point** pane of the block dialog are only used for complex fixed-point inputs. The sum of the squares of the real and imaginary parts of such an input are formed before a comparison is made, as described in "Value Mode" on page 9-119. The results of the squares of the real and imaginary parts are placed into the product output data type. The result of the sum of the squares is placed into the accumulator data type. These parameters are ignored for other types of inputs.

# 2-D Minimum

## Dialog Box

The **Main** pane of the 2-D Minimum block dialog appears as follows:

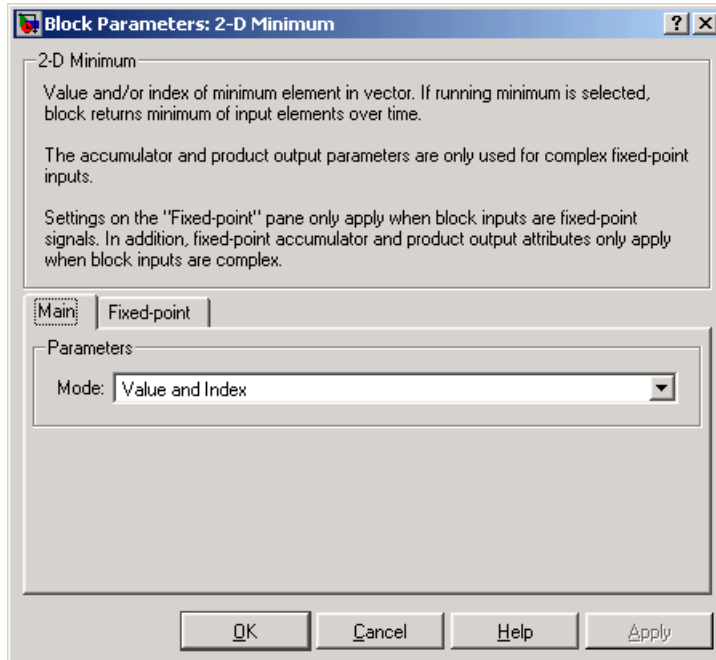

### Mode

Specify the block's mode of operation:

- Value – Output the minimum value of each input matrix
- Index – Output the zero-based index location of the minimum value
- Value and Index – Output both the value and the index location
- Running – Track the minimum value of the input sequence over time

## Reset port

Specify the reset event detected at the Rst input port when you select Running for the **Mode** parameter. The rate of the reset signal must be a positive integer multiple of the rate of the data signal input. This parameter is only visible if, for the **Mode** parameter, you select Running.

The **Fixed-point** pane of the 2-D Minimum block dialog appears as follows:

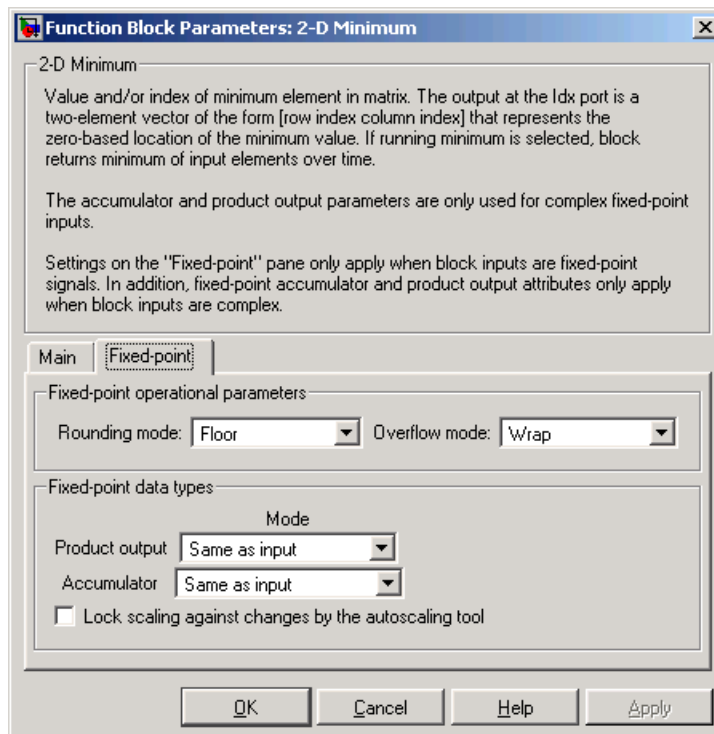

## 2-D Minimum

---

---

**Note** The parameters on the **Fixed-point** pane are only used for complex fixed-point inputs. The sum of the squares of the real and imaginary parts of such an input are formed before a comparison is made, as described in “Value Mode” on page 9-119. The results of the squares of the real and imaginary parts are placed into the product output data type. The result of the sum of the squares is placed into the accumulator data type. These parameters are ignored for other types of inputs.

---

### **Rounding mode**

Select the rounding mode for fixed-point operations.

### **Overflow mode**

Select the overflow mode for fixed-point operations.

### **Product output**

Use this parameter to specify how you would like to designate the product output word and fraction lengths resulting from a complex-complex multiplication in the block. Refer to "Multiplication Data Types" in the Signal Processing Blockset documentation for more information:

- When you select `Same as input`, these characteristics will match those of the input to the block.
- When you select `Binary point scaling`, you can enter the word length and the fraction length of the product output, in bits.
- When you select `Slope and bias scaling`, you can enter the word length, in bits, and the slope of the product output. This block requires power-of-two slope and a bias of zero.

### **Accumulator**

Use this parameter to specify the accumulator word and fraction lengths resulting from a complex-complex multiplication in the block. Refer to "Multiplication Data Types" in the Signal Processing Blockset documentation for more information:



- When you select Same as product output, these characteristics will match those of the product output.
- When you select Same as input, these characteristics will match those of the input to the block.
- When you select Binary point scaling, you can enter the word length and the fraction length of the accumulator, in bits.
- When you select Slope and bias scaling, you can enter the word length, in bits, and the slope of the accumulator. This block requires power-of-two slope and a bias of zero.

### **Lock scaling against changes by the autoscaling tool**

Select this parameter to prevent any fixed-point scaling you specify in this block mask from being overridden by the autoscaling tool in the Fixed-Point Settings interface. For more information about the autoscaling tool, refer to the Fixed-Point Settings Interface section of the Signal Processing Blockset User's Guide.

### **See Also**

2-D Autocorrelation	Video and Image Processing Blockset
2-D Correlation	Video and Image Processing Blockset
2-D Histogram	Video and Image Processing Blockset
2-D Maximum	Video and Image Processing Blockset
2-D Mean	Video and Image Processing Blockset
2-D Median	Video and Image Processing Blockset
2-D Standard Deviation	Video and Image Processing Blockset
2-D Variance	Video and Image Processing Blockset
Minimum	Signal Processing Blockset
min	MATLAB

## 2-D Pad

**Purpose** Pad matrix along its rows and/or columns

**Library** Utilities

**Description** The Pad Matrix block expands the dimensions of a matrix by padding its rows and/or columns at the beginning and/or end with values of your choice.

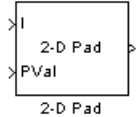

Port	Input/Output	Supported Data Types	Supports Complex Values?
I	Matrix of intensity values or a matrix that represents one plane of the RGB video stream	<ul style="list-style-type: none"><li>• Double-precision floating point</li><li>• Single-precision floating point</li><li>• Fixed point</li></ul>	Yes
PVal	Scalar that represents the constant pad value	Same as I port	Yes
Output	Padded scalar, vector, or matrix	Same as I port	Yes

The data type of the input signal is the data type of the output signal. This block supports a signal represented by a Simulink virtual bus.

Use the **Method** parameter to specify how you pad the input matrix. To pad your matrix with a constant value, select Constant. To pad your input matrix by repeating its border values, select Replicate. To pad your input matrix with its mirror image, select Symmetric. To pad your input matrix using a circular repetition of its elements, select Circular.

If, for the **Method** parameter, you select Constant, the **Pad value source** and **Value** parameters appear on the dialog. If, for the **Pad value source** parameter, you select Input port, the PVal port appears

on the block. Use this port to specify the constant value with which to pad your matrix. If, for the **Pad value source** parameter, you select `Specify via dialog`, the **Value** parameter appears on the dialog box. Enter the constant value with which to pad your matrix.

If, for the **Specify** parameter, you select `Pad size`, you can enter the size of the padding in the horizontal and vertical directions. If you select `Output size`, you can enter the total number of output columns and rows.

The **Pad rows at** parameter controls the padding at the left and/or right side of the input matrix. If you select `Left`, the block adds additional columns to the left side of the matrix. If you select `Right`, the block adds additional columns to the right side of the matrix. If you select `Both left and right`, the block adds additional columns to the left and right side of the matrix. If you select `No padding`, the block does not change the number of columns of the input matrix.

If, for the **Specify** parameter, you select `Pad size`, the **Pad size along rows** parameter appears on the dialog box. Use this parameter to specify the size of the padding in the horizontal direction. Enter a scalar value, and the block adds this number of columns to the left and/or right side of your input matrix. If, for the **Pad rows at** parameter, you selected `Both left and right`, you can also enter a two element vector. The left element controls the number of columns the block adds to the left side of the matrix; the right element controls the number of columns the block adds to the right side of the matrix.

If, for the **Specify** parameter, you select `Output size`, the **Number of output columns** parameter appears on the dialog box. Use this parameter to enter a scalar that represents the total number of output columns.

The **Pad columns at** parameter controls the padding at the top and/or bottom of the input matrix. If you select `Top`, the block adds additional rows at the top of the input matrix. If you select `Bottom`, the block adds additional rows at the bottom of the matrix. If you select `Both top and bottom`, the block adds additional rows at the top and bottom of the

## 2-D Pad

---

matrix. If you select **No padding**, the block does not change the number of rows of the input matrix.

If, for the **Specify** parameter, you select **Pad size**, the **Pad size along columns** parameter appears on the dialog box. Use this parameter to specify the size of the padding in the vertical direction. Enter a scalar value, and the block adds this number of rows to the top and/or bottom of your input matrix. If, for the **Pad columns at** parameter, you selected **Both top and bottom**, you can also enter a two element vector. The left element controls the number of rows the block adds to the top of the matrix; the right element controls the number of rows the block adds to the bottom of the matrix.

If, for the **Specify** parameter, you select **Output size**, the **Number of output rows** parameter appears on the dialog box. Use this parameter to enter a scalar that represents the total number of output rows.

### Examples

#### Example 1

Suppose you want to pad the rows of your input matrix with three initial values equal to 0. Your input matrix is defined as

$$\begin{bmatrix} a_{00} & a_{01} & a_{02} \\ a_{10} & a_{11} & a_{12} \\ a_{20} & a_{21} & a_{22} \end{bmatrix}$$

Set the Pad Matrix block parameters as follows:

- **Method** = Constant
- **Pad value source** = Specify via dialog
- **Value** = 0
- **Specify** = Output size
- **Pad rows at** = Left
- **Number of output columns** = 6

- **Pad columns at** = No padding

The Pad Matrix block outputs the following

$$\begin{bmatrix} 0 & 0 & 0 & a_{00} & a_{01} & a_{02} \\ 0 & 0 & 0 & a_{10} & a_{11} & a_{12} \\ 0 & 0 & 0 & a_{20} & a_{21} & a_{22} \end{bmatrix}$$

matrix:

### Example 2

Suppose you want to pad your input matrix with its border values. Your input matrix is defined as

$$\begin{bmatrix} a_{00} & a_{01} & a_{02} \\ a_{10} & a_{11} & a_{12} \\ a_{20} & a_{21} & a_{22} \end{bmatrix}$$

Set the Pad Matrix block parameters as follows:

- **Method** = Replicate
- **Pad rows at** = Both left and right
- **Pad size along rows** = 2
- **Pad columns at** = Both top and bottom
- **Pad size along columns** = [1 3]

The Pad Matrix block outputs the following matrix:

## 2-D Pad

$$\begin{bmatrix} a_{00} & a_{00} & a_{00} & a_{01} & a_{02} & a_{02} & a_{02} \\ a_{00} & a_{00} & a_{00} & a_{01} & a_{02} & a_{02} & a_{02} \\ a_{10} & a_{10} & a_{10} & a_{11} & a_{12} & a_{12} & a_{12} \\ a_{20} & a_{20} & a_{20} & a_{21} & a_{22} & a_{22} & a_{22} \\ a_{20} & a_{20} & a_{20} & a_{21} & a_{22} & a_{22} & a_{22} \\ a_{20} & a_{20} & a_{20} & a_{21} & a_{22} & a_{22} & a_{22} \\ a_{20} & a_{20} & a_{20} & a_{21} & a_{22} & a_{22} & a_{22} \end{bmatrix} \quad \text{Input matrix}$$

The border values of the input matrix are replicated on the top, bottom, left, and right of the input matrix so that the output is a 7-by-7 matrix. The values in the corners of this output matrix are determined by replicating the border values of the matrices on the top, bottom, left and right side of the original input matrix.

### Example 3

Suppose you want to pad your input matrix using its mirror image. Your input matrix is defined as

$$\begin{bmatrix} a_{00} & a_{01} & a_{02} \\ a_{10} & a_{11} & a_{12} \\ a_{20} & a_{21} & a_{22} \end{bmatrix}$$

Set the Pad Matrix block parameters as follows:

- **Method** = Symmetric
- **Pad rows at** = Both left and right

- Pad size along rows = [5 6]
- Pad columns at = Both top and bottom
- Pad size along columns = 2

The Pad Matrix block outputs the following matrix:

$$\begin{bmatrix}
 a_{11} & a_{12} & a_{12} & a_{11} & a_{10} & a_{10} & a_{11} & a_{12} & a_{12} & a_{11} & a_{10} & a_{10} & a_{11} & a_{12} \\
 a_{01} & a_{02} & a_{02} & a_{01} & a_{00} & a_{00} & a_{01} & a_{02} & a_{02} & a_{01} & a_{00} & a_{00} & a_{01} & a_{02} \\
 a_{01} & a_{02} & a_{02} & a_{01} & a_{00} & a_{00} & a_{01} & a_{02} & a_{02} & a_{01} & a_{00} & a_{00} & a_{01} & a_{02} \\
 a_{11} & a_{12} & a_{12} & a_{11} & a_{01} & a_{10} & a_{11} & a_{12} & a_{12} & a_{11} & a_{10} & a_{10} & a_{11} & a_{12} \\
 a_{21} & a_{22} & a_{22} & a_{21} & a_{20} & a_{20} & a_{21} & a_{22} & a_{22} & a_{21} & a_{20} & a_{20} & a_{21} & a_{22} \\
 a_{21} & a_{22} & a_{22} & a_{21} & a_{20} & a_{20} & a_{21} & a_{22} & a_{22} & a_{21} & a_{20} & a_{20} & a_{21} & a_{22} \\
 a_{11} & a_{12} & a_{12} & a_{11} & a_{01} & a_{01} & a_{11} & a_{12} & a_{12} & a_{11} & a_{10} & a_{10} & a_{11} & a_{12}
 \end{bmatrix} \text{Input matrix}$$

The block flips the original input matrix and each matrix it creates about their top, bottom, left, and right sides to populate the 7-by-13 output matrix.

### Example 4

Suppose you want to pad your input matrix using a circular repetition of its values. Your input matrix is defined as

$$\begin{bmatrix}
 a_{00} & a_{01} & a_{02} \\
 a_{10} & a_{11} & a_{12} \\
 a_{20} & a_{21} & a_{22}
 \end{bmatrix}$$

Set the Pad Matrix block parameters as follows:

## 2-D Pad

---

- **Method** = Circular
- **Pad rows at** = Both left and right
- **Pad size along rows** = 3
- **Pad columns at** = Both top and bottom
- **Pad size along columns** = 3

The Pad Matrix block outputs the following

$$\begin{bmatrix} a_{00} & a_{01} & a_{02} & a_{00} & a_{01} & a_{02} & a_{00} & a_{01} & a_{02} \\ a_{10} & a_{11} & a_{12} & a_{10} & a_{11} & a_{12} & a_{10} & a_{11} & a_{12} \\ a_{20} & a_{21} & a_{22} & a_{20} & a_{21} & a_{22} & a_{20} & a_{21} & a_{22} \\ \hline a_{00} & a_{01} & a_{02} & a_{00} & a_{01} & a_{02} & a_{00} & a_{01} & a_{02} \\ a_{10} & a_{11} & a_{12} & a_{10} & a_{11} & a_{12} & a_{10} & a_{11} & a_{12} \\ a_{20} & a_{21} & a_{22} & a_{20} & a_{21} & a_{22} & a_{20} & a_{21} & a_{22} \\ \hline a_{00} & a_{01} & a_{02} & a_{00} & a_{01} & a_{02} & a_{00} & a_{01} & a_{02} \\ a_{10} & a_{11} & a_{12} & a_{10} & a_{11} & a_{12} & a_{10} & a_{11} & a_{12} \\ a_{20} & a_{21} & a_{22} & a_{20} & a_{21} & a_{22} & a_{20} & a_{21} & a_{22} \end{bmatrix}$$

Input matrix

matrix:

The block repeats the values of the input matrix in a circular pattern to populate the 9-by-9 output matrix.

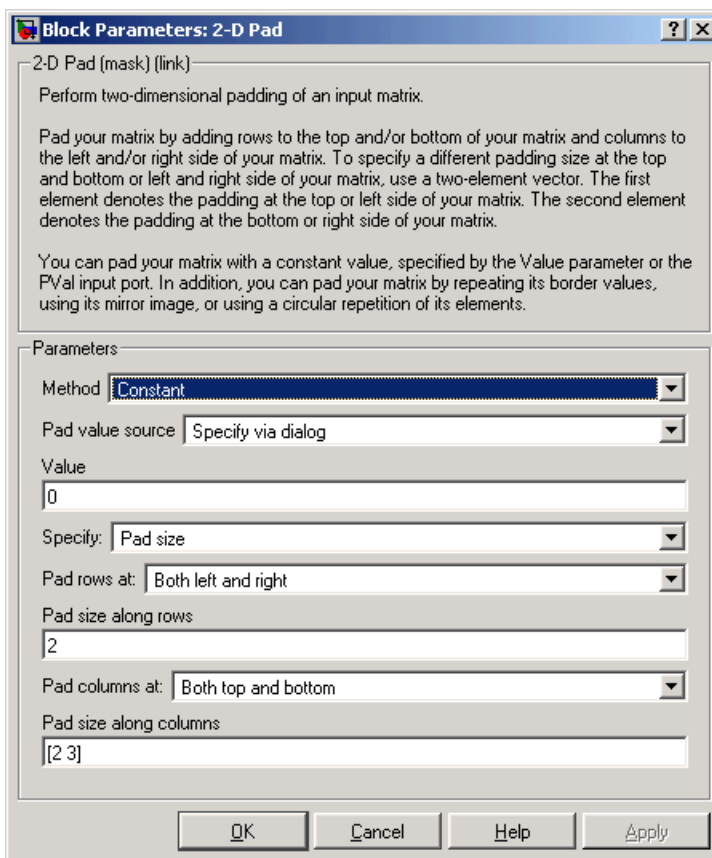

**Dialog  
Box****Method**

Specify how you want the block to pad your matrix. To pad your matrix with a constant value, select **Constant**. To pad your input matrix with its border values, select **Replicate**. To pad your input matrix with its mirror image, select **Symmetric**. To pad your input matrix using a circular repetition of its elements, select **Circular**.

## 2-D Pad

---

### **Pad value source**

If you select `Input port`, the `PVal` port appears on the block. Use this port to specify the constant value with which to pad your matrix. If you select `Specify via dialog`, the **Value** parameter becomes available. This parameter is visible if, for the **Method** parameter, you select `Constant`.

### **Value**

Enter the constant value with which to pad your matrix. This parameter is visible if, for the **Method** parameter, you select `Constant`. This parameter is available if, for the **Pad value source** parameters, you select `Specify via dialog`. Tunable.

### **Specify**

If you select `Pad size`, you can enter the size of the padding in the horizontal and vertical directions. If you select `Output size`, you can enter the total number of output columns and rows.

### **Pad rows at**

Select `Left` to add additional columns to the left side of the matrix. Select `Right` to add additional columns to the right side of the matrix. Select `Both left and right` to add additional columns to the left and right side of the matrix. If you select `No padding`, the block does not change the number of columns of the input matrix.

### **Pad size along rows**

This parameter controls how many columns are added to the right and/or left side of your input matrix. Enter a scalar value, and the block adds this number of columns to the left and/or right side of your matrix. If, for the **Pad rows at** parameter you selected `Both left and right`, enter a two-element vector. The left element controls the number of columns the block adds to the left side of the matrix and the right element controls how many columns the block adds to the right side of the matrix. This parameter is visible if, for the **Specify** parameter, you select `Pad size`.

### **Number of output columns**

Enter a scalar that represents the total number of output columns. This parameter is visible if, for the **Specify** parameter, you select Output size.

### **Pad columns at**

Select Top to add additional rows at the top of the input matrix. Select Bottom to add additional rows at the bottom of the matrix. Select Both top and bottom to add additional rows at the top and bottom of the matrix. If you select No padding, the block does not change the number of rows of the input matrix.

### **Pad size along columns**

This parameter controls how many rows are added to the top and/or bottom of your input matrix. Enter a scalar value and the block adds this number of columns to the top and/or bottom of your matrix. If, for the **Pad columns at** parameter you selected Both top and bottom, enter a two-element vector. The left element controls the number of rows the block adds to the top of the matrix and the right element controls how many rows the block adds to the bottom of the matrix. This parameter is visible if, for the **Specify** parameter, you select Pad size.

### **Number of output rows**

Enter a scalar that represents the total number of output rows. This parameter is visible if, for the **Specify** parameter, you select Output size.

# 2-D Standard Deviation

**Purpose** Find standard deviation of each input matrix

**Library** Statistics

## Description

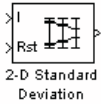
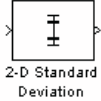

The 2-D Standard Deviation block computes the standard deviation of each M-by-N input matrix or of a sequence of inputs over a period of time. Use the **Running standard deviation** check box to select between the block's basic and running operation. This block's functionality is different from the Signal Processing Blockset Standard Deviation block, which computes the standard deviation of each column in the input.

Port	Input/Output	Supported Data Types	Supports Complex Values?
Input / I	Scalar, vector, or matrix of intensity values or scalar, vector, or matrix that represents one plane of the input RGB video stream	<ul style="list-style-type: none"><li>• Double-precision floating point</li><li>• Single-precision floating point</li></ul>	Yes

Port	Input/Output	Supported Data Types	Supports Complex Values?
Rst	Signal that triggers a reset event	<ul style="list-style-type: none"> <li>• Double-precision floating point</li> <li>• Single-precision floating point</li> <li>• Boolean</li> <li>• 8-, 16-, and 32-bit signed integers</li> <li>• 8-, 16-, and 32-bit unsigned integers</li> </ul>	No
Output	Standard deviation of each M-by-N input matrix, or the standard deviation of a sequence of M-by-N inputs	Same as Input port	Yes

Length-M 1-D vector inputs are treated as M-by-1 column vectors.

### Basic Operation

If you clear the **Running standard deviation** check box, the block outputs the standard deviation of each M-by-N input matrix.

For purely real or purely imaginary inputs, the standard deviation is the square root of the variance and is given by the following equation:

$$y = \sigma = \sqrt{\frac{\sum_{i=1}^M \sum_{j=1}^N (u_{ij} - \mu)^2}{M \times N - 1}}$$

where  $\mu$  is the mean of the input matrix  $u$ . For complex inputs, the block outputs the total standard deviation of the input matrix, which is the square root of the total variance.

## 2-D Standard Deviation

---

$$\sigma = \sqrt{\sigma_{\text{Re}}^2 + \sigma_{\text{Im}}^2}$$

Note that the total standard deviation is not equal to the sum of the real and imaginary standard deviations.

### Running Operation

If you select the **Running standard deviation** check box, the block computes the standard deviation of a sequence of M-by-N inputs.

For example, suppose A is the first input to the block and B is the second and current input to the block, where

$$A = \begin{bmatrix} 1 & 3 \\ 2 & 4 \end{bmatrix}$$

and

$$B = \begin{bmatrix} 5 & 6 \\ 7 & 3 \end{bmatrix}$$

The block computes the standard deviation as

$$\begin{bmatrix} \text{std}([1,5]) & \text{std}([3,6]) \\ \text{std}([2,7]) & \text{std}([4,3]) \end{bmatrix}$$

and outputs

$$\begin{bmatrix} 2.8284 & 2.1213 \\ 3.5355 & 0.7071 \end{bmatrix}$$

For the next input, the block computes the standard deviation for each element of the first three inputs, and so on.

### Resetting the Running Standard Deviation

The block resets the running standard deviation whenever a reset event is detected at the optional Rst port. The reset signal rate must be a positive integer multiple of the rate of the data signal input.

You specify the reset event in the **Reset port** parameter:

- None disables the Rst port.
- Rising edge – Triggers a reset operation when the Rst input does one of the following:
  - Rises from a negative value to a positive value or zero
  - Rises from zero to a positive value, where the rise is not a continuation of a rise from a negative value to zero (see the following figure)

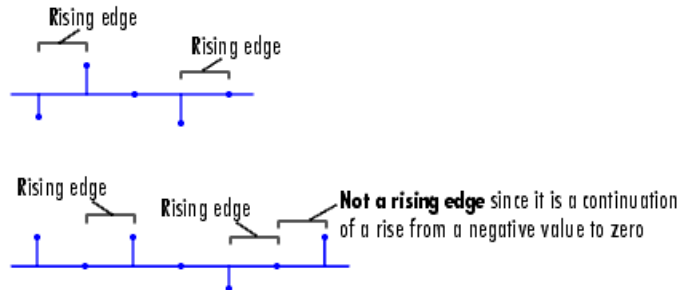

- Falling edge – Triggers a reset operation when the Rst input does one of the following:
  - Falls from a positive value to a negative value or zero
  - Falls from zero to a negative value, where the fall is not a continuation of a fall from a positive value to zero (see the following figure)

## 2-D Standard Deviation

---

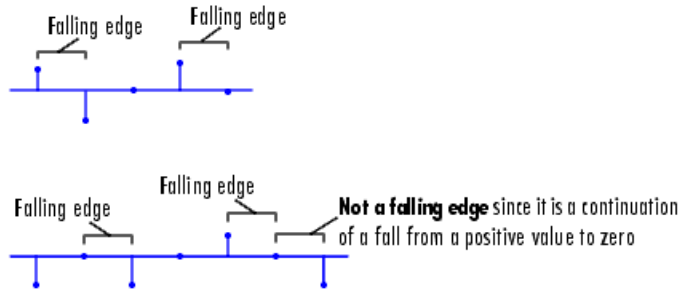

- Either edge – Triggers a reset operation when the Rst input is a Rising edge or Falling edge (as described above).
- Non-zero sample – Triggers a reset operation at each sample time that the Rst input is not zero.

---

**Note** When running simulations in the Simulink MultiTasking mode, reset signals have a one-sample latency. Therefore, when the block detects a reset event, there is a one-sample delay at the reset port rate before the block applies the reset. For more information on latency and the Simulink tasking modes, see "The Configuration Parameters Dialog Box" in the Simulink documentation.

---



## Dialog Box

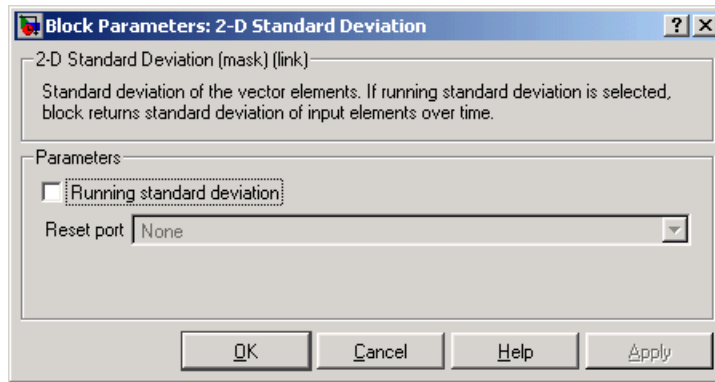

### Running standard deviation

Select this check box to enable the block's running operation.

### Reset port

Determines the reset event that causes the block to reset the running standard deviation. The reset signal rate must be a positive integer multiple of the rate of the data signal input. This parameter is available if you select the **Running standard deviation** check box.

## See Also

2-D Autocorrelation	Video and Image Processing Blockset
2-D Correlation	Video and Image Processing Blockset
2-D Histogram	Video and Image Processing Blockset
2-D Maximum	Video and Image Processing Blockset
2-D Mean	Video and Image Processing Blockset
2-D Median	Video and Image Processing Blockset
2-D Minimum	Video and Image Processing Blockset
2-D Variance	Video and Image Processing Blockset

## 2-D Standard Deviation

---

Standard Deviation

std

Signal Processing Blockset

MATLAB

**Purpose** Compute variance of each input matrix

**Library** Statistics

**Description** The 2-D Variance block computes the variance of each M-by-N input matrix or of a sequence of inputs over a period of time. Use the **Running variance** check box to choose between the block's basic and running operation. This block's functionality is different from the Signal Processing Blockset Variance block, which computes the variance of each column in the input.

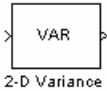

Port	Input/Output	Supported Data Types	Supports Complex Values?
Input / I	Scalar, vector, or matrix of intensity values or scalar, vector, or matrix that represents one plane of the input RGB video stream	<ul style="list-style-type: none"> <li>• Double-precision floating point</li> <li>• Single-precision floating point</li> <li>• Fixed point</li> <li>• 8-, 16-, and 32-bit signed integers</li> <li>• 8-, 16-, and 32-bit unsigned integers</li> </ul>	Yes

## 2-D Variance

Port	Input/Output	Supported Data Types	Supports Complex Values?
Rst	Signal that triggers a reset event	<ul style="list-style-type: none"> <li>• Double-precision floating point</li> <li>• Single-precision floating point</li> <li>• Boolean</li> <li>• 8-, 16-, and 32-bit signed integers</li> <li>• 8-, 16-, and 32-bit unsigned integers</li> </ul>	No
Output	Variance of each M-by-N input matrix, or the variance of a sequence of M-by-N inputs	Same as Input port	Yes

Length-M 1-D vector inputs are treated as M-by-1 column vectors.

### Basic Operation

If you clear the **Running variance** check box, the block outputs the variance of each M-by-N input matrix. Note that a scalar input generates a zero-valued output.

For purely real or purely imaginary inputs, the variance of a M-by-N matrix is the square of the standard deviation:

$$y = \sigma^2 = \frac{\sum_{i=1}^M \sum_{j=1}^N |u_{ij}|^2 - \frac{\left| \sum_{i=1}^M \sum_{j=1}^N u_{ij} \right|^2}{M * N - 1}}{M * N - 1}$$

For complex inputs, the variance is given by the following equation:

$$\sigma^2 = \sigma_{\text{Re}}^2 + \sigma_{\text{Im}}^2$$

When the input values are double-precision floating point, the equivalent MATLAB code is `var(u(:))`, where `u` is the input.

### Running Operation

If you select the **Running variance** check box, the block computes the variance of a sequence of M-by-N inputs.

For example, suppose `A` is the first input to the block and `B` is the second and current input to the block, where

$$A = \begin{bmatrix} 1 & 3 \\ 2 & 4 \end{bmatrix}$$

and

$$B = \begin{bmatrix} 5 & 6 \\ 7 & 3 \end{bmatrix}$$

The block computes the variance,

$$\begin{bmatrix} \text{var}([1,5]) & \text{var}([3,6]) \\ \text{var}([2,7]) & \text{var}([4,3]) \end{bmatrix}$$

and outputs

$$\begin{bmatrix} 8 & 4.5 \\ 12.5 & 0.5 \end{bmatrix}$$

For the next input, the block computes the variance for each element of the first three inputs, and so on.

## 2-D Variance

---

### Resetting the Running Variance

The block resets the running variance whenever a reset event is detected at the optional Rst port. The reset signal rate must be a positive integer multiple of the rate of the data signal input.

You specify the reset event in the **Reset port** parameter:

- None disables the Rst port.
- Rising edge – Triggers a reset operation when the Rst input does one of the following:
  - Rises from a negative value to a positive value or zero
  - Rises from zero to a positive value, where the rise is not a continuation of a rise from a negative value to zero (see the following figure)

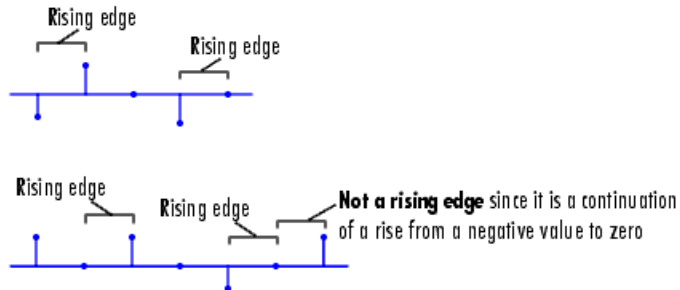

- Falling edge – Triggers a reset operation when the Rst input does one of the following:
  - Falls from a positive value to a negative value or zero
  - Falls from zero to a negative value, where the fall is not a continuation of a fall from a positive value to zero (see the following figure)

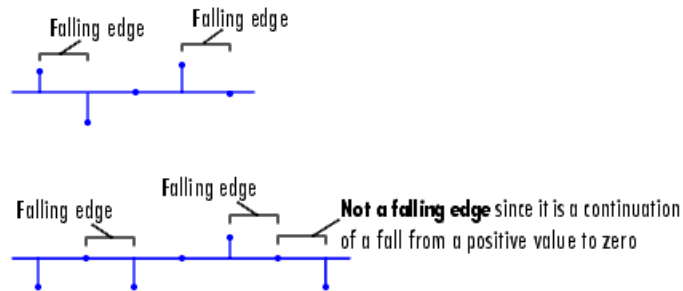

- Either edge – Triggers a reset operation when the Rst input is a Rising edge or Falling edge (as described above)
- Non-zero sample – Triggers a reset operation at each sample time that the Rst input is not zero

---

**Note** When running simulations in the Simulink MultiTasking mode, reset signals have a one-sample latency. Therefore, when the block detects a reset event, there is a one-sample delay at the reset port rate before the block applies the reset. For more information on latency and the Simulink tasking modes, see "The Configuration Parameters Dialog Box" in the Simulink documentation.

---

### Fixed-Point Data Types

The following diagram shows the data types used within the 2-D Variance block for fixed-point signals.

## 2-D Variance

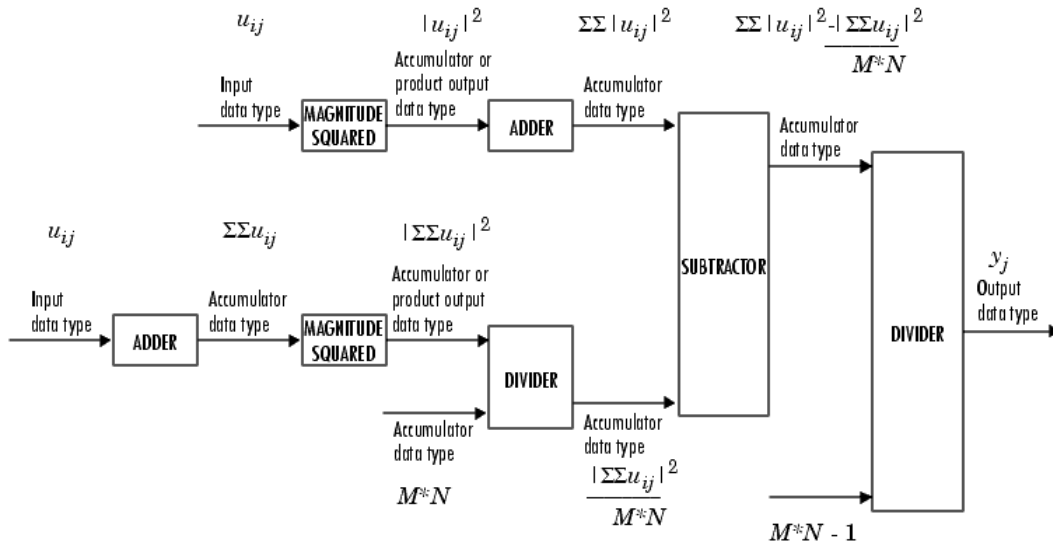

The results of the magnitude squared calculations above are in the product output data type. You can set the accumulator, product output, and output data types in the block dialog box.



## Dialog Box

The **Main** pane of the 2-D Variance block dialog appears as follows:

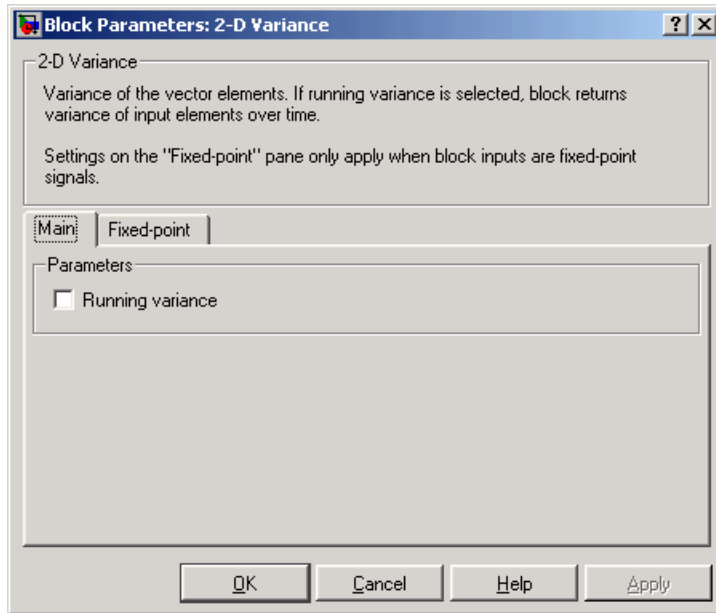

### Running variance

Select this check box to enable the block's running operation.

### Reset port

Determines the reset event that causes the block to reset the running variance. The reset signal rate must be a positive integer multiple of the rate of the data signal input. This parameter is visible if you select the **Running variance** check box.

The **Fixed-point** pane of the 2-D Variance block dialog appears as follows:

## 2-D Variance

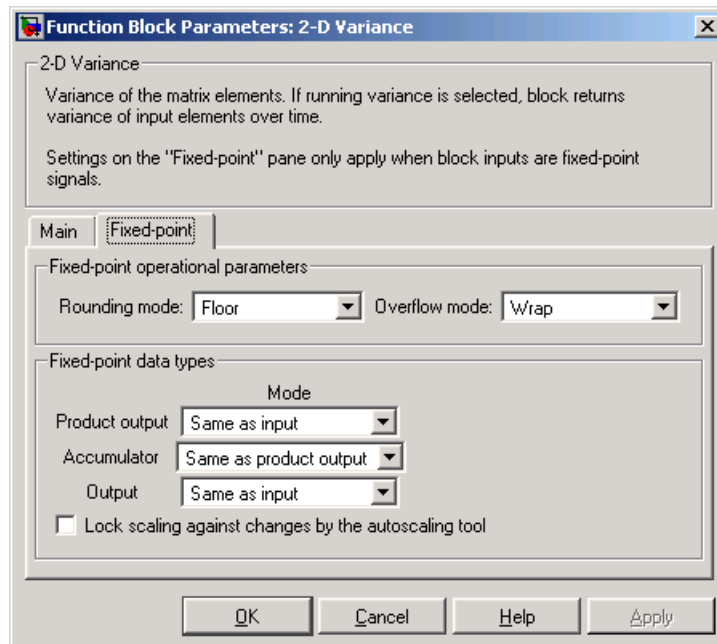

### **Rounding mode**

Select the rounding mode for fixed-point operations.

### **Overflow mode**

Select the overflow mode for fixed-point operations.

---

**Note** Refer to “Fixed-Point Data Types” on page 9-149 for more information on how the product output, accumulator, and output data types are used in this block.

---

### **Product output**

Use this parameter to specify how you would like to designate the product output word and fraction lengths:

- When you select `Same as input`, these characteristics will match those of the input to the block.
- When you select `Binary point scaling`, you can enter the word length and the fraction length of the product output, in bits.
- When you select `Slope and bias scaling`, you can enter the word length, in bits, and the slope of the product output. This block requires power-of-two slope and a bias of zero.

### **Accumulator**

Use this parameter to specify the accumulator word and fraction lengths resulting from a complex-complex multiplication in the block:

- When you select `Same as product output`, these characteristics will match those of the product output
- When you select `Same as input`, these characteristics will match those of the input to the block.
- When you select `Binary point scaling`, you can enter the word length and the fraction length of the accumulator, in bits.
- When you select `Slope and bias scaling`, you can enter the word length, in bits, and the slope of the accumulator. This block requires power-of-two slope and a bias of zero.

### **Output**

Choose how you will specify the output word length and fraction length:

- When you select `Same as input`, these characteristics will match those of the input to the block.
- When you select `Binary point scaling`, you can enter the word length and the fraction length of the output, in bits.
- When you select `Slope and bias scaling`, you can enter the word length, in bits, and the slope of the output. This block requires power-of-two slope and a bias of zero.

## 2-D Variance

---

### Lock scaling against changes by the autoscaling tool

Select this parameter to prevent any fixed-point scaling you specify in this block mask from being overridden by the autoscaling tool in the Fixed-Point Settings interface. For more information about the autoscaling tool, refer to the Fixed-Point Settings Interface section of the Signal Processing Blockset User's Guide.

### See Also

2-D Autocorrelation	Video and Image Processing Blockset
2-D Correlation	Video and Image Processing Blockset
2-D Histogram	Video and Image Processing Blockset
2-D Maximum	Video and Image Processing Blockset
2-D Mean	Video and Image Processing Blockset
2-D Median	Video and Image Processing Blockset
2-D Minimum	Video and Image Processing Blockset
2-D Standard Deviation	Video and Image Processing Blockset
Variance	Signal Processing Blockset
var	MATLAB

**Purpose** Convert intensity image to binary image

**Library** Conversions

**Description** Use the Autothreshold block to convert an intensity image to a binary image using a threshold value computed using Otsu's method. The block computes this threshold value by splitting the histogram of the input image such that the variance of each pixel group is minimized.

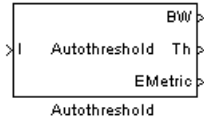

Port	Input/Output	Supported Data Types	Supports Complex Values?
I	Scalar, vector, or matrix of intensity values or scalar, vector, or matrix that represents one plane of the RGB video stream	<ul style="list-style-type: none"> <li>• Double-precision floating point</li> <li>• Single-precision floating point</li> </ul>	No
BW	Scalar, vector, or matrix that represents a binary image	<ul style="list-style-type: none"> <li>• Boolean</li> </ul>	No
Th	Threshold value	Same as I port	No
EMetric	Effectiveness metric	Same as I port	No

Use the **Thresholding operator** parameter to specify the condition the block places on the input values. If you select > and the input value is greater than the threshold value, the block outputs 1 at the BW port; otherwise, it outputs 0. If you select <= and the input value is less than or equal to the threshold value, the block outputs 1; otherwise, it outputs 0.

Select the **Output threshold** check box to output the calculated threshold values at the Th port.

Select the **Output effectiveness metric** check box to output values that represent the effectiveness of the thresholding at the EMetric port. This metric ranges between 0 and 1. If all the pixels of the image

# Autothreshold

---

have the same value, the effectiveness metric is 0. If the image has two pixel values or the histogram of the image pixels is symmetric, the effectiveness metric is 1.

If you clear the **Specify data range** check box the block assumes that floating-point input values range from 0 to 1. If you want to specify a different data range, select this check box. The **Minimum value of input** and **Maximum value of input** parameters appear on the dialog box. Use these parameters to enter the minimum and maximum values of your input signal.

Use the **When data range is exceeded** parameter to specify the block's behavior when the input values are outside the expected range. The following options are available:

- Ignore – Proceed with the computation and do not issue a warning message. If you choose this option, the block performs the most efficient computation. However, if the input values exceed the expected range, the block produces incorrect results.
- Saturate – Change any input values outside the range to the minimum or maximum value of the range and proceed with the computation.
- Warn and saturate – Display a warning message in the MATLAB Command Window, saturate values, and proceed with the computation.
- Error — Display an error dialog box and terminate the simulation.

## Dialog Box

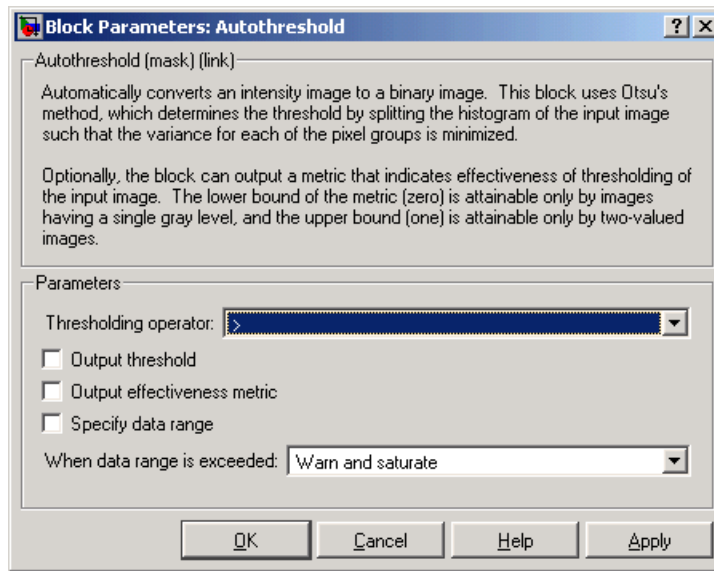

### Thresholding operator

Specify the condition the block places on the input matrix values.

If you select > or <=, the block outputs 0 or 1 depending on whether the input matrix values are above, below, or equal to the threshold value.

### Output threshold

Select this check box to output the calculated threshold values at the Th port.

### Output effectiveness metric

Select this check box to output values that represent of the effectiveness of the thresholding at the EMetric port.

### Specify data range

If you clear this check box the block assumes that floating-point input values range from 0 to 1. If you want to specify a different data range, select this check box.

# Autothreshold

---

## **Minimum value of input**

Enter the minimum value of your input data. This parameter is visible if you select the **Specify data range** check box. Tunable.

## **Maximum value of input**

Enter the maximum value of your input data. This parameter is visible if you select the **Specify data range** check box. Tunable.

## **When data range is exceeded**

Specify the block's behavior when the input values are outside the expected range. Your options are Ignore, Saturate, Warn and saturate, or Error.

## **See Also**

Compare to Constant	Simulink
Relational Operator	Simulink



**Purpose** Compute statistical values for labeled regions

**Library** Statistics

**Description** Use the Blob Analysis block to calculate statistics for labeled regions in a binary image. The block returns some quantities, such as the Centroid, as values that represent spatial coordinate locations. For information about how pixel and spatial coordinate systems are defined in the Video and Image Processing Blockset, see “Coordinate Systems” on page 1-13.

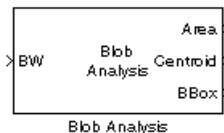

Use the Variable Selector block to select certain blobs based on their statistics. For more information about this block, see the Variable Selector block reference page in the Signal Processing Blockset documentation.

Port	Input/Output	Supported Data Types	Supports Complex Values?
BW	Vector or matrix that represents a binary image	<ul style="list-style-type: none"> <li>• Boolean</li> </ul>	No
Area	Vector whose elements represent the number of pixels in labeled regions	<ul style="list-style-type: none"> <li>• 32-bit signed integers</li> </ul>	No
Centroid	2-by-N matrix of centroid coordinates, where N is the number of blobs	<ul style="list-style-type: none"> <li>• Double-precision floating point</li> <li>• Single-precision floating point</li> <li>• Fixed point</li> </ul>	No
BBox	4-by-N matrix of bounding box coordinates, where N is the number of blobs	<ul style="list-style-type: none"> <li>• 32-bit signed integers</li> </ul>	No

# Blob Analysis

Port	Input/Output	Supported Data Types	Supports Complex Values?
MajorAxis	Vector whose elements represent the lengths of major axes of ellipses	<ul style="list-style-type: none"><li>• Double-precision floating point</li><li>• Single-precision floating point</li></ul>	No
MinorAxis	Vector whose elements represent the lengths of minor axes of ellipses	Same as MajorAxis port	No
Orientation	Vector whose values represent the angles between the major axes of the ellipses and the <i>c</i> -axis	Same as MajorAxis port	No
Eccentricity	Vector whose values represent the eccentricities of the ellipses	Same as MajorAxis port	No
Diameter^2	Vector whose values represent the equivalent diameters squared	Same as Centroid port	No
Extent	Vector whose values represent the results of dividing the areas of the blobs by the area of their bounding boxes	Same as Centroid port	No

Port	Input/Output	Supported Data Types	Supports Complex Values?
Label	Label matrix	<ul style="list-style-type: none"> <li>8-, 16-, or 32-bit unsigned integers</li> </ul>	No
Count	Scalar that represents the actual number of labeled regions in each image	Same as Label port	No

Use the check boxes to specify the statistics values you want the block to output. The following table summarizes the block's behavior based on which check box you select. For a full description of each of these statistics, see the `regionprops` function reference page in the Image Processing Toolbox documentation.

Check Box	Block Output
Area	Vector whose elements represent the number of pixels in labeled regions
Centroid	<p>2-by-N matrix whose columns represent the coordinates of the centroid of each region, where N is the number of blobs. For example, if there are two blobs and the row and column coordinates of their centroids are <math>r1</math>, <math>c1</math> and <math>r2</math>, <math>c2</math>, respectively, the block outputs</p> $\begin{bmatrix} r1 & r2 \\ c1 & c2 \end{bmatrix}$ <p>at the Centroid port.</p>

# Blob Analysis

Check Box	Block Output
Bounding box	<p>4-by-N matrix whose columns represent the coordinates of each bounding box, where N is the number of blobs. For example, suppose there are two blobs, where <math>r</math> and <math>c</math> define the row and column location of the upper left corner of the bounding box and <math>w</math> and <math>h</math> define the width and height of the bounding box, the block outputs</p> $\begin{bmatrix} r1 & r2 \\ c1 & c2 \\ h1 & h2 \\ w1 & w2 \end{bmatrix}$ <p>at the BBox port.</p>
Major axis length	Vector whose values represent the lengths of the major axes of ellipses that have the same normalized second central moments as the labeled regions
Minor axis length	Vector whose values represent the lengths of the minor axes of ellipses that have the same normalized second central moments as the labeled regions
Orientation	Vector whose values represent the angles between the major axes of ellipses and the $x$ -axis
Eccentricity	Vector whose values represent the eccentricities of ellipses that have the same second moments as the origin
Equivalent diameter squared	Vector whose values represent the equivalent diameters squared
Extent	Vector whose values represent the results of dividing the areas of the blobs by the area of their bounding boxes

Use the **Maximum number of blobs** parameter to specify the maximum number of labeled regions in each input image. The block uses this value to preallocate vectors and matrices so that they are long enough to hold all of the statistical values. If you select the **Output**

**number of blobs found** check box, the block outputs a scalar that represents the actual number of connected regions in each image at the Count port.

Use the **Output data type** parameter to specify the data type of the outputs at the Centroid, MajorAxis, MinorAxis, Orientation, Eccentricity, Diameter<sup>2</sup>, and Extent ports. If you select **Fixed-point**, the block cannot calculate the major axis, minor axis, orientation, or eccentricity and these check boxes become unavailable

If the number of blobs found in an image is less than the scalar entered for the **Maximum number of blobs** parameter, the block has empty spaces in the statistics output arrays. If you select the **Fill empty spaces in outputs** check box, the block fills the empty spaces with the scalar you specify in the **Fill values** parameter. If you enter a vector for the **Fill values** parameter, it must have the same length as the number of selected statistics. The block uses each vector element to fill a different statistics vector. If the empty spaces do not affect your computation, you can deselect the **Fill empty spaces in outputs** check box. Otherwise, we recommend leaving it selected.

Use the **Connectivity** parameter to define which pixels are connected to each other. If you want a pixel to be connected to the other pixels located on the top, bottom, left, and right, select 4. If you want a pixel to be connected to the other pixels on the top, bottom, left, right, and diagonally, select 8. For more information about this parameter, see the Label block reference page.

If you select the **Output label matrix** check box, the block outputs the label matrix, where pixels equal to 0 represent the background, pixels equal to 1 represent the first object, pixels equal to 2 represent the second object, and so on, at the Label port.

## Fixed-Point Data Types

The following diagram shows the data types used within the Blob Analysis block for fixed-point signals.

# Blob Analysis

---

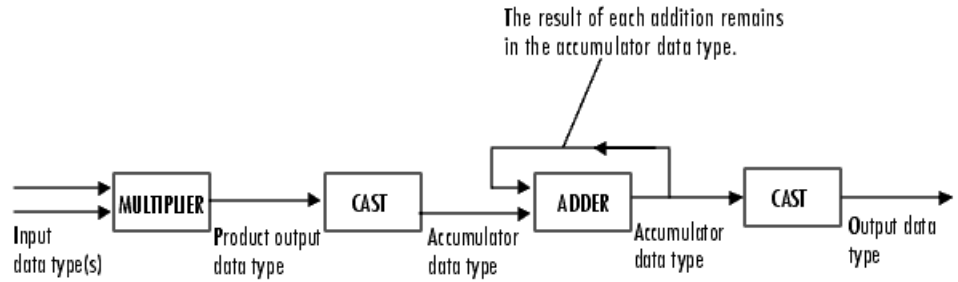

You can set the product output, accumulator, centroid output, equivalent diameter squared output, and extent output data types in the block mask as discussed below.

## Dialog Box

The **Main** pane of the Blob Analysis block dialog box appears as follows:

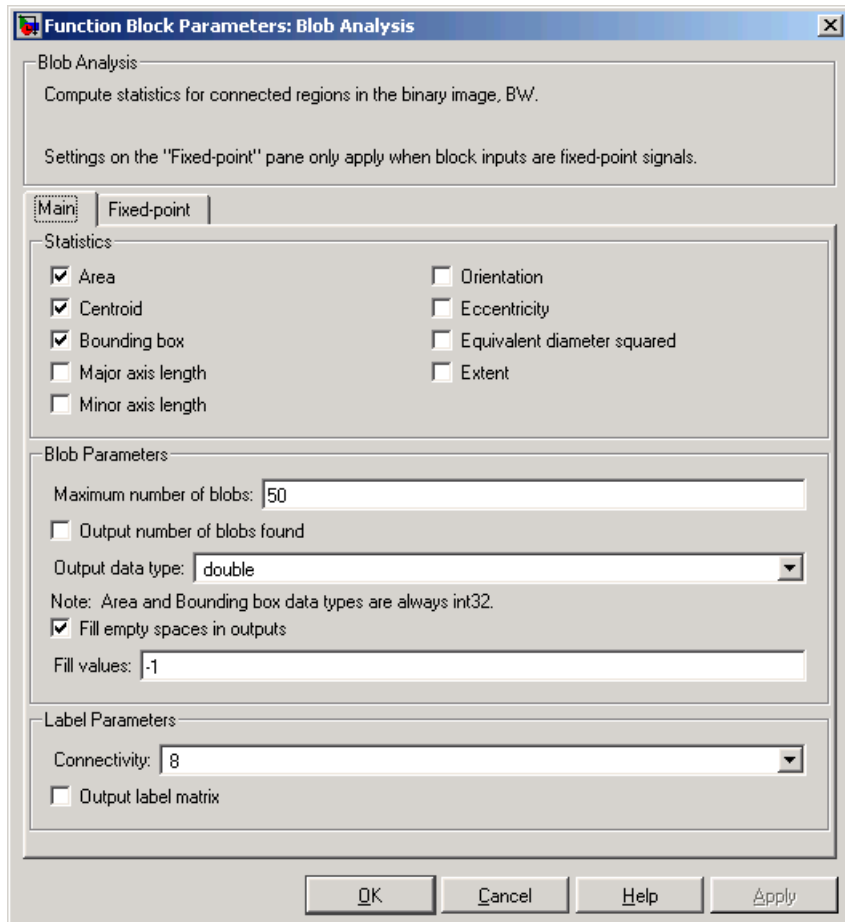

### Area

Select this check box to output the area of the blobs.

# Blob Analysis

---

## **Centroid**

Select this check box to output the 2-by-N matrix whose columns represent the coordinates of the centroid of each labeled region.

## **Bounding box**

Select this check box to output the coordinates of the bounding boxes.

## **Major axis length**

Select this check box to output a vector whose values represent the lengths of the major axes of the ellipses that have the same normalized second central moments as the labeled regions.

## **Minor axis length**

Select this check box to output a vector whose values represent the lengths of the minor axes of the ellipses that have the same normalized second central moments as the labeled regions.

## **Orientation**

Select this check box to output a vector whose values represent the angles between the major axes of the ellipses and the *c*-axis.

## **Eccentricity**

Select this check box to output a vector whose values represent the eccentricities of the ellipses that have the same second moments as the origin.

## **Equivalent diameter squared**

Select this check box to output a vector whose values represent the equivalent diameters squared.

## **Extent**

Select this check box to output a vector whose values represent the results of dividing the areas of the blobs by the area of their bounding boxes.

## **Maximum number of blobs**

Specify the maximum number of labeled regions in each input image.



## **Output number of blobs found**

If you select this check box, the block outputs a scalar that represents the actual number of labeled regions in each image at the Count port.

## **Output data type**

Specify the data type of the outputs at the Centroid, MajorAxis, MinorAxis, Orientation, Eccentricity, Diameter<sup>2</sup>, and Extent ports.

## **Fill empty spaces in outputs**

If you select this check box, the block fills the empty spaces in the statistical vectors with the value(s) you specify in the **Fill values** parameter.

## **Fill values**

If you enter a scalar, the block fills all the empty spaces in the statistical vectors with this value. If you enter a vector, it must have the same length as the number of selected statistics. The block uses each vector element to fill a different statistics vector.

## **Connectivity**

Specify which pixels are connected to each other. If you want a pixel to be connected to the pixels on the top, bottom, left, and right, select 4. If you want a pixel to be connected to the pixels on the top, bottom, left, right, and diagonally, select 8.

## **Output label matrix**

If you select this check box, the block outputs the label matrix at the Label port.

The **Fixed-point** pane of the Blob Analysis block dialog box appears as follows. These parameters are applicable only when the **Output data type** parameter is set to Specify via Fixed-point tab.

# Blob Analysis

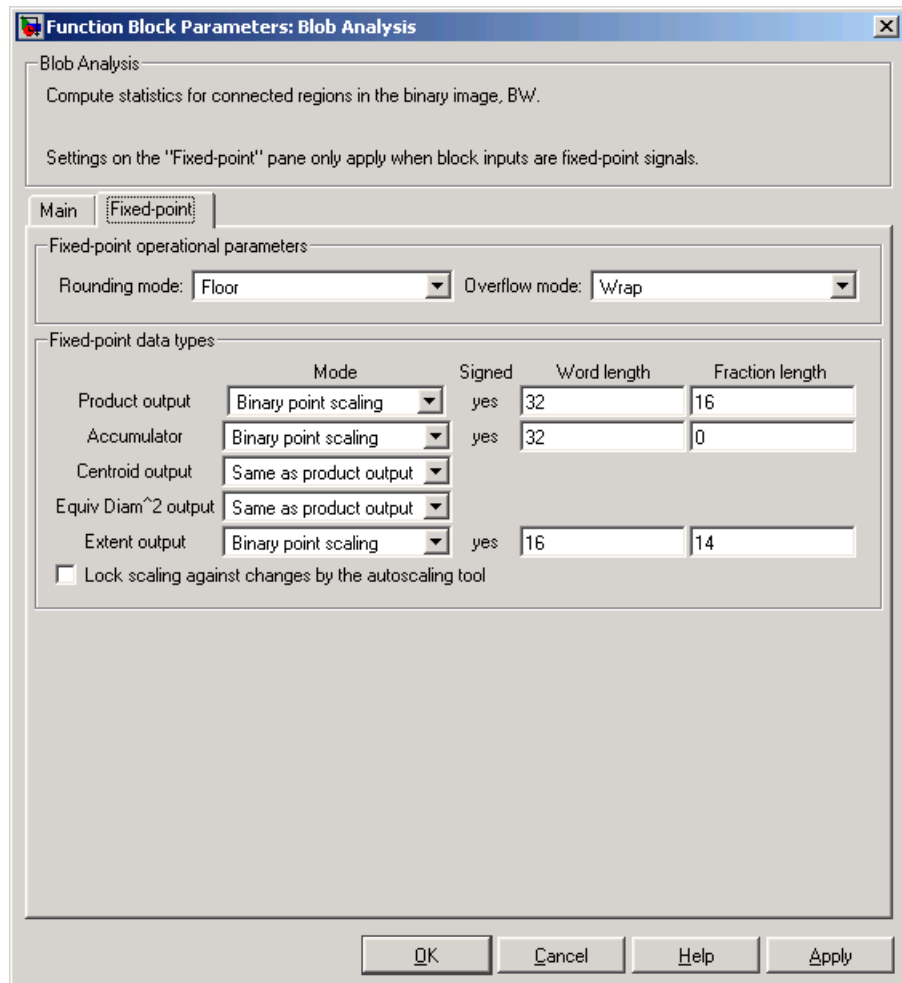

## **Rounding mode**

Select the rounding mode for fixed-point operations.

## **Overflow mode**

Select the overflow mode for fixed-point operations.

## Product output



As depicted above, the output of the multiplier is placed into the product output data type and scaling. The product output data type is used during the computation of the equivalent diameter squared. During this computation, the blob area, which is stored in the accumulator, is multiplied by the  $4/\pi$  factor. This factor has a word length that is equal to the equivalent diameter squared output data type's word length and a fraction length that is equal to its word length minus two. Use this parameter to specify how you would like to designate this product output word and fraction lengths.

- When you select Binary point scaling, you can enter the word length and the fraction length of the product output, in bits.
- When you select Slope and bias scaling, you can enter the word length, in bits, and the slope of the product output. The bias of all signals in the Video and Image Processing Blockset is zero.

## Accumulator

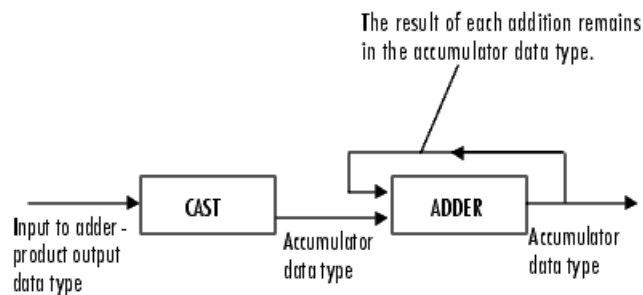

As depicted above, inputs to the accumulator are cast to the accumulator data type. The output of the adder remains in the accumulator data type as each element of the input is added to it. Use this parameter to specify how you would like to designate this accumulator word and fraction lengths.

- When you select `Same as product output`, these characteristics will match those of the product output.
- When you select `Binary point scaling`, you can enter the word length and the fraction length of the accumulator, in bits.
- When you select `Slope and bias scaling`, you can enter the word length, in bits, and the slope of the accumulator. The bias of all signals in the Video and Image Processing Blockset is zero.

## **Centroid output**

Choose how you will specify the word length and fraction length of the output at the Centroid port:

- When you select `Same as accumulator`, these characteristics will match those of the accumulator.
- When you select `Same as product output`, these characteristics will match those of the product output.
- When you select `Binary point scaling`, you can enter the word length and the fraction length of the output, in bits.
- When you select `Slope and bias scaling`, you can enter the word length, in bits, and the slope of the output. The bias of all signals in the Video and Image Processing Blockset is zero.

## **Equip Diam<sup>2</sup> output**

Choose how you will specify the word length and fraction length of the output at the Diameter<sup>2</sup> port:

- When you select `Same as accumulator`, these characteristics will match those of the accumulator.
- When you select `Same as product output`, these characteristics will match those of the product output.

- When you select Binary point scaling, you can enter the word length and the fraction length of the output, in bits.
- When you select Slope and bias scaling, you can enter the word length, in bits, and the slope of the output. The bias of all signals in the Video and Image Processing Blockset is zero.

## **Extent output**

Choose how you will specify the word length and fraction length of the output at the Extent port:

- When you select Same as accumulator, these characteristics will match those of the accumulator.
- When you select Same as product output, these characteristics will match those of the product output.
- When you select Binary point scaling, you can enter the word length and the fraction length of the output, in bits.
- When you select Slope and bias scaling, you can enter the word length, in bits, and the slope of the output. The bias of all signals in the Video and Image Processing Blockset is zero.

## **Lock scaling against changes by the autoscaling tool**

Select this parameter to prevent any fixed-point scaling you specify in this block mask from being overridden by the autoscaling tool in the Fixed-Point Settings interface. For more information about the autoscaling tool, refer to the Fixed-Point Settings Interface section of the Signal Processing Blockset User's Guide.

## **See Also**

Label	Video and Image Processing Blockset
Variable Selector	Signal Processing Blockset
regionprops	Image Processing Toolbox

# Block Processing

## Purpose

Repeat user-specified operation on submatrices of input matrix

## Library

Utilities

## Description

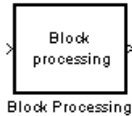

The Block Processing block extracts submatrices of a user-specified size from each input matrix. It sends each submatrix to a subsystem for processing, and then reassembles each subsystem output into the output matrix.

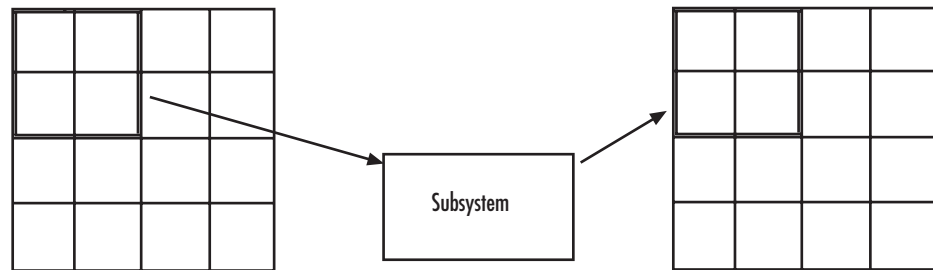

The blocks inside the subsystem dictate the frame status of the input and output signals, whether single channel or multichannel signals are supported, and which data types are supported by this block.

Use the **Number of inputs** and **Number of outputs** parameters to specify the number of input and output ports on the Block Processing block.

Use the **Block size** parameter to specify the size of each submatrix in cell array format. Each vector in the cell array corresponds to one input; the block uses the vectors in the order you enter them. If you have one input port, enter one vector. If you have more than one input port, you can enter one vector that is used for all inputs or you can specify a different vector for each input. For example, if you want each submatrix to be 2-by-3, enter `{[2 3]}`.

Use the **Overlap size** parameter to specify the overlap of each submatrix in cell array format. Each vector in the cell array corresponds to the overlap of one input; the block uses the vectors in the order they are specified. If you enter one vector, each overlap is the same size. For

example, if you want each 3-by-3 submatrix to overlap by 1 row and 2 columns, enter `{[1 2]}`.

The **Traverse order** parameter determines how the block extracts submatrices from the input matrix. If you select **Row-wise**, the block extracts submatrices by moving across the rows. If you select **Column-wise**, the block extracts submatrices by moving down the columns.

Click the **Open Subsystem** button to open the block's subsystem. Click-and-drag blocks into this subsystem to define the processing operation(s) the block performs on the submatrices. The input to this subsystem are the submatrices whose size is determined by the **Block size** parameter.

---

**Note** Because you modify the Block Processing block's subsystem, the link between this block and the block library is broken when you click-and-drag a Block Processing block into your model. As a result, this block will not be automatically updated if you upgrade to a newer version of the Video and Image Processing Blockset. If you right-click on the block and select **Look under mask**, you can delete blocks from this subsystem without triggering a warning. Lastly, if you search for library blocks in a model, this block will not be part of the results.

---

## Example

### Example 1 - Multiple Inputs

In this example, you multiply each element of three input matrices by two and add the results using the Block Processing block. Suppose you have the following model:

# Block Processing

---

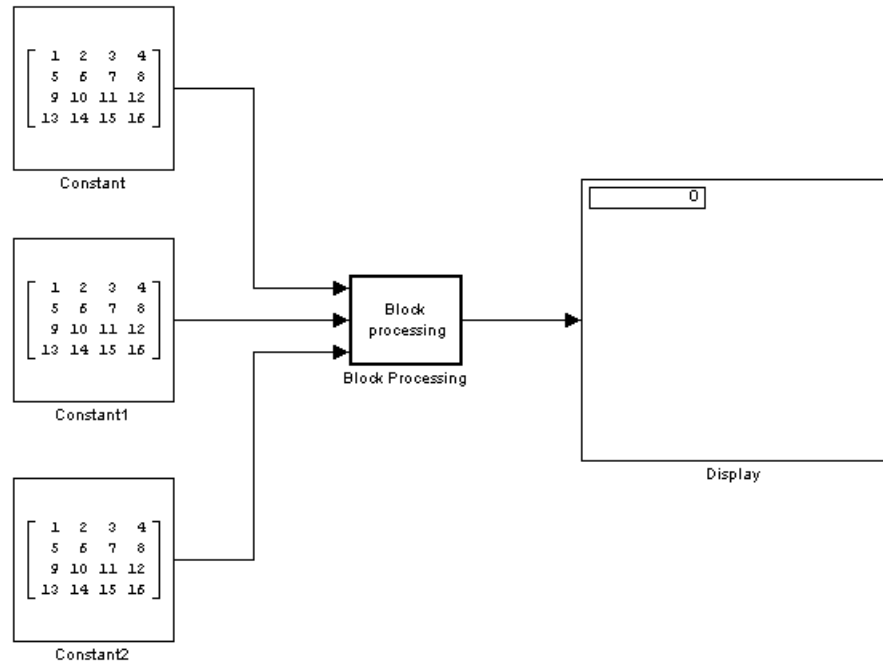

- 1 Use the Block Processing block to perform the multiplication and addition on submatrices of the three input matrices. Set the block parameters as follows:
  - **Number of inputs** = 3
  - **Number of outputs** = 1
  - **Block size** = {[2 2]}



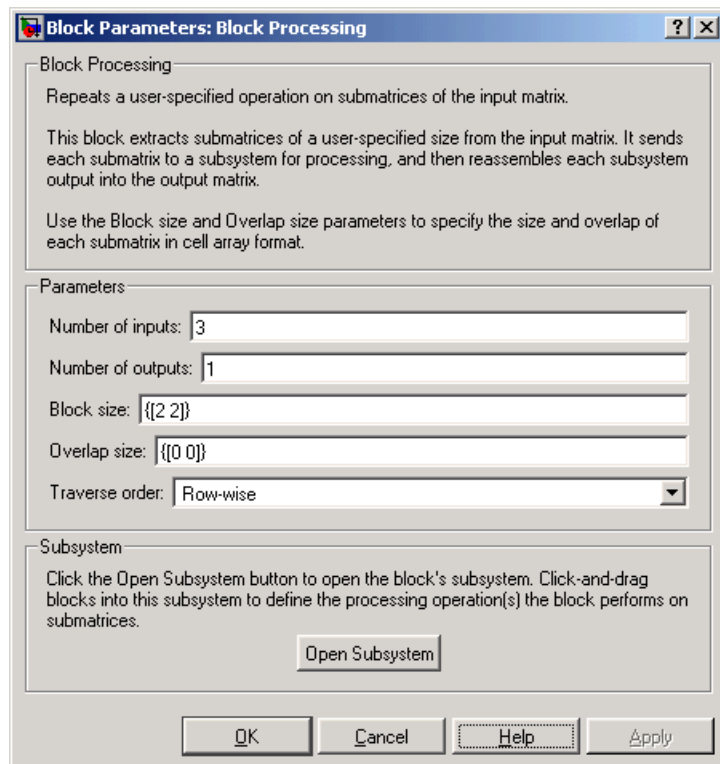

For each iteration, the block sends a 2-by-2 submatrix from each input matrix to the Block Processing blocks' subsystem to be processed. The block calculates its total number of iterations using the dimensions of the matrix connected to the top input port. In this case, the first input is a 4-by-4 matrix. Since the block can extract four 2-by-2 submatrices from this input matrix, the block iterates four times.

## 2 Click **Open Subsystem**.

The block's subsystem opens.

# Block Processing

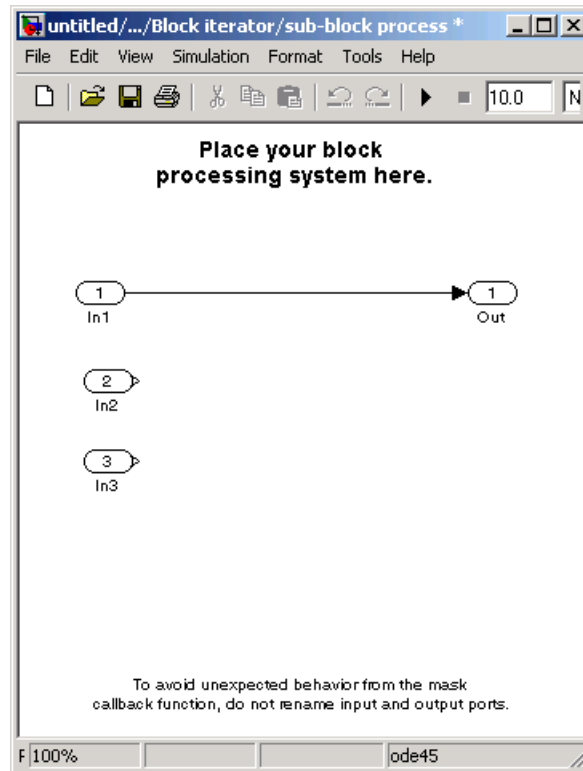

3 Click and drag the following blocks into the subsystem:

Block	Library	Quantity
Gain	Simulink / Math Operations	3
Sum	Simulink / Math Operations	1

- 4 Use the Gain blocks to multiply the elements of each submatrix by two. Set the **Gain** parameter to 2.
- 5 Use the Sum block to add the values. Set the **Icon shape** parameter to rectangular and the **List of signs** parameter to +++.

- 6 Connect the blocks as shown in the figure below.

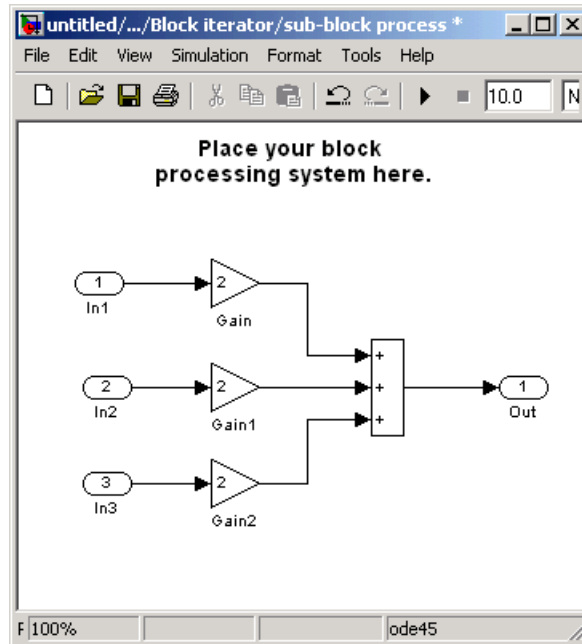

- 7 Close the subsystem and Click **OK**.
- 8 Run the model.

# Block Processing

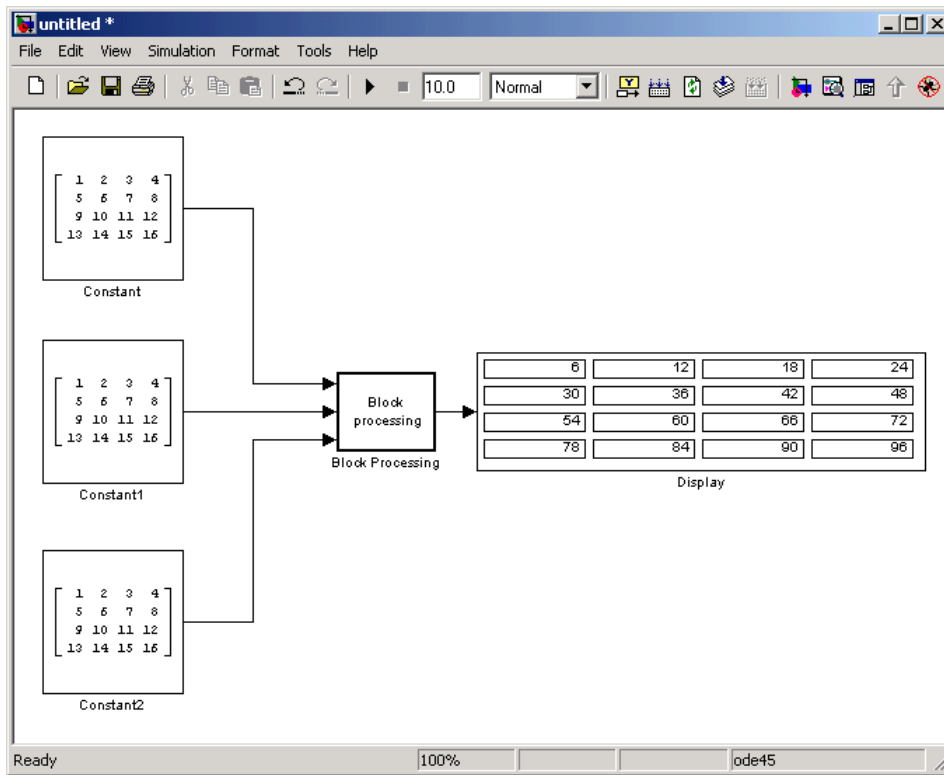

The Block Processing block operates on the submatrices and assembles the results into an output matrix that is displayed using the Display block.

## Dialog Box

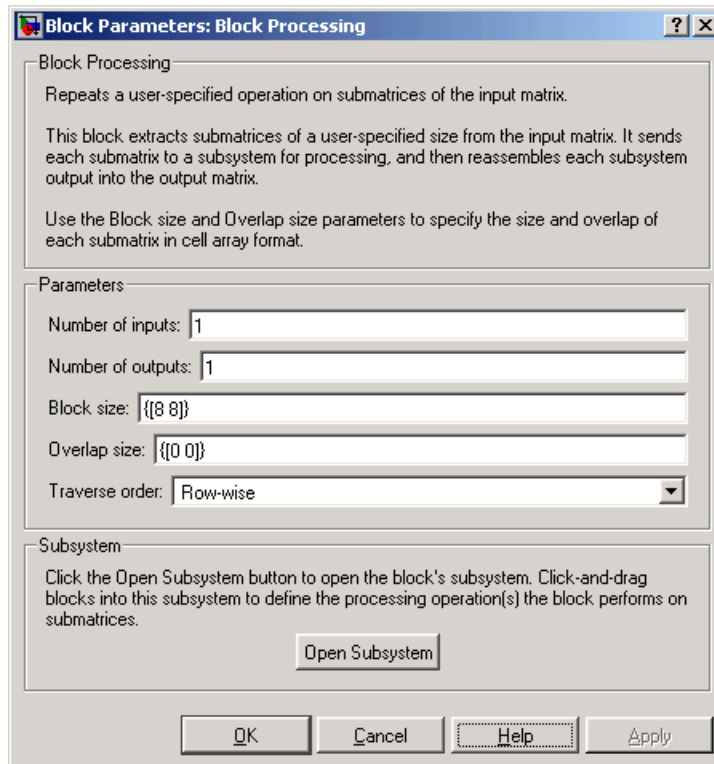

### Number of inputs

Enter the number of input ports on the Block Processing block.

### Number of outputs

Enter the number of output ports on the Block Processing block.

### Block size

Specify the size of each submatrix in cell array format. Each vector in the cell array corresponds to one input.

### Overlap size

Specify the overlap of each submatrix in cell array format. Each vector in the cell array corresponds to the overlap of one input.

# Block Processing

---

## **Traverse order**

Determines how the block extracts submatrices from the input matrix. If you select *Row-wise*, the block extracts submatrices by moving across the rows. If you select *Column-wise*, the block extracts submatrices by moving down the columns.

## **Open Subsystem**

Click this button to open the block's subsystem. Click-and-drag blocks into this subsystem to define the processing operation(s) the block performs on the submatrices.

## **See Also**

For Iterator

blkproc

Simulink

Image Processing Toolbox

**Purpose** Perform bottom-hat filtering on intensity or binary images

**Library** Morphological Operations

**Description** Use the Bottom-hat block to perform bottom-hat filtering on an intensity or binary image using a predefined neighborhood or structuring element. Bottom-hat filtering is the equivalent of subtracting the result of performing a morphological closing operation on the input image from the input image itself. This block uses flat structuring elements only.

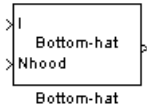

Port	Input/Output	Supported Data Types	Supports Complex Values?
I	Scalar, vector, or matrix of intensity values or scalar, vector, or matrix that represents one plane of the input RGB video stream	<ul style="list-style-type: none"> <li>• Double-precision floating point</li> <li>• Single-precision floating point</li> <li>• Fixed point</li> <li>• Boolean</li> <li>• 8-, 16-, and 32-bit signed integers</li> <li>• 8-, 16-, and 32-bit unsigned integers</li> </ul>	No
Nhood	Matrix or vector of ones and zeros that represents the neighborhood values	<ul style="list-style-type: none"> <li>• Boolean</li> </ul>	No
Output	Scalar, vector, or matrix that represents the filtered image	Same as I port	No

If your input image is a binary image, for the **Input image type** parameter, select Binary. If your input image is an intensity image, select Intensity.

Use the **Neighborhood or structuring element source** parameter to specify how you want to enter your neighborhood or structuring element values. If you select Specify via dialog, the **Neighborhood**

# Bottom-hat

**or structuring element** parameter appears on the dialog box. If you select Input port, the Nhood port appears on the block. Use this port to enter your neighborhood values as a matrix or vector of ones and zeros. You can only specify a structuring element using the dialog box.

Use the **Neighborhood or structuring element** parameter to define the region the block moves throughout the image. Specify a neighborhood by entering a matrix or vector of ones and zeros. Specify a structuring element with the `strel` function from the Image Processing Toolbox. If the structuring element is decomposable into smaller elements, the block executes at higher speeds due to the use of a more efficient algorithm.

## Dialog Box

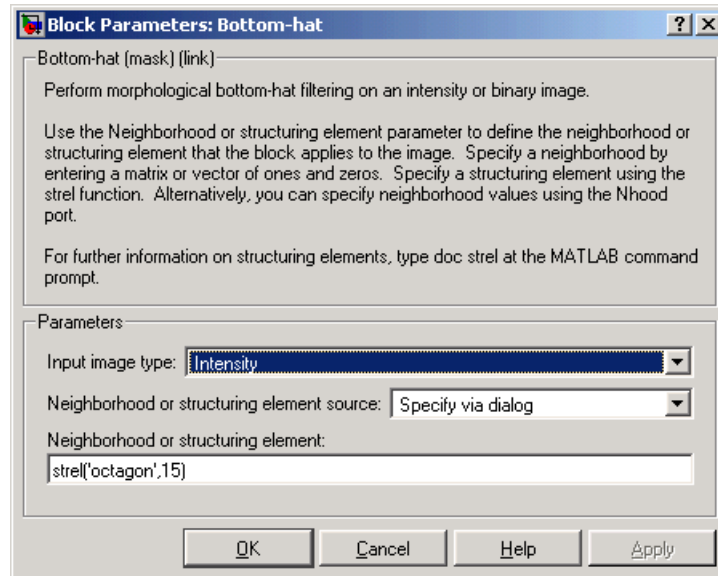

### Input image type

If your input image is a binary image, select Binary. If your input image is an intensity image, select Intensity.



## Neighborhood or structuring element source

Specify how you want to enter your neighborhood or structuring element values. Select `Specify via dialog` to enter the values in the dialog box. Select `Input port` to use the `Nhood` port to specify the neighborhood values. You can only specify a structuring element using the dialog box.

## Neighborhood or structuring element

If you are specifying a neighborhood, this parameter must be a matrix or vector of ones and zeros. If you are specifying a structuring element, use the `strel` function from the Image Processing Toolbox. This parameter is visible if, for the **Neighborhood or structuring element source** parameter, you select `Specify via dialog`.

## See Also

Closing	Video and Image Processing Blockset
Dilation	Video and Image Processing Blockset
Erosion	Video and Image Processing Blockset
Label	Video and Image Processing Blockset
Opening	Video and Image Processing Blockset
Top-hat	Video and Image Processing Blockset
<code>imbothat</code>	Image Processing Toolbox
<code>strel</code>	Image Processing Toolbox

# Chroma Resampling

**Purpose** Downsample or upsample chrominance components of images

**Library** Conversions

**Description** The Chroma Resampling block downsamples or upsamples chrominance components of pixels to reduce the bandwidth required for transmission or storage of a signal.

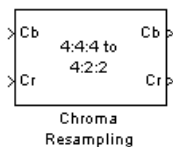

Port	Input/Output	Supported Data Types	Supports Complex Values?
Cb	Matrix that represents one chrominance component of an image	<ul style="list-style-type: none"><li>• Double-precision floating point</li><li>• Single-precision floating point</li><li>• 8-bit unsigned integers</li></ul>	No
Cr	Matrix that represents one chrominance component of an image	Same as Cb port	No

The data type of the output signals is the same as the data type of the input signals.

## Chroma Resampling Formats

The Chroma Resampling block supports the formats shown in the diagram below.

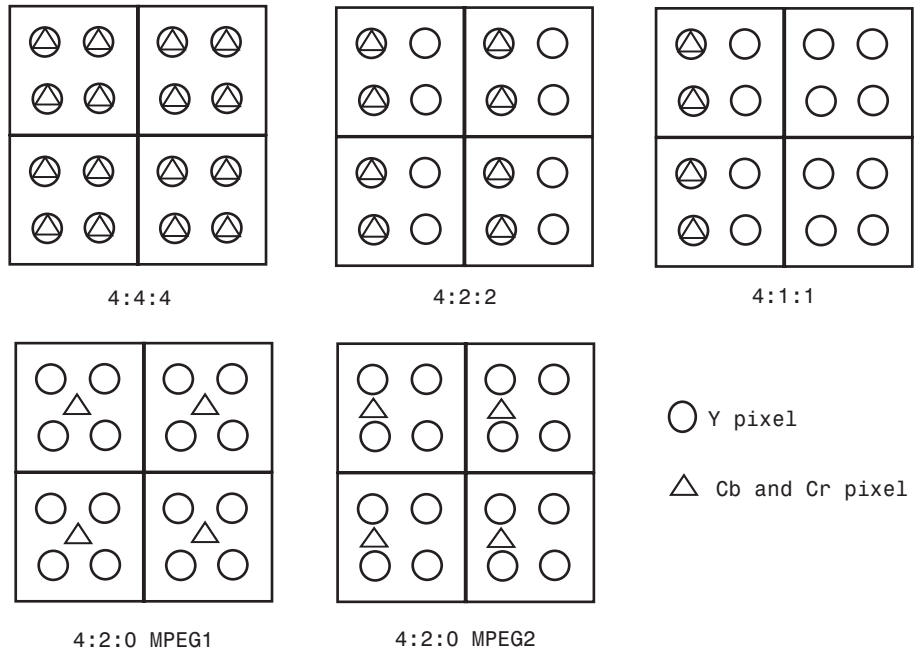

## Downsampling

If, for the **Resampling** parameter, you select 4:4:4 to 4:2:2, 4:4:4 to 4:2:0 (MPEG1), 4:4:4 to 4:2:0 (MPEG2), 4:4:4 to 4:1:1, 4:2:2 to 4:2:0 (MPEG1), or 4:2:2 to 4:2:0 (MPEG2), the block performs a downsampling operation. When the block downsamples from one format to another, it can bandlimit the input signal by applying a lowpass filter to prevent aliasing.

If, for the **Antialiasing filter** parameter, you select Default, the block uses a built-in lowpass filter to prevent aliasing.

If, for the **Resampling** parameter, you select 4:4:4 to 4:2:2, 4:4:4 to 4:2:0 (MPEG1), 4:4:4 to 4:2:0 (MPEG2), or 4:4:4 to 4:1:1 and, for the **Antialiasing filter** parameter, you select User-defined, the **Horizontal filter coefficients** parameter appears

# Chroma Resampling

on the dialog. Enter the filter coefficients you want to apply to your input.

If, for the **Resampling** parameter, you select 4:4:4 to 4:2:0 (MPEG1), 4:4:4 to 4:2:0 (MPEG2), 4:2:2 to 4:2:0 (MPEG1), or 4:2:2 to 4:2:0 (MPEG2) and, for the **Antialiasing filter** parameter, you select User-defined. **Vertical filter coefficients** parameters appear on the dialog. Enter an even number of filter coefficients to apply to your input signal.

If, for the **Antialiasing filter** parameter, you select None, the block does not filter the input signal.

## Upsampling

If, for the **Resampling** parameter, you select 4:2:2 to 4:4:4, 4:2:0 (MPEG1) to 4:2:2, 4:2:0 (MPEG1) to 4:4:4, 4:2:0 (MPEG2) to 4:2:2, 4:2:0 (MPEG2) to 4:4:4, or 4:1:1 to 4:4:4, the block performs an upsampling operation.

When the block upsamples from one format to another, it uses interpolation to approximate the missing chrominance values. If, for the **Interpolation** parameter, you select Linear, the block uses linear interpolation to calculate the missing values. If, for the **Interpolation** parameter, you select Pixel replication, the block replicates the chrominance values of the neighboring pixels to create the upsampled image.

## Dialog Box

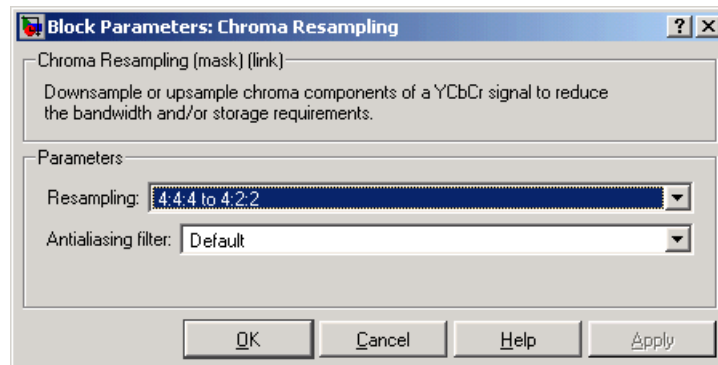

## Resampling

Specify the resampling format.

## Antialiasing filter

Specify the lowpass filter that the block uses to prevent aliasing. If you select **Default**, the block uses a built-in lowpass filter. If you select **User-defined**, the **Horizontal filter coefficients** and/or **Vertical filter coefficients** parameters appear on the dialog. If you select **None**, the block does not filter the input signal. This parameter is visible when you are downsampling the chrominance values.

## Horizontal filter coefficients

Enter the filter coefficients you want to apply to your input signal. This parameter is visible if, for the **Resampling** parameter, you select 4:4:4 to 4:2:2, 4:4:4 to 4:2:0 (MPEG1), 4:4:4 to 4:2:0 (MPEG2), or 4:4:4 to 4:1:1 and, for the **Antialiasing filter** parameter, you select **User-defined**.

## Vertical filter coefficients

Enter the filter coefficients you want to apply to your input signal. This parameter is visible if, for the **Resampling** parameter, you select 4:4:4 to 4:2:0 (MPEG1), 4:4:4 to 4:2:0 (MPEG2), 4:2:2 to 4:2:0 (MPEG1), or 4:2:2 to 4:2:0 (MPEG2) and, for the **Antialiasing filter** parameter, you select **User-defined**.

## Interpolation

Specify the interpolation method that the block uses to approximate the missing chrominance values. If you select **Linear**, the block uses linear interpolation to calculate the missing values. If you select **Pixel replication**, the block replicates the chrominance values of the neighboring pixels to create the upsampled image. This parameter is visible when you are upsampling the chrominance values.

## Reference

Haskell, Barry G., Atul Puri, and Arun N. Netravali. *Digital Video: An Introduction to MPEG-2*. New York: Chapman & Hall, 1996.

# Chroma Resampling

---

Recommendation ITU-R BT.601-5, Studio Encoding Parameters of Digital Television for Standard 4:3 and Wide Screen 16:9 Aspect Ratios.

Wang, Yao, Jorn Ostermann, Ya-Qin Zhang. *Video Processing and Communications*. Upper Saddle River, NJ: Prentice Hall, 2002.

## See Also

Autothreshold	Video and Image Processing Blockset
Color Space Conversion	Video and Image Processing Blockset
Image Complement	Video and Image Processing Blockset

**Purpose** Perform morphological closing on binary or intensity images

**Library** Morphological Operations

**Description** The Closing block performs a dilation operation followed by an erosion operation using a predefined neighborhood or structuring element. This block uses flat structuring elements only.

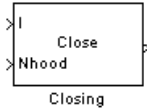

Port	Input/Output	Supported Data Types	Supports Complex Values?
I	Vector or matrix of intensity values	<ul style="list-style-type: none"> <li>• Double-precision floating point</li> <li>• Single-precision floating point</li> <li>• Fixed point</li> <li>• Boolean</li> <li>• 8-, 16-, and 32-bit signed integers</li> <li>• 8-, 16-, and 32-bit unsigned integers</li> </ul>	No
Nhood	Matrix or vector of ones and zeros that represents the neighborhood values	<ul style="list-style-type: none"> <li>• Boolean</li> </ul>	No
Output	Vector or matrix of intensity values that represents the closed image	Same as I port	No

The output signal has the same data type as the input to the I port. This block supports a signal represented by a Simulink virtual bus.

Use the **Neighborhood or structuring element source** parameter to specify how you want to enter your neighborhood or structuring

# Closing

element values. If you select Specify via dialog, the **Neighborhood or structuring element** parameter appears on the dialog box. If you select Input port, the Nhood port appears on the block. Use this port to enter your neighborhood values as a matrix or vector of ones and zeros. You can only specify a structuring element using the dialog box.

Use the **Neighborhood or structuring element** parameter to define the region the block moves throughout the image. Specify a neighborhood by entering a matrix or vector of ones and zeros. Specify a structuring element with the `strel` function from the Image Processing Toolbox. If the structuring element is decomposable into smaller elements, the block executes at higher speeds due to the use of a more efficient algorithm.

## Dialog Box

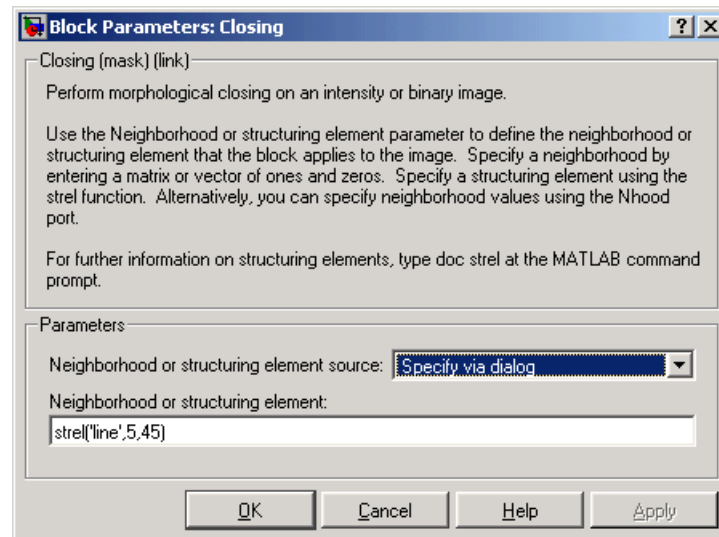

### Neighborhood or structuring element source

Specify how you want to enter your neighborhood or structuring element values. Select Specify via dialog to enter the values in the dialog box. Select Input port to use the Nhood port to specify



the neighborhood values. You can only specify a structuring element using the dialog box.

### **Neighborhood or structuring element**

If you are specifying a neighborhood, this parameter must be a matrix or vector of ones and zeros. If you are specifying a structuring element, use the `strel` function from the Image Processing Toolbox. This parameter is visible if, for the **Neighborhood or structuring element source** parameter, you select Specify via dialog.

### **References**

Soille, Pierre. *Morphological Image Analysis. 2nd ed.* New York: Springer, 2003.

### **See Also**

Bottom-hat	Video and Image Processing Blockset
Dilation	Video and Image Processing Blockset
Erosion	Video and Image Processing Blockset
Label	Video and Image Processing Blockset
Opening	Video and Image Processing Blockset
Top-hat	Video and Image Processing Blockset
<code>imclose</code>	Image Processing Toolbox
<code>strel</code>	Image Processing Toolbox

# Color Space Conversion

**Purpose** Convert color information between R'G'B' and Y'CbCr and from R'G'B' to intensity

**Library** Conversions

**Description** The Color Space Conversion block converts color information from the R'G'B' color space to the Y'CbCr color space, from the Y'CbCr color space to the R'G'B' color space, and from the R'G'B' color space to intensity. Use the **Conversion** parameter to specify the color spaces you are converting between.

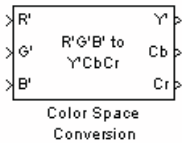

Port	Input/Output	Supported Data Types	Supports Complex Values?
R'	Matrix that represents one plane of the input RGB video stream	<ul style="list-style-type: none"> <li>• Double-precision floating point</li> <li>• Single-precision floating point</li> <li>• 8-bit unsigned integers</li> </ul>	No
G'	Matrix that represents one plane of the input RGB video stream	Same as the R' port	No
B'	Matrix that represents one plane of the input RGB video stream	Same as the R' port	No

# Color Space Conversion

Port	Input/Output	Supported Data Types	Supports Complex Values?
Y	Matrix that represents the luma portion of an image	Same as the R' port	No
Cb	Matrix that represents one chrominance component of an image	Same as the R' port	No
Cr	Matrix that represents one chrominance component of an image	Same as the R' port	No
I'	Matrix of intensity values	Same as the R' port	No

The data type of the output signal is the same as the data type of the input signal.

---

**Note** The prime notation indicates that the signals are gamma corrected.

---

The R'G'B' to YCbCr conversion and the YCbCr to R'G'B' conversion are defined by the following equations, respectively. These equations are derived from the Recommendation ITU-R BT.601-5 specification:

$$\begin{bmatrix} Y' \\ Cb \\ Cr \end{bmatrix} = \begin{bmatrix} 16 \\ 128 \\ 128 \end{bmatrix} + \begin{bmatrix} 0.25678824 & 0.50412941 & 0.09790588 \\ -0.1482229 & -0.29099279 & 0.43921569 \\ 0.43921569 & -0.36778831 & -0.07142737 \end{bmatrix} \times \begin{bmatrix} R' \\ G' \\ B' \end{bmatrix}$$

# Color Space Conversion

$$\begin{bmatrix} R' \\ G' \\ B' \end{bmatrix} = \begin{bmatrix} 1.1643836 & 0 & 1.5960268 \\ 1.1643836 & -0.39176229 & -0.81296765 \\ 0.16438356 & 2.0172321 & 0 \end{bmatrix} \times \left( \begin{bmatrix} Y' \\ Cb \\ Cr \end{bmatrix} - \begin{bmatrix} 16 \\ 128 \\ 128 \end{bmatrix} \right)$$

The conversion from the R'B'G' color space to intensity is defined by the following equation:

$$\text{intensity} = \begin{bmatrix} 0.299 & 0.587 & 0.114 \end{bmatrix} \begin{bmatrix} R' \\ G' \\ B' \end{bmatrix}$$

## Dialog Box

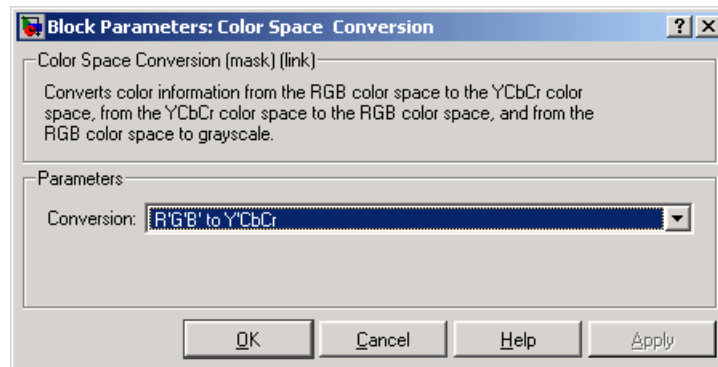

## Conversion

Specify the color spaces you are converting between. Your choices are R'G'B' to Y'CbCr, Y'CbCr to R'G'B', or R'G'B' to intensity.

## Reference

Poynton, Charles A. *A Technical Introduction to Digital Video*. New York: John Wiley & Sons, 1996.

## See Also

Autothreshold

Video and Image Processing Blockset

Chroma Resampling

Video and Image Processing Blockset

Image Complement

Video and Image Processing Blockset

# Compositing

**Purpose** Combine pixel values of two images or overlay one image over another

**Library** Text & Graphics

**Description** You can use the Compositing block to combine two images, where each pixel of the output image is a linear combination of the pixels in each input image. This process is defined by the following equation:

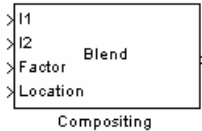

$$O(i, j) = (1 - X) * I1(i, j) + X * I2(i, j)$$

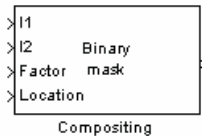

The opacity factor,  $X$ , where  $0 \leq X \leq 1$ , defines the amount by which to scale each pixel value before combining them.

You can also use the Compositing block to overlay a  $I2$  over  $I1$ . The masking factor and the location determine which  $I1$  pixels are overwritten. The masking factor(s) can be 0 or 1, where 0 corresponds to not overwriting pixels and 1 corresponds to overwriting pixels.

Port	Input/Output	Supported Data Types	Supports Complex Values?
I1	Scalar, vector, or matrix of intensity values	<ul style="list-style-type: none"> <li>• Double-precision floating point</li> <li>• Single-precision floating point</li> <li>• Fixed point</li> <li>• Boolean</li> <li>• 8-, 16-, and 32-bit signed integers</li> <li>• 8-, 16-, and 32-bit unsigned integers</li> </ul>	No
I2	Scalar, vector, or matrix of intensity values	Same as I1 port	No

Port	Input/Output	Supported Data Types	Supports Complex Values?
Factor	Scalar or matrix of opacity or masking factor	<ul style="list-style-type: none"> <li>• Double-precision floating point</li> <li>• Single-precision floating point</li> <li>• Fixed point</li> <li>• Boolean</li> <li>• 8-, 16-, and 32-bit signed integers</li> <li>• 8-, 16-, and 32-bit unsigned integers</li> </ul>	No
Location	Two-element vector that specifies the position of the upper left corner of the image input at port I2	<ul style="list-style-type: none"> <li>• Double-precision floating point</li> <li>• Single-precision floating point</li> <li>• Boolean</li> <li>• 8-, 16-, and 32-bit signed integers</li> <li>• 8-, 16-, and 32-bit unsigned integers</li> </ul>	No
Output	Scalar, vector, or matrix of intensity values	Same as I1 port	No

Use the **Operation** parameter to specify the operation you want the block to perform. If you choose **Blend**, the block linearly combines the pixels of one image with another image. If you choose **Binary mask**, the block overwrites the pixel values of one image with the pixel values of another image.

If, for the **Operation** parameter, you choose **Blend**, the **Opacity factor(s) source** parameter appears on the dialog. Use this parameter

to indicate where you want to specify the opacity factor(s). If you choose Specify via dialog, the **Opacity factor(s)** parameter appears on the dialog. Use this parameter to define the amount by which the block scales each I2 pixel value before combining them with the I1 pixel values. You can enter a scalar value used for all pixels or a matrix of values that is the same size as I2. If, for the **Opacity factor(s) source** parameter, you choose Input port, the Factor port appears on the block. The input to this port must be a scalar or matrix of values as described for the **Opacity factor(s)** parameter. If the input to the I1 and I2 ports is floating point, the input to this port must be the same floating-point data type.

If, for the **Operation** parameter, you choose Binary mask, the **Masking factor(s) source** parameter appears on the dialog. Use this parameter to indicate where you want to specify the masking factor(s). If you choose Specify via dialog, the **Masking factor(s)** parameter appears on the dialog. Use this parameter and the location of the I2 image to define which pixels are overwritten. You can enter 0 or 1, which is used for all pixels in I2, or a matrix of 0's and 1's that defines the factor for each I2 pixel. If, for the **Masking factor(s) source** parameter, you choose Input port, the Factor port appears on the block. The input to this port must be a 0 or 1 whose data type is Boolean or a matrix of 0's or 1's whose data type is Boolean as described for the **Masking factor(s)** parameter.

Use the **Location source** parameter to specify where you want to enter the zero-based location of the upper left corner of the image input at port I2. If you choose Specify via dialog, the **Location [row column]** parameter appears on the dialog. Enter a two-element vector that specifies the row and column position of the upper left corner of the image input at port I2 relative to the upper left corner of the image input at port I1. Positive values move the image down and to the right; negative images move the image up and to the left. If the first element is greater than the number of rows in the I1 matrix, the value is clipped to the total number of rows. If the second element is greater than the number of columns in the I1 matrix, the value is clipped to the total number of columns. If, for the **Location source** parameter, you choose Input port, the Location port appears on the block. The input to this



port must be a two-element vector as described for the **Location [row column]** parameter.

## Fixed-Point Data Types

The following diagram shows the data types used within the Compositing block for fixed-point signals. It is only applicable when the **Operation** parameter is set to Blend.

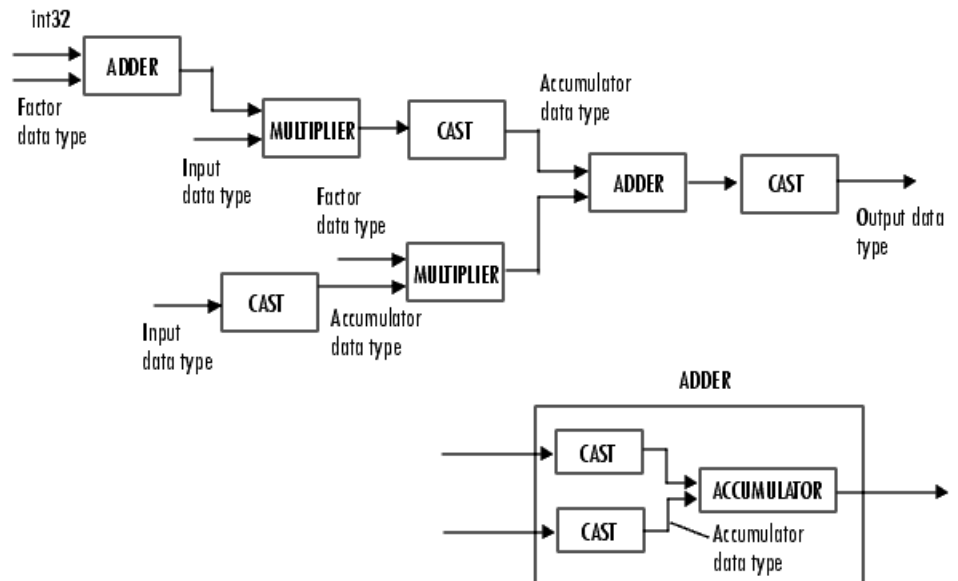

You can set the product output, accumulator, and output data types in the block mask as discussed below.

# Compositing

## Dialog Box

The **Main** pane of the Compositing block dialog appears as follows:

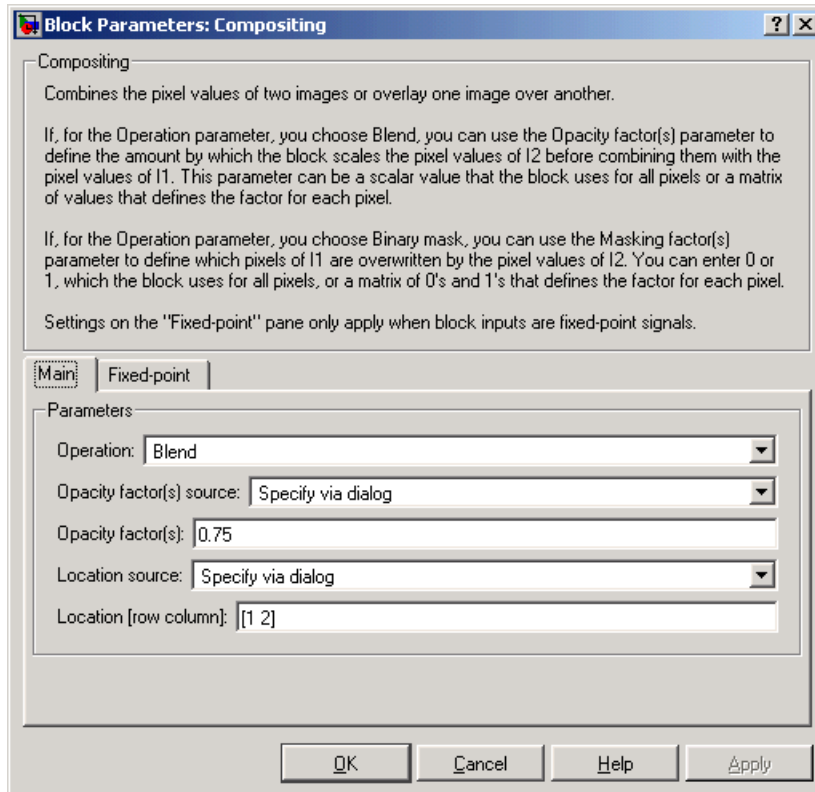

### Operation

Specify the operation you want the block to perform. If you choose **Blend**, the block linearly combines the pixels of one image with another image. If you choose **Binary mask**, the block overwrites the pixel values of one image with the pixel values of another image.

## **Opacity factor(s) source**

Indicate where you want to specify the opacity factor(s). Your choices are Specify via dialog and Input port. This parameter is visible if, for the **Operation** parameter you choose Blend.

## **Opacity factor(s)**

Define the amount by which the block scales each pixel value before combining them. You can enter a scalar value used for all pixels or a matrix of values that defines the factor for each pixel. This parameter is visible if, for the **Opacity factor(s) source** parameter you choose Specify via dialog. Tunable.

## **Masking factor(s) source**

Indicate where you want to specify the masking factor(s). Your choices are Specify via dialog and Input port. This parameter is visible if, for the **Operation** parameter you choose Binary mask.

## **Masking factor(s)**

Define which pixels are overwritten. You can enter 0 or 1, which is used for all pixels, or a matrix of 0's and 1's that defines the factor for each pixel. This parameter is visible if, for the **Masking factor(s) source** parameter you choose Specify via dialog. Tunable.

## **Location source**

Use this parameter to specify where you want to enter the location of the upper left corner of the image input at port I2. Your choices are Specify via dialog and Input port.

## **Location [row column]**

Enter a two-element vector that specifies the row and column position of the upper left corner of the image input at port I2 relative to the upper left corner of the image input at port I1. This parameter is visible if, for the **Location source** parameter you choose Specify via dialog. Tunable.

# Compositing

The **Fixed-point** pane of the Compositing block dialog box appears as follows. These parameters are applicable only when the **Operation** parameter is set to Blend.

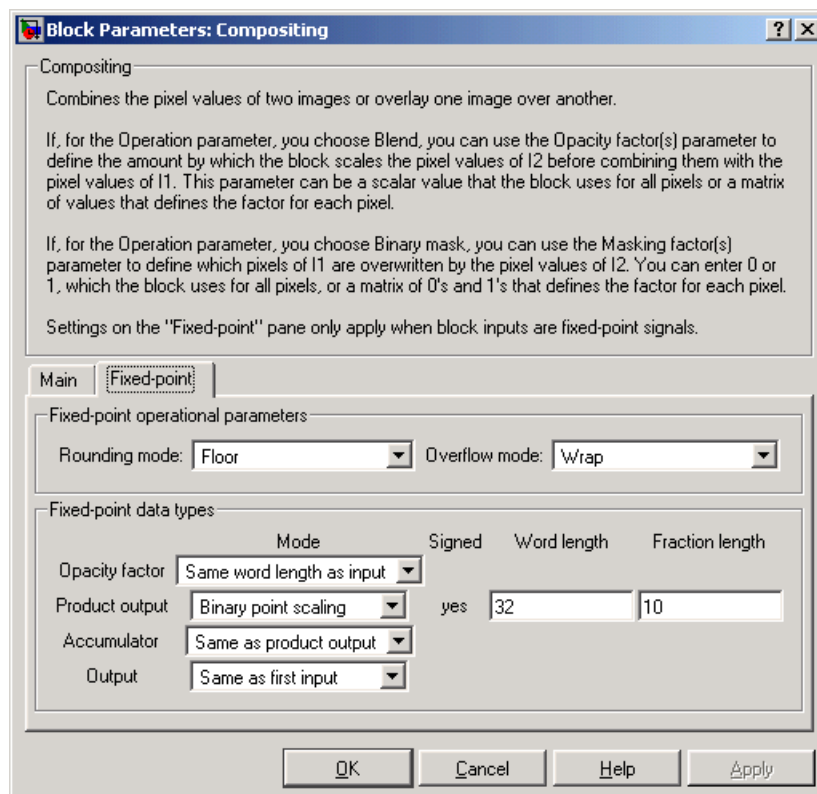

## Rounding mode

Select the rounding mode for fixed-point operations.

## Overflow mode

Select the overflow mode for fixed-point operations.

## Product output



As depicted above, the output of the multiplier is placed into the product output data type and scaling. Use this parameter to specify how you would like to designate this product output word and fraction lengths.

- When you select Same as first input, these characteristics will match those of the input to the block.
- When you select Binary point scaling, you can enter the word length and the fraction length of the product output, in bits.
- When you select Slope and bias scaling, you can enter the word length, in bits, and the slope of the product output. The bias of all signals in the Signal Processing Blockset is zero.

## Accumulator

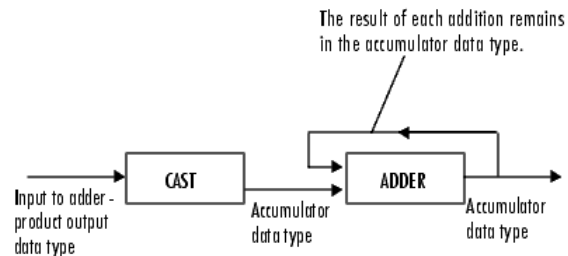

As depicted above, inputs to the accumulator are cast to the accumulator data type. The output of the adder remains in the accumulator data type as each element of the input is added to

it. Use this parameter to specify how you would like to designate this accumulator word and fraction lengths.

- When you select `Same as product output`, these characteristics will match those of the product output.
- When you select `Same as first input`, these characteristics will match those of the input to the block.
- When you select `Binary point scaling`, you can enter the word length and the fraction length of the accumulator, in bits.
- When you select `Slope and bias scaling`, you can enter the word length, in bits, and the slope of the accumulator. The bias of all signals in the Signal Processing Blockset is zero.

## Output

Choose how you will specify the word length and fraction length of the output of the block:

- When you select `Same as first input`, these characteristics will match those of the input to the block.
- When you select `Binary point scaling`, you can enter the word length and the fraction length of the output, in bits.
- When you select `Slope and bias scaling`, you can enter the word length, in bits, and the slope of the output. The bias of all signals in the Signal Processing Blockset is zero.

## See Also

[Insert Text](#)

[Video and Image Processing Blockset](#)

## Purpose

Find local maxima in binary or intensity images

## Library

Morphological Operations

## Description



The Dilation block rotates the neighborhood or structuring element 180 degrees. Then it slides the neighborhood or structuring element over an image, finds the local maxima, and creates the output matrix from these maximum values. If the neighborhood or structuring element has a center element, the block places the maxima there, as illustrated below.

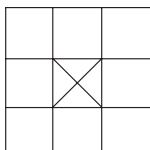

If the neighborhood or structuring element does not have an exact center, the block has a bias toward the lower right corner, as a result of the rotation. The block places the maxima there, as illustrated below.

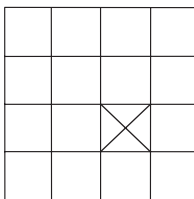

This block uses flat structuring elements only.

# Dilation

Port	Input/Output	Supported Data Types	Supports Complex Values?
I	Vector or matrix of intensity values	<ul style="list-style-type: none"> <li>• Double-precision floating point</li> <li>• Single-precision floating point</li> <li>• Fixed point</li> <li>• Boolean</li> <li>• 8-, 16-, and 32-bit signed integers</li> <li>• 8-, 16-, and 32-bit unsigned integers</li> </ul>	No
Nhood	Matrix or vector of ones and zeros that represents the neighborhood values	<ul style="list-style-type: none"> <li>• Boolean</li> </ul>	No
Output	Vector or matrix of intensity values that represents the dilated image	Same as I port	No

The output signal has the same data type as the input to the I port. This block supports a signal represented by a Simulink virtual bus.

Use the **Neighborhood or structuring element source** parameter to specify how you want to enter your neighborhood or structuring element values. If you select Specify via dialog, the **Neighborhood or structuring element** parameter appears on the dialog box. If you select Input port, the Nhood port appears on the block. Use this port to enter your neighborhood values as a matrix or vector of ones and zeros. You can only specify a structuring element using the dialog box.

Use the **Neighborhood or structuring element** parameter to define the neighborhood or structuring element that the block applies to the image. Specify a neighborhood by entering a matrix or vector of ones and zeros. Specify a structuring element with the strel function from the



Image Processing Toolbox. If the structuring element is decomposable into smaller elements, the block executes at higher speeds due to the use of a more efficient algorithm. If you enter an array of STREL objects, the block applies each object to the entire matrix in turn.

## Dialog Box

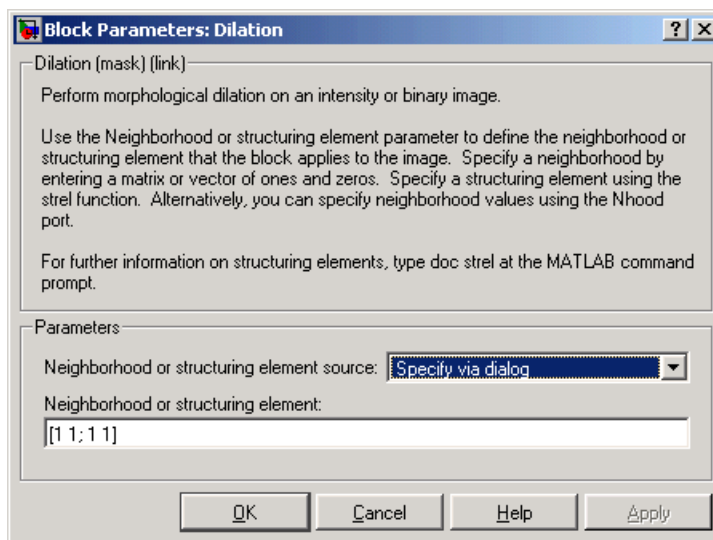

### Neighborhood or structuring element source

Specify how you want to enter your neighborhood or structuring element values. Select *Specify via dialog* to enter the values in the dialog box. Select *Input port* to use the Nhood port to specify the neighborhood values. You can only specify a structuring element using the dialog box.

### Neighborhood or structuring element

If you are specifying a neighborhood, this parameter must be a matrix or vector of ones and zeros. If you are specifying a structuring element, use the *strel* function from the Image Processing Toolbox. This parameter is visible if, for the **Neighborhood or structuring element source** parameter, you select *Specify via dialog*.

# Dilation

---

## References

Soille, Pierre. *Morphological Image Analysis. 2nd ed.* New York: Springer, 2003.

## See Also

Bottom-hat	Video and Image Processing Blockset
Closing	Video and Image Processing Blockset
Erosion	Video and Image Processing Blockset
Label	Video and Image Processing Blockset
Opening	Video and Image Processing Blockset
Top-hat	Video and Image Processing Blockset
imdilate	Image Processing Toolbox
strel	Image Processing Toolbox

**Purpose** Mark locations by drawing circles, x-marks, plus signs, stars, or squares

**Library** Text & Graphics

**Description** The Draw Markers block can draw multiple circles, x-marks, plus signs, stars, or squares on images by overwriting pixel values. As a result, the shapes are embedded on the output image.

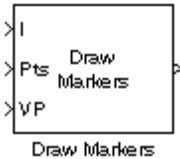

Port	Input/Output	Supported Data Types	Supports Complex Values?
I	Scalar, vector, or matrix of intensity values	<ul style="list-style-type: none"> <li>• Double-precision floating point</li> <li>• Single-precision floating point</li> <li>• Fixed point</li> <li>• Boolean</li> <li>• 8-, 16-, and 32-bit signed integers</li> <li>• 8-, 16-, and 32-bit unsigned integers</li> </ul>	No
R, G, B	Scalar, vector, or matrix that represents one plane of the input RGB video stream. Inputs to the R, G, and B ports must have the same dimensions and data type.	Same as I port	No

# Draw Markers

Port	Input/Output	Supported Data Types	Supports Complex Values?
Pts	2-by-N matrix of row and column pairs, $\begin{bmatrix} r_1 & r_2 & \cdots & r_N \\ c_1 & c_2 & \cdots & c_N \end{bmatrix}$ where N is the total number of markers and each row and column pair defines the center of a marker.	<ul style="list-style-type: none"> <li>• Double-precision floating point</li> <li>• Single-precision floating point</li> <li>• 8-, 16-, and 32-bit signed integers</li> <li>• 8-, 16-, and 32-bit unsigned integers</li> </ul>	No
VP	Four-element vector of integers that define a rectangular area in which you want to draw the shapes. The first two elements represent the zero-based row and column coordinates of the upper left corner of the area. The second two elements represent the height and width of the area.	<ul style="list-style-type: none"> <li>• Double-precision floating point</li> <li>• Single-precision floating point</li> <li>• 8-, 16-, and 32-bit signed integers</li> <li>• 8-, 16-, and 32-bit unsigned integers</li> </ul>	No
Output	Scalar, vector, or matrix of pixel values that contain the shape(s)	Same as I port	No

The output signal is the same size and data type as the inputs to the I, R, G, and B ports.

Use the **Input image type** parameter to specify the type of image input to the block. Your choices are Intensity or RGB.

Use the **Marker shape** parameter to specify the shape of the markers. Your choices are Circle, X-mark, Plus, Star, or Square.

Use the **Marker size** parameter to define the size of the marker, in pixels. Enter a scalar, M, that defines a 2M-by-2M pixel square into which the marker fits.

Use the **Draw markers in** parameter to define the area in which to draw the markers. If you select *Entire image*, you can draw markers in the entire image. If you select *Specify region of interest via port*, the VP port appears on the block. Enter a four-element vector of integer values,  $[r\ c\ height\ width]$ , where  $r$  and  $c$  are the row and column coordinates of the upper left corner of the area, and  $height$  and  $width$  represent the height (in rows) and width (in columns) of the area. If you specify values that are outside the image, the block clips the values to the image boundaries.

## Intensity Images

Use the **Intensity** parameter to specify the appearance of the markers. If you select *Black*, the marker border is black. If you select *White*, the marker border is white. If you select *User-specified value*, the **Intensity value** parameter appears on the dialog box. Enter a scalar intensity value between the minimum and maximum values that can be represented by the data type of the input image. The minimum value corresponds to black and the maximum value corresponds to white. If you enter a value outside this range, the block produces an error. You can specify a separate intensity value for each marker by entering a vector of intensities that is the same length as the total number of markers.

If you select the **Filled** check box, the **Intensity** parameter controls the appearance of the border and interior of the marker. Use the **Opacity factor (between 0 and 1)** parameter to specify the opacity of the shading inside the marker, where 0 is transparent and 1 is opaque.

---

**Note** If you are generating code and you select the **Filled** check box, the word length of the block input(s) must be less than or equal to 16-bits.

---

## Color Images

Use the **Intensity** parameter to specify the appearance of the markers. If you select *Black*, the marker border is black. If you select *White*, the

# Draw Markers

---

marker border is white. If you select User-specified value, the **RGB values** parameter appears on the dialog box. Enter a three-element vector of values between the minimum and maximum values that can be represented by the data type of the input image. The minimum value corresponds to an absence of color and the maximum value corresponds to the saturation of color. If you enter a value outside the data type range, the block produces an error. You can specify a separate RGB triplet for each shape by entering a 3-by-N matrix, where N is the total number of shapes.

If you select the **Filled** check box, the **Intensity** parameter controls the appearance of the border and interior of the marker. Use the **Opacity factor (between 0 and 1)** parameter to specify the opacity of the shading inside the marker, where 0 is transparent and 1 is opaque.

---

**Note** If you are generating code and you select the **Filled** check box, the word length of the block input(s) must be less than or equal to 16-bits.

---

## Dialog Box

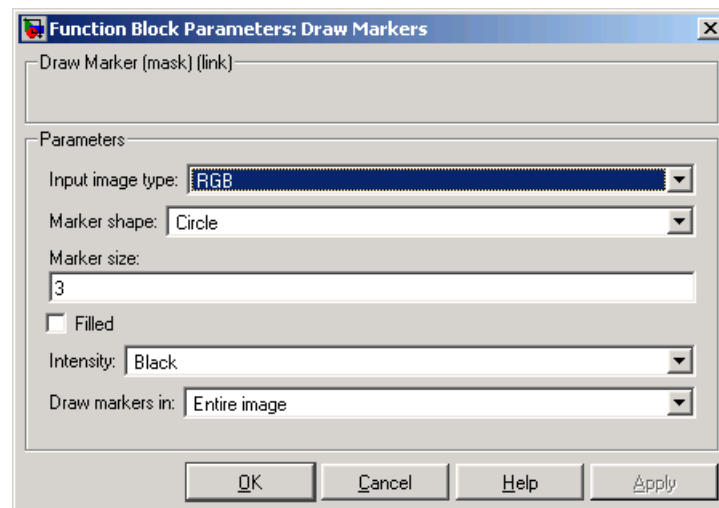

**Input image type**

Specify the type of image input to the block. Your choices are Intensity or RGB.

**Marker shape**

Specify the type of marker(s) to draw. Your choices are Circle, X-mark, Plus, Star, or Square.

**Marker size**

Enter a scalar that represents the size of the marker, in pixels.

**Filled**

Select this check box to fill the marker with an intensity value or a color. This parameter is visible if, for the **Marker shape** parameter, you choose Circle or Square.

**Intensity**

Specify the appearance of the marker. If you select Black, the marker border is black. If you select White, the marker border is white. If you select User-specified value, either the **Intensity value** or the **RGB values** parameter appears on the dialog box. If you select the **Filled** check box, this parameter controls the appearance of the border and interior of each marker.

**Intensity value**

Enter a scalar intensity value for the interior of the marker. This value must be between the minimum and maximum values that can be represented by the data type of the input image. The minimum value corresponds to black and the maximum value corresponds to white. This parameter is visible if, for the **Input image type** parameter, you select Intensity and, for the **Intensity** parameter, you select User-specified value. Tunable.

**RGB values**

Enter a three-element vector of values between the minimum and maximum values that can be represented by the data type of the input image. The minimum value corresponds to an absence of color and the maximum value corresponds to the saturation of color. This parameter is visible if, for the **Input image type**

# Draw Markers

---

parameter, you select RGB and, for the **Intensity** parameter, you select User-specified value. Tunable.

## **Opacity factor (between 0 and 1)**

Specify the opacity of the shading inside the marker, where 0 is transparent and 1 is opaque. This parameter is visible if you select the **Filled** check box. Tunable.

## **Draw markers in**

Define the area in which to draw the markers. If you select Entire image, you can draw marker in the entire image. If you select Specify region of interest via port, the VP port appears on the block. Enter a four-element vector, [r c height width], where r and c are the row and column coordinates of the upper left corner of the area, and height and width represent the height (in rows) and width (in columns) of the area.

## **See Also**

Draw Shapes

Video and Image Processing  
Blockset

Insert Text

Video and Image Processing  
Blockset



# Draw Shape (Obsolete)

**Purpose** Draw rectangle around region of interest (ROI)

**Library** vipobslib

## Description

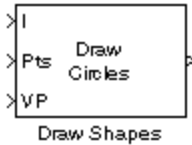

The Draw Shape block is obsolete. It may be removed in a future version of the Video and Image Processing Blockset. Use the replacement block Draw Shapes.

The Draw Shape block draws a rectangle around a user-defined ROI by overwriting pixel values. As a result, the rectangle is embedded on the output image.

Port	Input/Output	Supported Data Types	Supports Complex Values?
I	Scalar, vector, or matrix of intensity values or scalar, vector, or matrix that represents one plane of the input RGB video stream	<ul style="list-style-type: none"><li>• Double-precision floating point</li><li>• Single-precision floating point</li><li>• Fixed point</li><li>• Boolean</li></ul>	No
ROI	Four-element vector of integers. The first two elements represent the zero-based row and column coordinates of the upper left corner of the ROI. The second two elements represent the height and width of the ROI.	<ul style="list-style-type: none"><li>• Double-precision floating point</li><li>• Single-precision floating point</li><li>• 8-, 16-, and 32-bit signed integers</li><li>• 8-, 16-, and 32-bit unsigned integers</li></ul>	No
Output	Scalar, vector, or matrix of pixel values that contains the region of interest	Same as I port	No

## Draw Shape (Obsolete)

---

The output signal is the same size and data type as the input to the I port. This block supports a signal represented by the Simulink virtual bus.

Use the **Display intensity** parameter to determine the appearance of the ROI rectangle. If you select *Black* or *White*, the rectangle is black or white, respectively. If you select *Black and white (2 lines)*, the rectangle is created by a black line on the outside and a white line on the inside. If you select *User-specified intensity*, the **Intensity value (0 to 1)** parameter appears on the dialog box. Enter a scalar intensity value from 0 to 1, where 0 corresponds to black and 1 corresponds to white.

Use the **ROI source** parameter to determine how you want to enter your ROI coordinates. If you select *Specify via dialog*, the **ROI [row column height width]** parameter appears on the dialog. Enter a four-element vector of integers. The first two elements represent the zero-based row and column coordinates of the upper left corner of the ROI. The second two elements represent the height and width of the ROI. If you select *Input port*, the ROI port appears on the dialog. The input to this port must be a four-element of integers as defined above.

## Dialog Box

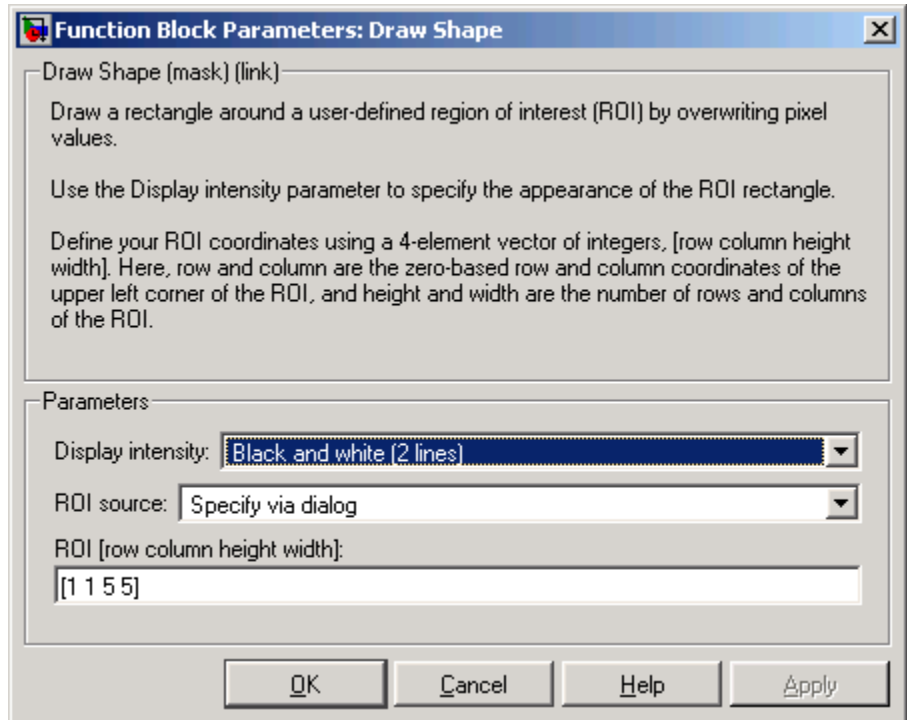

### Display intensity

Specify the appearance of the ROI rectangle. If you select **Black** or **White**, the rectangle is black or white. If you select **Black and white (2 lines)**, the rectangle is created by a black line on the outside and a white line on the inside. If you select **User-specified intensity**, the **Intensity value (0 to 1)** parameter appears on the dialog box.

### Intensity value

Enter a scalar intensity value from 0 to 1, where 0 corresponds to black and 1 corresponds to white. This parameter is visible if, for the **Display intensity** parameter, you select **User-specified intensity**. Tunable.

## Draw Shape (Obsolete)

---

### **ROI source**

Specify how you want to enter your ROI coordinates. If you select Specify via dialog, the **ROI [row column height width]** parameter appears on the dialog. If you select Input port, the ROI port appears on the dialog. The input to this port must be a four-element vector of integers. The first two elements represent the zero-based row and column coordinates of the upper left corner of the ROI. The second two elements represent the height and width of the ROI.

### **ROI [row column height width]**

Enter a four-element vector of integers. The first two elements represent the zero-based row and column coordinates of the upper left corner of the ROI. The second two elements represent the height and width of the ROI. Tunable.

**Purpose** Draw rectangles, lines, polygons, or circles on images

**Library** Text & Graphics

**Description** The Draw Shapes block can draw multiple rectangles, lines, polygons, or circles on images by overwriting pixel values. As a result, the shapes are embedded on the output image.

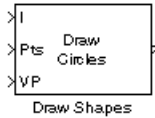

Port	Input/Output	Supported Data Types	Supports Complex Values?
I	Scalar, vector, or matrix of intensity values	<ul style="list-style-type: none"> <li>• Double-precision floating point</li> <li>• Single-precision floating point</li> <li>• Fixed point</li> <li>• Boolean</li> <li>• 8-, 16-, and 32-bit signed integers</li> <li>• 8-, 16-, and 32-bit unsigned integers</li> </ul>	No
R, G, B	Scalar, vector, or matrix that represents one plane of the input RGB video stream. Inputs to the R, G, and B ports must have the same dimensions and data type.	Same as I port	No

# Draw Shapes

Port	Input/Output	Supported Data Types	Supports Complex Values?
Pts	Use integer values to define zero-based shape coordinates. If you enter noninteger values, the block rounds them to the nearest integer.	<ul style="list-style-type: none"> <li>• Double-precision floating point</li> <li>• Single-precision floating point</li> <li>• 8-, 16-, and 32-bit signed integers</li> <li>• 8-, 16-, and 32-bit unsigned integers</li> </ul>	No
VP	Four-element vector of integers that defines a rectangular area in which you want to draw the shapes. The first two elements represent the zero-based row and column coordinates of the upper left corner of the area. The second two elements represent the height and width of the area.	<ul style="list-style-type: none"> <li>• Double-precision floating point</li> <li>• Single-precision floating point</li> <li>• 8-, 16-, and 32-bit signed integers</li> <li>• 8-, 16-, and 32-bit unsigned integers</li> </ul>	No
Output	Scalar, vector, or matrix of pixel values that contain the shape(s)	Same as I port	No

The output signal is the same size and data type as the inputs to the I, R, G, and B ports.

Use the **Input image type** parameter to specify the type of image input to the block. Your choices are Intensity or RGB.

Use the **Shape** parameter to specify the type of shape(s) to draw. Your choices are Rectangles, Lines, Polygons, or Circles.

Use the **Draw shapes in** parameter to define the area in which to draw the shapes. If you select Entire image, you can draw shapes in the entire image. If you select Specify region of interest via port,

the VP port appears on the block. Enter a four-element vector of integer values, [r c height width], where r and c are the row and column coordinates of the upper left corner of the area, and height and width represent the height (in rows) and width (in columns) of the area. If you specify values that are outside the image, the block sets the values to the image boundaries.

## Intensity Images

If, for the **Input image type** parameter you choose Intensity, the **Border intensity** parameter appears on the block. Use this parameter to determine the appearance of the rectangle(s), line(s), polygon(s), or circle(s). If you select Black, the border is black. If you select White, the border is white. If you select User-specified value, the **Intensity value** parameter appears on the dialog box. Enter a scalar intensity value between the minimum and maximum values that can be represented by the data type of the input image. The minimum value corresponds to black and the maximum value corresponds to white. If you enter a value outside this range, the block produces an error. You can specify a separate intensity value for each shape's border by entering a vector of intensities that is the same length as the total number of shapes.

If you select the **Filled** check box, the **Fill value intensity** and **Opacity factor (between 0 and 1)**, parameters appear on the dialog box. Use the **Fill value intensity** parameter to specify the intensity of the shading inside the shape. The word length of this value must be less than or equal to 32-bits. Use the **Opacity factor (between 0 and 1)** parameter to specify the opacity of the shading inside the shape, where 0 is transparent and 1 is opaque.

---

**Note** If you are generating code and you select the **Filled** check box, the word length of the block input(s) must be less than or equal to 16-bits.

---

# Draw Shapes

---

## Color Images

If, for the **Input image type** parameter you choose RGB, the **Border color** parameter appears on the block. Use this parameter to determine the appearance of the rectangle(s), line(s), polygon(s), or circle(s). If you select Black, the shape is black. If you select White, the shape is white. If you select User-specified value, the **RGB values** parameter appears on the dialog box. Enter a three-element vector of values between the minimum and maximum values that can be represented by the data type of the input image. The minimum value corresponds to an absence of color and the maximum value corresponds to the saturation of color. If you enter a value outside the data type range, the block produces an error. You can specify a separate RGB triplet for each shape by entering a 3-by-N matrix, where N is the total number of shapes.

If you select the **Filled** check box, the **Fill value color** and **Opacity factor (between 0 and 1)** parameters appear on the dialog box. Use the **Fill value color** parameter to specify the color of the shading inside the shape. For simulation, the word length of these values must be less than or equal to 32-bits. Use the **Opacity factor (between 0 and 1)** parameter to specify the opacity of the shading inside the shape, where 0 is transparent and 1 is opaque.

---

**Note** If you are generating code and you select the **Filled** check box, the word length of the block input(s) must be less than or equal to 16-bits.

---

## Drawing Rectangles

If you want to draw one rectangle, for the **Shape** parameter, choose Rectangles. The input to the Pts port must be a four-element vector of the form `[r c height width]`, where r and c are the zero-based row and column coordinates of the upper left corner of the rectangle, and height and width represent the height, in rows, and width, in columns, of the rectangle. Here, height and width must be greater than zero.



If you want to draw N rectangles, for the **Shape** parameter, choose Rectangles. The input to the Pts port must be a four-by-N matrix where each column defines a rectangle as described in the previous paragraph. For example, to draw two rectangles enter

$$\begin{bmatrix} r_1 & r_2 \\ c_1 & c_2 \\ height_1 & height_2 \\ width_1 & width_2 \end{bmatrix}$$

at the Pts port.

## Drawing Lines and Polylines

If you want to draw one line, for the **Shape** parameter, choose Lines. The input to the Pts port must be a four-element vector of the form [r1 c1 r2 c2], where r1 and c1 are the row and column coordinates of the beginning of the line and r2 and c2 are the row and column coordinates of the end of the line.

If you want to draw one polyline, which is a series of connected line segments, for the **Shape** parameter, choose Lines. For a polyline with L-1 line segments, the input to the Pts port must be a vector of size 2L, [r1 c1 r2 c2 ... rL cL]. Here, r1 and c1 are the row and column coordinates of the beginning of the first polyline, r2 and c2 are the row and column coordinates of the end of the first polyline and the beginning of the second polyline, etc. The block produces an error if the number of rows is less than two or is not a multiple of two.

If you want to draw N polylines, for the **Shape** parameter, choose Lines. If the biggest polyline has L-1 line segments, the input to the Pts port must be a 2L-by-N matrix, where each column of the matrix corresponds to a different polyline, as described in the previous paragraph. If some polylines are shorter than others, repeat the ending coordinates to fill the polyline matrix. The block produces an error if the number of rows is less than two or is not a multiple of two.

# Draw Shapes

---

## Drawing Polygons

If you want to draw one polygon, for the **Shape** parameter, choose **Polygons**. For a polygon with  $L$  line segments, the input to the **Pts** port must be a vector of size  $2L$ ,  $[r1\ c1\ r2\ c2\ \dots\ rL\ cL]$ . Here,  $r1$  and  $c1$  are the row and column coordinates of the beginning of the first line segment,  $r2$  and  $c2$  are the row and column coordinates of the end of the first line segment and the beginning of the second line segment, etc. The block connects  $[r1\ c1]$  to  $[rL\ cL]$  to complete the polygon. The block produces an error if the number of rows is negative or not a multiple of two.

If you want to draw  $N$  polygons, for the **Shape** parameter, choose **Polygons**. If the biggest polygon has  $L$  line segments, the input to the **Pts** port must be a  $2L$ -by- $N$  matrix, where each column of the matrix corresponds to a different polygon, as described in the previous paragraph. If some polygons have fewer line segments, repeat the ending coordinates until you fill the polygon matrix. The block produces an error if the number of rows is negative or not a multiple of two.

## Drawing Circles

If you want to draw one circle, for the **Shape** parameter, choose **Circles**. The input to the **Pts** port must be a three-element vector of the form  $[r\ c\ radius]$ , where  $r$  and  $c$  are the row and column coordinates of the center of the circle. The radius is the radius of the circle, which must be greater than zero.

If you want to draw  $N$  circles, for the **Shape** parameter, choose **Circles**. The input to the **Pts** port must be a three-by- $N$  matrix where each column defines a circle as described in the previous paragraph.

## Dialog Box

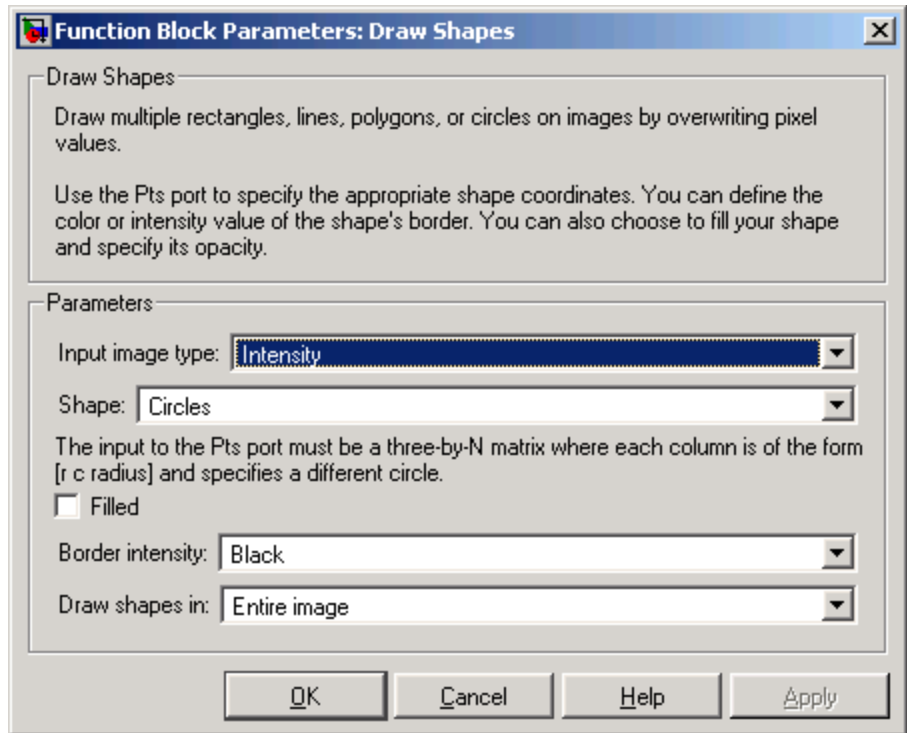

### Input image type

Specify the type of image input to the block. Your choices are Intensity or RGB.

### Shape

Specify the type of shape(s) to draw. Your choices are Rectangles, Lines, Polygons, or Circles.

### Filled

Select this check box to fill the shape with an intensity value or a color.

## **Border intensity**

Specify the appearance of the shape's border. If you select **Black**, the border is black. If you select **White**, the border is white. If you select **User-specified value**, the **Intensity value** parameter appears on the dialog box. This parameter is visible if, for the **Input image type** parameter, you select **Intensity**.

## **Intensity value**

Enter a scalar intensity value for the border or shading of the shape. This value must be between the minimum and maximum values that can be represented by the data type of the input image. The minimum value corresponds to black and the maximum value corresponds to white. This parameter is visible if, for the **Input image type** parameter, you select **Intensity** and, for the **Border intensity** parameter, you select **User-specified value**. Tunable.

## **Opacity factor (between 0 and 1)**

Specify the opacity of the shading inside the shape, where 0 is transparent and 1 is opaque. This parameter is visible if you select the **Filled** check box.

## **Border color**

Specify the appearance of the shape's border. If you select **Black**, the border is black. If you select **White**, the border is white. If you select **User-specified value**, the **RGB values** parameter appears on the dialog box. This parameter is visible if, for the **Input image type** parameter, you select **RGB**.

## **RGB values**

Enter a three-element vector of values between the minimum and maximum values that can be represented by the data type of the input image. The minimum value corresponds to an absence of color and the maximum value corresponds to the saturation of color. This parameter is visible if, for the **Input image type** parameter, you select **RGB** and, for the **Border color** parameter, you select **User-specified value**. Tunable.

## Draw shapes in

Define the area in which to draw the shapes. If you select Entire image, you can draw shapes in the entire image. If you select Specify region of interest via port, the VP port appears on the block. Enter a four-element vector, [r c height width], where r and c are the row and column coordinates of the upper left corner of the area, and height and width represent the height (in rows) and width (in columns) of the area.

## See Also

Draw Markers

Video and Image Processing  
Blockset

Insert Text

Video and Image Processing  
Blockset

# Edge Detection

**Purpose** Find edges of objects in images using the Sobel, Prewitt, or Roberts method

**Library** Analysis & Enhancement

**Description** The Edge Detection block finds the edges in an input image by approximating the gradient magnitude of the image. The block convolves the input matrix with the Sobel, Prewitt, or Roberts kernel. The block outputs two gradient components of the image, which are the result of this convolution operation. Alternatively, the block can perform a thresholding operation on the gradient magnitudes and output a binary image, which is a matrix of Boolean values. If a pixel value is 1, it is an edge.

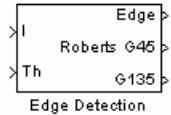

Port	Input/Output	Supported Data Types	Supports Complex Values?
I	Matrix of intensity values	<ul style="list-style-type: none"> <li>• Double-precision floating point</li> <li>• Single-precision floating point</li> <li>• Fixed point</li> <li>• 8-, 16-, 32-bit unsigned integers</li> </ul>	No
Th	Matrix of intensity values	Same as I port	No
Edge	Matrix that represents a binary image	<ul style="list-style-type: none"> <li>• Boolean</li> </ul>	No

Port	Input/Output	Supported Data Types	Supports Complex Values?
Gv	Matrix of gradient values in the vertical direction	Same as I port	No
Gh	Matrix of gradient values in the horizontal direction	Same as I port	No
G45	Matrix of gradient values	Same as I port	No
G135	Matrix of gradient values	Same as I port	No

The output of the Gv, Gh, G45, and G135 ports is the same data type as the input to the I port. The input to the Th port must be the same data type as the input to the I port.

Use the **Method** parameter to specify which algorithm to use to calculate the approximation of the gradient of the input image. You can select Sobel, Prewitt, or Roberts to find edges using the Sobel, Prewitt, or Roberts method.

Use the **Output type** parameter to select the format of the output. If you select Binary image, the block outputs a Boolean matrix at the Edge port. The nonzero elements of this matrix correspond to the edge pixels and the zero elements correspond to the background pixels. If you select Gradient components and, for the **Method** parameter, you select Sobel or Prewitt, the block outputs the gradient components that correspond to the horizontal and vertical edge responses at the Gh and Gv ports, respectively. If you select Gradient components and, for the **Method** parameter, you select Roberts, the block outputs the gradient components that correspond to the 45 and 135 degree edge responses at the G45 and G135 ports, respectively. If you select Binary image and gradient components, the block outputs both the binary image and the gradient components of the image.

# Edge Detection

---

Select the **User-defined threshold** check box to define a threshold value. If you clear this check box, the block computes the threshold for you.

Use the **Threshold source** parameter to specify how to enter your threshold value. If you select *Specify via dialog*, the **Threshold** parameter appears in the dialog box. Enter a threshold value that is within the range of your input data. If you choose *Input port*, use input port *Th* to specify a threshold value. This value must have the same data type as the input data. Gradient magnitudes above the threshold value correspond to edges.

The block computes the automatic threshold using the mean of the gradient magnitude squared image. However, you can adjust this threshold using the **Threshold scale factor** parameter. The block multiplies the value you enter with the automatic threshold value to determine a new threshold value.

Select the **Edge thinning** check box to reduce the thickness of the edges in your output image. This option requires additional processing time and memory resources.

---

**Note** This block is most efficient in terms of memory usage and processing time when you clear the **Edge thinning** check box and use the **Threshold** parameter to specify a threshold value.

---

## Fixed-Point Data Types

The following diagram shows the data types used within the Edge Detection block for fixed-point signals.



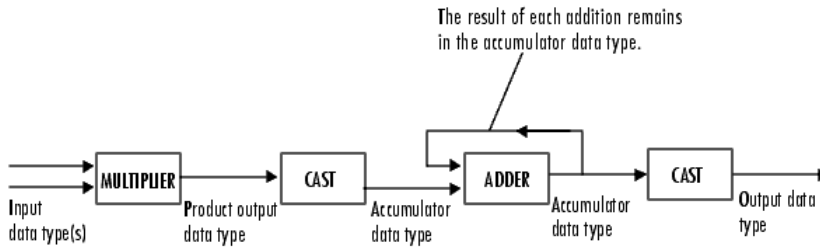

You can set the product output and accumulator data types in the block mask as discussed below.

## Dialog Box

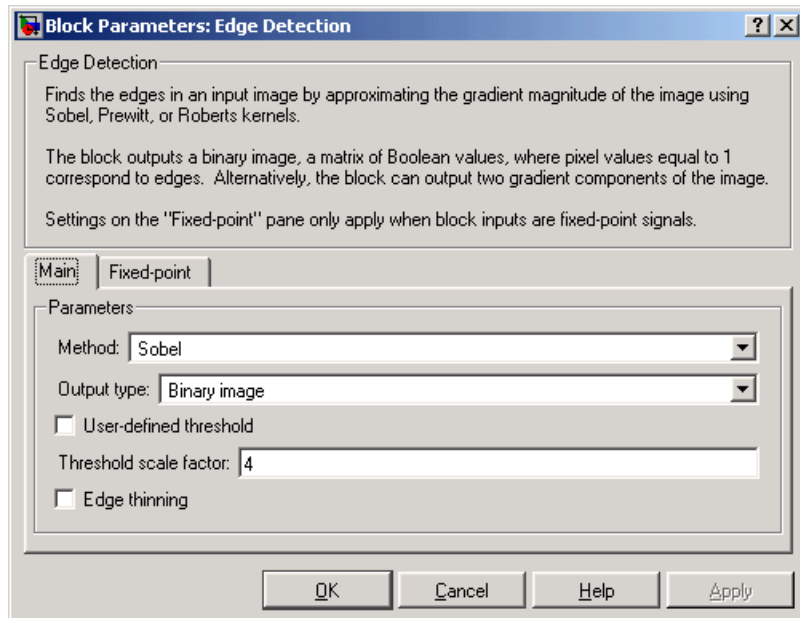

## Method

Select the method by which you want to perform edge detection. Your choices are Sobel, Prewitt, or Roberts.

## Output type

Select the desired form of the output. If you select Binary image, the block outputs a matrix that is filled with ones, which correspond to edges, and zeros, which correspond to the background. If you select Gradient components and, for the **Method** parameter, you select Sobel or Prewitt, the block outputs the gradient components that correspond to the horizontal and vertical edge responses. If you select Gradient components and, for the **Method** parameter, you select Roberts, the block outputs the gradient components that correspond to the 45 and 135 degree edge responses. If you select Binary image and gradient components, the block outputs both the binary image and the gradient components of the image.

## User-defined threshold

If you select this check box, you can enter a desired threshold value. If you clear this check box, the block computes the threshold for you. This parameter is visible if, for the **Output type** parameter, you select Binary image or Binary image and gradient components.

## Threshold source

If you select Specify via dialog, enter your threshold value in the dialog box. If you choose Input port, use the Th input port to specify a threshold value that is the same data type as the input data. This parameter is visible if you select the **User-defined threshold** check box.

## Threshold

Enter a threshold value that is within the range of your input data. This parameter is visible if, for **Threshold source** parameter, you select Specify via dialog. Tunable.

## Threshold scale factor

Enter a multiplier that is used to adjust the calculation of the automatic threshold. This parameter is visible if you clear the **User-defined threshold** check box. Tunable.

## Edge thinning

Select this check box if you want the block to perform edge thinning. This option requires additional processing time and memory resources. This parameter is visible if, for the **Output type** parameter, you select Binary image or Binary image and gradient components.

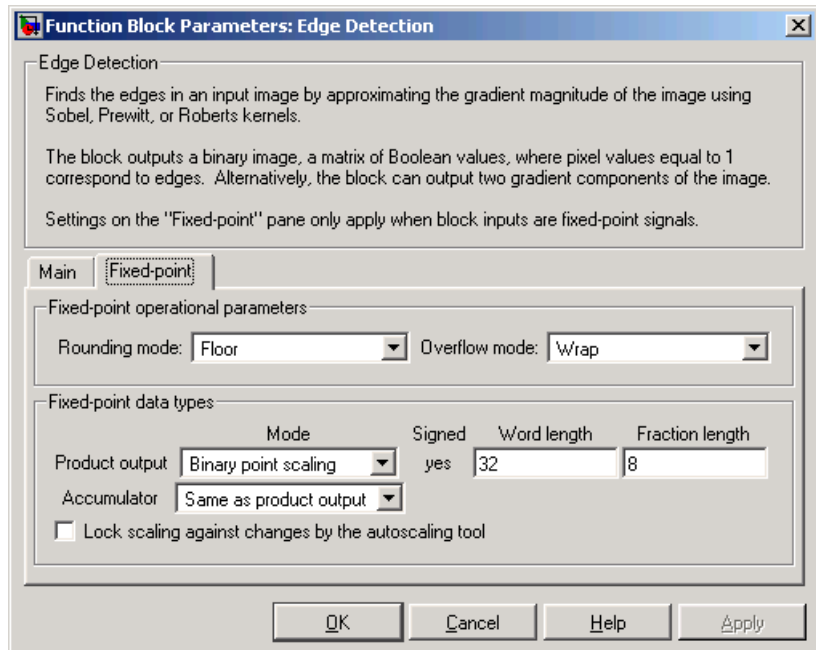

## Rounding mode

Select the rounding mode for fixed-point operations.

## Overflow mode

Select the overflow mode for fixed-point operations.

# Edge Detection

## Product output



Here, the internal coefficients are the Sobel, Prewitt, or Roberts masks. As depicted above, the output of the multiplier is placed into the product output data type and scaling. Use this parameter to specify how you would like to designate this product output word and fraction lengths.

- When you select Same as first input, these characteristics will match those of the first input to the block.
- When you select Binary point scaling, you can enter the word length and the fraction length of the product output, in bits.
- When you select Slope and bias scaling, you can enter the word length, in bits, and the slope of the product output. The bias of all signals in the Signal Processing Blockset is zero.

## Accumulator

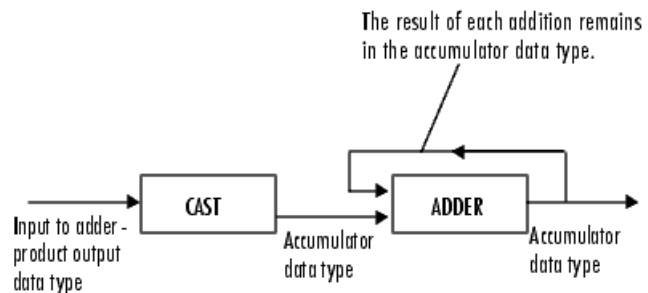

As depicted above, inputs to the accumulator are cast to the accumulator data type. The output of the adder remains in the accumulator data type as each element of the input is added to it. Use this parameter to specify how you would like to designate this accumulator word and fraction lengths.

- When you select `Same as product output`, these characteristics will match those of the product output.
- When you select `Same as first input`, these characteristics will match those of the first input to the block.
- When you select `Binary point scaling`, you can enter the word length and the fraction length of the accumulator, in bits.
- When you select `Slope and bias scaling`, you can enter the word length, in bits, and the slope of the accumulator. The bias of all signals in the Signal Processing Blockset is zero.

## Gradients

Choose how you will specify the word length and fraction length of the outputs of the Gv and Gh ports. This parameter is visible if, for the **Output type** parameter, you choose `Gradient components` or `Binary image and gradient components`:

- When you select `Same as accumulator`, these characteristics will match those of the accumulator.
- When you select `Same as product output`, these characteristics will match those of the product output.
- When you select `Same as first input`, these characteristics will match those of the first input to the block.
- When you select `Binary point scaling`, you can enter the word length and the fraction length of the output, in bits.
- When you select `Slope and bias scaling`, you can enter the word length, in bits, and the slope of the output. The bias of all signals in the Signal Processing Blockset is zero.

# Edge Detection

---

## **Lock scaling against changes by the autoscaling tool**

Select this parameter to prevent any fixed-point scaling you specify in this block mask from being overridden by the autoscaling tool in the Fixed-Point Settings interface. For more information about the autoscaling tool, refer to the Fixed-Point Settings Interface section of the Signal Processing Blockset User's Guide.

## **References**

[1] Gonzales, Rafael C. and Richard E. Woods. *Digital Image Processing. 2nd ed.* Englewood Cliffs, NJ: Prentice-Hall, 2002.

[2] Pratt, William K. *Digital Image Processing. 2nd ed.* New York: John Wiley & Sons, 1991.

## **See Also**

edge

Image Processing Toolbox

## Purpose

Find local minima in binary or intensity images

## Library

Morphological Operations

## Description

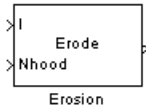

The Erosion block slides the neighborhood or structuring element over an image, finds the local minima, and creates the output matrix from these minimum values. If the neighborhood or structuring element has a center element, the block places the minima there, as illustrated below.

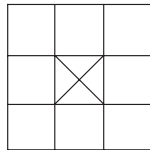

If the neighborhood or structuring element does not have an exact center, the block has a bias toward the upper left corner and places the minima there, as illustrated below.

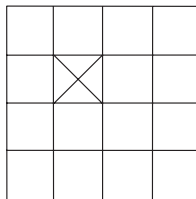

This block uses flat structuring elements only.

# Erosion

Port	Input/Output	Supported Data Types	Supports Complex Values?
I	Vector or matrix of intensity values	<ul style="list-style-type: none"><li>• Double-precision floating point</li><li>• Single-precision floating point</li><li>• Fixed point</li><li>• Boolean</li><li>• 8-, 16-, and 32-bit signed integers</li><li>• 8-, 16-, and 32-bit unsigned integers</li></ul>	No
Nhood	Matrix or vector of ones and zeros that represents the neighborhood values	<ul style="list-style-type: none"><li>• Boolean</li></ul>	No
Output	Vector or matrix of intensity values that represents the eroded image	Same as I port	No

The output signal is the same data type as the input to the I port. This block supports a signal represented by a Simulink virtual bus.

Use the **Neighborhood or structuring element source** parameter to specify how you want to enter your neighborhood or structuring element values. If you select `Specify via dialog`, the **Neighborhood or structuring element** parameter appears on the dialog box. If you select `Input port`, the Nhood port appears on the block. Use this port to enter your neighborhood values as a matrix or vector of ones and zeros. You can only specify a structuring element using the dialog box.

Use the **Neighborhood or structuring element** parameter to define the neighborhood or structuring element that the block applies to the image. Specify a neighborhood by entering a matrix or vector of ones and zeros. Specify a structuring element with the `strel` function from the Image Processing Toolbox. If the structuring element is decomposable into smaller elements, the block executes at higher speeds due to the



use of a more efficient algorithm. If you enter an array of STREL objects, the block applies each object to the entire matrix in turn.

## Dialog Box

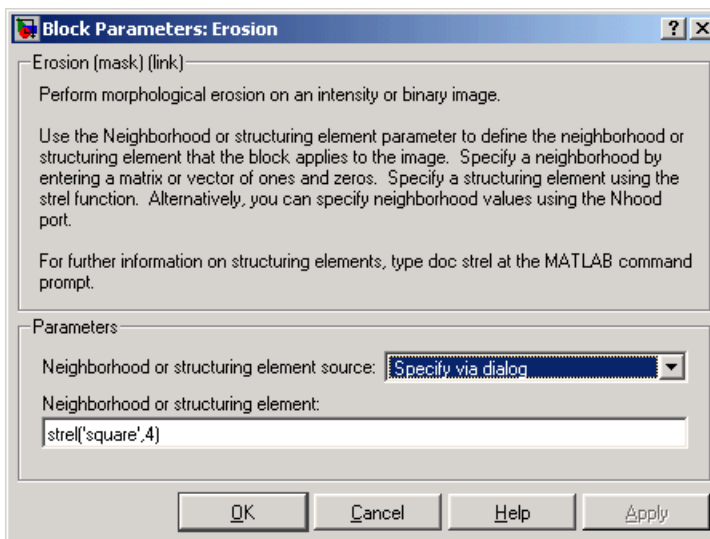

### Neighborhood or structuring element source

Specify how you want to enter your neighborhood or structuring element values. Select *Specify via dialog* to enter the values in the dialog box. Select *Input port* to use the Nhood port to specify the neighborhood values. You can only specify a structuring element using the dialog box.

### Neighborhood or structuring element

If you are specifying a neighborhood, this parameter must be a matrix or vector of ones and zeros. If you are specifying a structuring element, use the `strel` function from the Image Processing Toolbox. This parameter is visible if, for the **Neighborhood or structuring element source** parameter, you select *Specify via dialog*.

# Erosion

---

## References

Soille, Pierre. *Morphological Image Analysis. 2nd ed.* New York: Springer, 2003.

## See Also

Bottom-hat	Video and Image Processing Blockset
Closing	Video and Image Processing Blockset
Dilation	Video and Image Processing Blockset
Label	Video and Image Processing Blockset
Opening	Video and Image Processing Blockset
Top-hat	Video and Image Processing Blockset
imerode	Image Processing Toolbox
strel	Image Processing Toolbox

**Purpose** Find local maxima in matrices

**Library** Statistics

**Description**

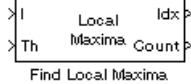

The Find Local Maxima block finds the local maxima in each input matrix. The block slides a neighborhood over the matrix and finds the maximum value within the neighborhood. If this maximum value is greater than or equal to a user-specified threshold, the block considers the value a valid local maximum. Then, it sets all the matrix values in the neighborhood to zero. The block repeats this process until either it finds all the valid maxima or it finds the number of local maxima equal to the **Maximum number of local maxima (N)** parameter, whichever comes first.

The block outputs the zero-based row and column coordinates of the maxima at the Idx port and the number of valid local maxima found at the Count port.

Port	Input/Output	Supported Data Types	Supports Complex Values?
I/ Hough	Matrix in which you want to find the maxima	<ul style="list-style-type: none"><li>• Double-precision floating point</li><li>• Single-precision floating point</li><li>• Fixed point (unsigned, fraction length must be zero)</li></ul>	No
Th	Scalar that represents the value the maxima should meet or exceed	Same as I/Hough port	No

# Find Local Maxima

Port	Input/Output	Supported Data Types	Supports Complex Values?
Idx	Vector or matrix that represents the zero-based coordinates of the maxima. The first column represents the row coordinates and the second column represents the column coordinates.	<ul style="list-style-type: none"><li>• Double-precision floating point</li><li>• Single-precision floating point</li><li>• 8-, 16-, and 32-bit unsigned integers</li></ul>	No
Count	Scalar that represents the number of maxima that meet or exceed the threshold value	Same as Idx port	No

The inputs to the I/Hough and Th ports must be the same data type.

Use the **Maximum number of local maxima (N)** parameter to specify the maximum number of maxima to find.

Use the **Neighborhood size** parameter to specify the size of the neighborhood around the maxima over which the block zeros out the values. Enter a two-element vector of positive odd integers, [r c]. Here, r is the number of rows in the neighborhood and c is the number of columns.

Use the **Source of threshold value** parameter to specify how you want to enter the threshold value. If you select Input port, the Th port appears on the block. If you select Specify via dialog, the **Threshold** parameter appears on the dialog box. Enter a scalar that represents the value all maxima should meet or exceed.

If the input to this block is a Hough matrix output from the Hough Transform block, select the **Input is Hough matrix spanning full theta range** check box. If you select this check box, the block assumes that the Hough port input is antisymmetric about the rho axis and

theta ranges from  $-\pi/2$  to  $\pi/2$  radians. If the block finds a local maxima near the boundary such that the neighborhood lies outside the Hough matrix, the block finds only one local maximum, and it ignores the corresponding antisymmetric maximum.

Use the **Index output data type** parameter to specify the data type of the Idx port output. Your choices are double, single, unit8, uint16, or unit32.

Use the **Count output data type** parameter to specify the data type of the Count port output. Your choices are double, single, unit8, uint16, or unit32.

# Find Local Maxima

## Dialog Box

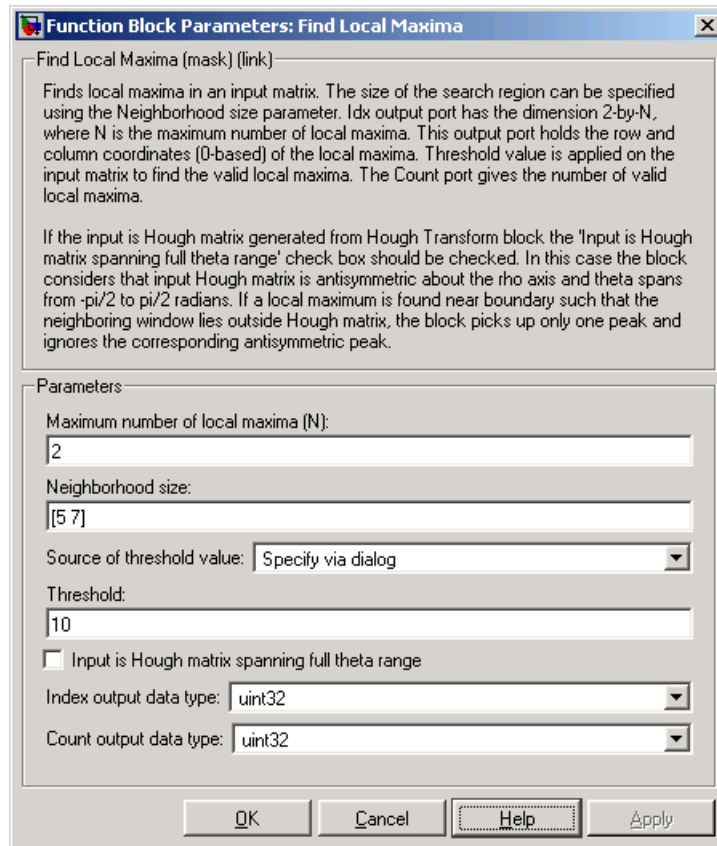

### Maximum number of local maxima (N)

Specify the maximum number of maxima you want the block to find.

### Neighborhood size

Specify the size of the neighborhood around the maxima over which the block zeros out the values. Enter a two-element vector of positive odd integers, [r c].

## Source of threshold value

Specify how you want to enter the threshold value. If you select Input port, the Th port appears on the block. If you select Specify via dialog, the **Threshold** parameter appears on the dialog box.

## Threshold

Enter a scalar that represents the value all maxima should meet or exceed. This parameter is visible if, for the **Source of threshold value** parameter, you choose Specify via dialog.

## Input is Hough matrix spanning full theta range

If you select this check box, the block assumes that the Hough port input is antisymmetric about the rho axis and theta ranges from  $-\pi/2$  to  $\pi/2$  radians.

## Index output data type

Specify the data type of the Peaks port output. Your choices are double, single, uint8, uint16, or uint32.

## Count output data types

Specify the data type of the Count port output. Your choices are double, single, uint8, uint16, or uint32.

## See Also

Hough Lines	Video and Image Processing Blockset
Hough Transform	Video and Image Processing Blockset

# Frame Rate Display

**Purpose** Calculate and display frame rate of signals

**Library** Sinks

**Description** The Frame Rate Display block calculates and displays the frame rate of the input signal in frames per second (fps).

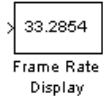

Port	Input	Supported Data Types	Supports Complex Values?
Input	Signal whose frame rate you want to monitor	<ul style="list-style-type: none"><li>• Double-precision floating point</li><li>• Single-precision floating point</li><li>• Fixed point</li><li>• Boolean</li><li>• 8-, 16-, and 32-bit signed integers</li><li>• 8-, 16-, and 32-bit unsigned integers</li></ul>	No

Use the **Calculate and display rate every** parameter to control how often the block updates the display. When this parameter is greater than 1, the block displays the average frame rate for the specified number of frames. For example, if you enter 10, the block calculates the amount of time it takes for the model to pass 10 frames to the block. It divides this time by 10 and displays this average frame rate on the block.



## Dialog Box

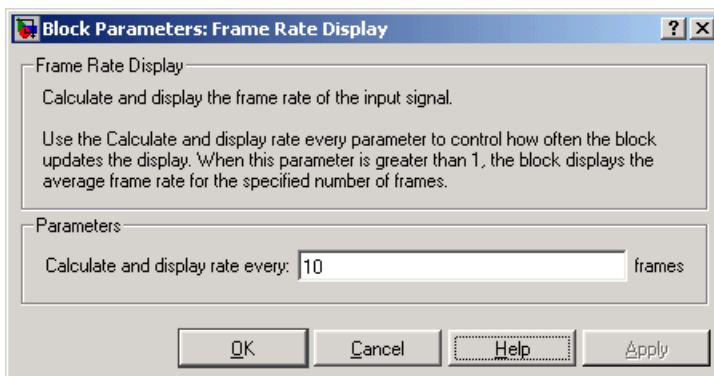

### Calculate and display rate every

Use this parameter to control how often the block updates the display.

## See Also

To Multimedia File	Video and Image Processing Blockset
To Video Display	Video and Image Processing Blockset
Video To Workspace	Video and Image Processing Blockset
Video Viewer	Video and Image Processing Blockset

# From Multimedia File

---

**Purpose** Read video frames and/or audio samples from compressed multimedia file

**Library** Sources

**Description** The From Multimedia File block is a Signal Processing Blockset block. For more information, see the From Multimedia File block reference page in the Signal Processing Blockset documentation.

## Purpose

Apply or remove gamma correction from images or video streams

## Library

Conversions

## Description

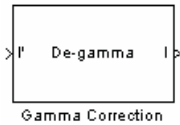
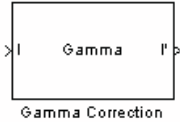

Use the Gamma Correction block to apply or remove gamma correction from an image or video stream. For input signals normalized between 0 and 1, the block performs gamma correction as defined by the following equations. Note that for integers and fixed-point data types, these equations are generalized by applying scaling and offset values specific to the data type:

$$S_{LS} = \frac{1}{\frac{\gamma}{B_P^{(\frac{1}{\gamma}-1)}} - \gamma B_P + B_P}$$

$$F_S = \frac{\gamma S_{LS}}{B_P^{(\frac{1}{\gamma}-1)}}$$

$$C_O = F_S B_P^{\frac{1}{\gamma}} - S_{LS} B_P$$

$$I' = \left\{ \begin{array}{ll} S_{LS} I, & I \leq B_P \\ F_S I^{\frac{1}{\gamma}} - C_O, & I > B_P \end{array} \right\}$$

$S_{LS}$  is the slope of the straight line segment.  $B_P$  is the break point of the straight line segment, which corresponds to the **Break point** parameter.  $F_S$  is the slope matching factor, which matches the slope of the linear segment to the slope of the power function segment.  $C_O$  is the segment offset, which ensures that the linear segment and the power function segments connect. Some of these parameters are illustrated by the following diagram.

# Gamma Correction

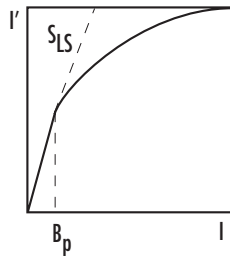

For normalized input signals, the block removes gamma correction, which linearizes the input video stream, as defined by the following equation:

$$I = \begin{cases} I' / S_{LS}, & I' \leq B_P \\ \left( \frac{I' + C_O}{F_S} \right)^\gamma, & I' > B_P \end{cases}$$

Typical gamma values range from 1 to 3. Most monitor gamma values range from 1.8 to 2.2. Check with the manufacturer of your hardware to obtain the exact gamma value. Gamma function parameters for some common standards are shown in the following table:

Standard	Slope	Break Point	Gamma
CIE L*	9.033	0.008856	3
Recommendation ITU-R BT.709-3, Parameter Values for the HDTV Standards for Production and International Programme Exchange	4.5	0.018	20/9
sRGB	12.92	0.0031308	2.4

The properties of the input and output ports are summarized in the following table:

Port	Input/Output	Supported Data Types	Supports Complex Values?
I	Scalar, vector, or matrix of intensity values or scalar, vector, or matrix that represents one plane of the RGB video stream	<ul style="list-style-type: none"> <li>• Double-precision floating point</li> <li>• Single-precision floating point</li> <li>• Fixed point (up to 16-bit word length)</li> <li>• 8- and 16-bit signed integers</li> <li>• 8- and 16-bit unsigned integers</li> </ul>	No
I'	Scalar, vector, or matrix of intensity values or scalar, vector, or matrix that represents one plane of the RGB video stream	Same as I port	No

Use the **Operation** parameter to specify the block's operation. If you want to perform gamma correction, select Gamma. If you want to linearize the input signal, select De-gamma.

If, for the **Operation** parameter, you select Gamma, use the **Gamma** parameter to enter the desired gamma value of the output video stream. This value must be greater than or equal to 1. If, for the **Operation** parameter, you select De-gamma, use the **Gamma** parameter to enter the gamma value of the input video stream.

Select the **Linear segment** check box if you want the gamma curve to have a linear portion near black. If you select this check box, the **Break point** parameter appears on the dialog. Enter a scalar that indicates the *I*-axis value of the end of the linear segment. The break point is shown in the first diagram of this block reference page.

# Gamma Correction

## Dialog Box

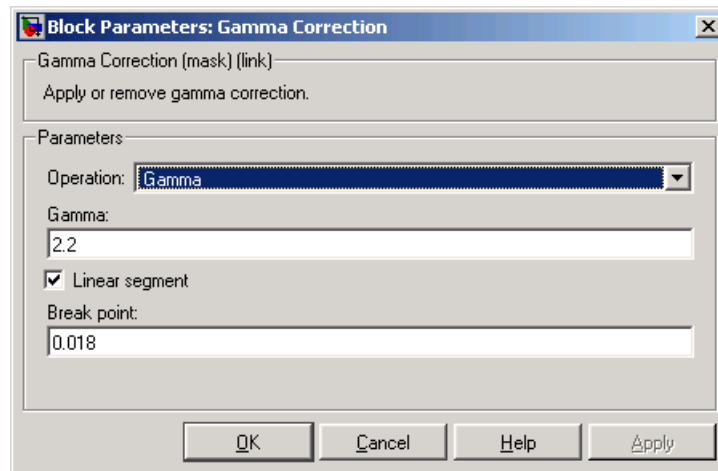

### Operation

Specify the block's operation. Your choices are Gamma or De-gamma.

### Gamma

If, for the **Operation** parameter, you select Gamma, enter the desired gamma value of the output video stream. This value must be greater than or equal to 1. If, for the **Operation** parameter, you select De-gamma, enter the gamma value of the input video stream. Tunable.

### Linear segment

Select this check box if you want the gamma curve to have a linear portion near the origin. Tunable.

### Break point

Enter a scalar that indicates the *I*-axis value of the end of the linear segment. This parameter is visible if you select the **Linear segment** check box. Tunable.

## Reference

Poynton, Charles. *Digital Video and HDTV Algorithms and Interfaces*. San Francisco, CA: Morgan Kaufman Publishers, 2003.

### See Also

Color Space Conversion

`imadjust`

Video and Image Processing Blockset

Image Processing Toolbox

# Histogram Equalization

**Purpose** Enhance contrast of images using histogram equalization

**Library** Analysis & Enhancement

**Description** The Histogram Equalization block enhances the contrast of images by transforming the values in an intensity image so that the histogram of the output image approximately matches a specified histogram.

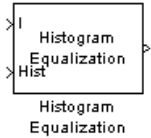

Port	Input/Output	Supported Data Types	Supports Complex Values?
I	Matrix of intensity values	<ul style="list-style-type: none"><li>• Double-precision floating point</li><li>• Single-precision floating point</li><li>• Fixed point</li></ul>	No
Hist	Vector of integer values that represents the desired intensity values in each bin	<ul style="list-style-type: none"><li>• Double-precision floating point</li><li>• Single-precision floating point</li><li>• 8-, 16-, 32-bit signed integers</li><li>• 8-, 16-, 32-bit unsigned integers</li></ul>	No
Output	Matrix of intensity values	Same as I port	No

If the data type of input to the I port is floating point, the input to Hist port must be the same data type. The output signal has the same data type as the input signal. This block supports a signal represented by a Simulink virtual bus.

Use the **Target histogram** parameter to designate the histogram you want the output image to have.

If you select **Uniform**, the block transforms the input image so that the histogram of the output image is approximately flat. Use the **Number**



**of bins** parameter to enter the number of equally spaced bins you want the uniform histogram to have.

If you select User-defined, the **Histogram source** and **Histogram** parameters appear on the dialog. Use the **Histogram source** parameter to select how you want to specify your histogram. If, for the **Histogram source** parameter, you select Specify via dialog, you can use the **Histogram** parameter to enter the desired histogram of the output image. The histogram should be a vector of integer values that represents the desired intensity values in each bin. The block transforms the input image so that the histogram of the output image is approximately the specified histogram.

If, for the **Histogram source** parameter, you select Input port, the Hist port appears on the block. Use this port to specify your desired histogram.

---

**Note** The vector input to the Hist port must be normalized such that the sum of the values in all the bins is equal to the number of pixels in the input image. The block does not error if the histogram is not normalized.

---

## Dialog Box

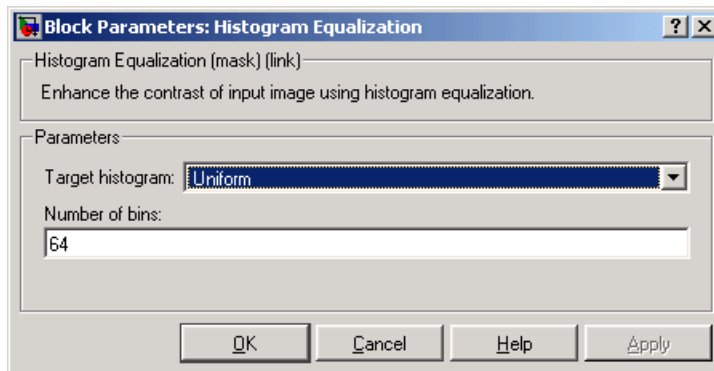

# Histogram Equalization

---

## **Target histogram**

Designate the histogram you want the output image to have. If you select `Uniform`, the block transforms the input image so that the histogram of the output image is approximately flat. If you select `User-defined`, you can specify the histogram of your output image.

## **Number of bins**

Enter the number of equally spaced bins you want the uniform histogram to have. This parameter is visible if, for the **Target histogram** parameter, you select `Uniform`.

## **Histogram source**

Select how you want to specify your histogram. Your choices are `Specify via dialog` and `Input port`. This parameter is visible if, for the **Target histogram** parameter, you select `User-defined`.

## **Histogram**

Enter the desired histogram of the output image. This parameter is visible if, for the **Target histogram** parameter, you select `User-defined`. Tunable.

## **See Also**

<code>imadjust</code>	Image Processing Toolbox
<code>histeq</code>	Image Processing Toolbox

## Purpose

Find Cartesian coordinates of lines that are described by rho and theta pairs

## Library

Transforms

## Description

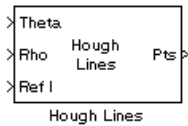

The Hough Lines block inputs are the theta and rho values of lines and a reference image. The block outputs the zero-based row and column positions of the intersections between the lines and two of the reference image boundary lines. The boundary lines are the left and right vertical boundaries and the top and bottom horizontal boundaries of the reference image.

Suppose that Line1 and Line2 intersect the boundaries of the reference image as shown below.

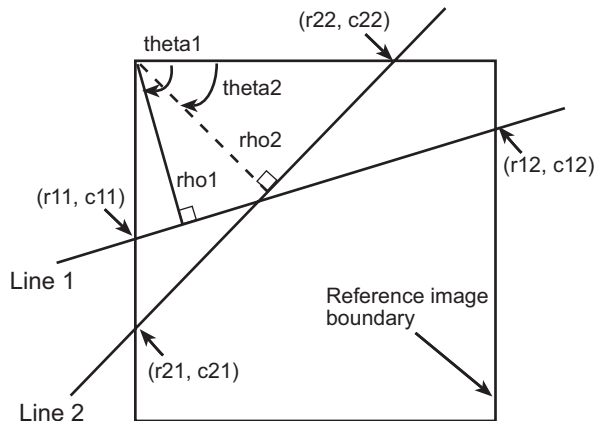

When the reference image and the theta and rho values of these lines are passed into the Hough Lines block, it outputs the coordinates of the intersections, as shown in the following figure.

$$\begin{bmatrix} theta1 \\ theta2 \end{bmatrix} \text{ or } [theta1 \quad theta2]$$

# Hough Lines

Port	Input/Output	Supported Data Types	Supports Complex Values?
Theta	Vector of theta values that represent input line(s)	<ul style="list-style-type: none"><li>• Double-precision floating point</li><li>• Single-precision floating point</li><li>• Fixed point (signed)</li></ul>	No
Rho	Vector of rho values that represent input line(s)	Same as Theta port	No
Ref I	Matrix that represents a binary or intensity image or matrix that represents one plane of an RGB image	<ul style="list-style-type: none"><li>• Double-precision floating point</li><li>• Single-precision floating point</li><li>• Fixed point (signed and unsigned)</li><li>• Custom data types</li><li>• Boolean</li><li>• 8-, 16-, and 32-bit signed integers</li><li>• 8-, 16-, and 32-bit unsigned integers</li></ul>	No
Pts	4-by-N matrix of intersection values, where N is the number of input lines	<ul style="list-style-type: none"><li>• 32-bit signed integers</li></ul>	No

Use the **Sine value computation method** parameter to specify how much memory the Hough Lines block requires. If you select `Trigonometric function`, the block computes sine and cosine values it needs to calculate the intersections of the lines during the simulation. If you select `Table lookup`, the block computes and stores the trigonometric values it needs to calculate the intersections of the lines before the simulation starts. In this case, the block requires extra memory.

---

**Note** For floating-point inputs, the **Sine value computation method** parameter must be set to `Trigonometric function`. For fixed-point inputs, the parameter must be set to `Table lookup`.

---

If, for the **Sine value computation method** parameter, you select `Table lookup`, the **Theta resolution (radians)** parameter appears on the dialog box. Use this parameter to specify the spacing of the theta-axis.

### **Fixed-Point Data Types**

The following diagram shows the data types used within the Hough Lines block for fixed-point signals.

# Hough Lines

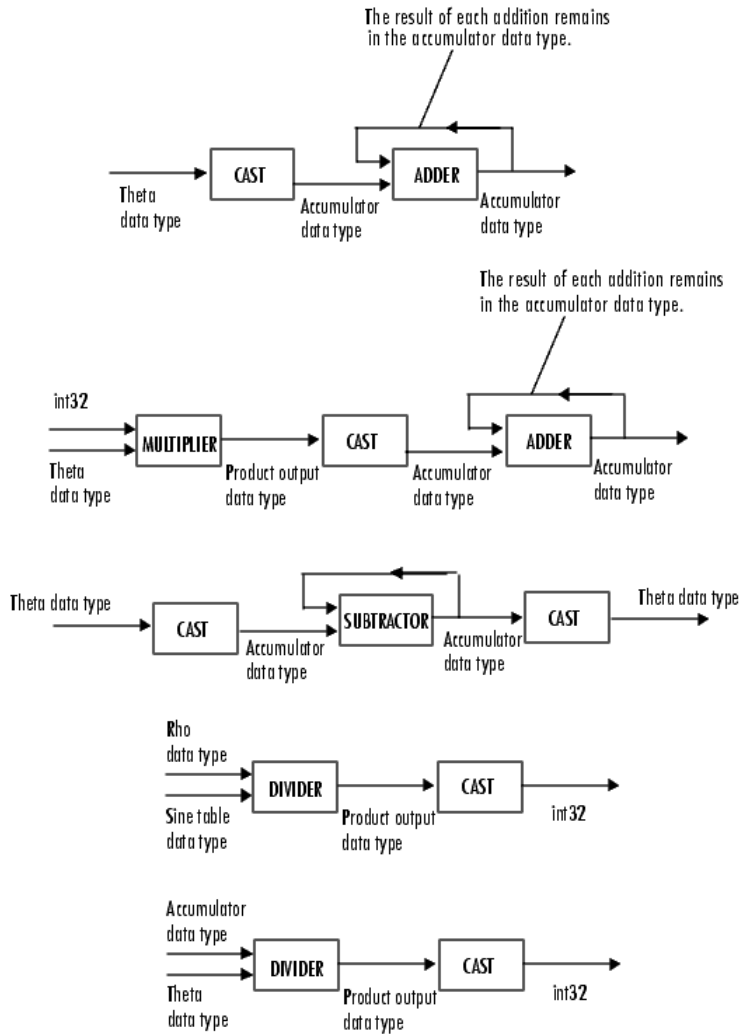

You can set the sine table, product output, and accumulator output data types in the block mask as discussed below.

## Dialog Box

The **Main** pane of the Hough Lines block dialog appears as follows:

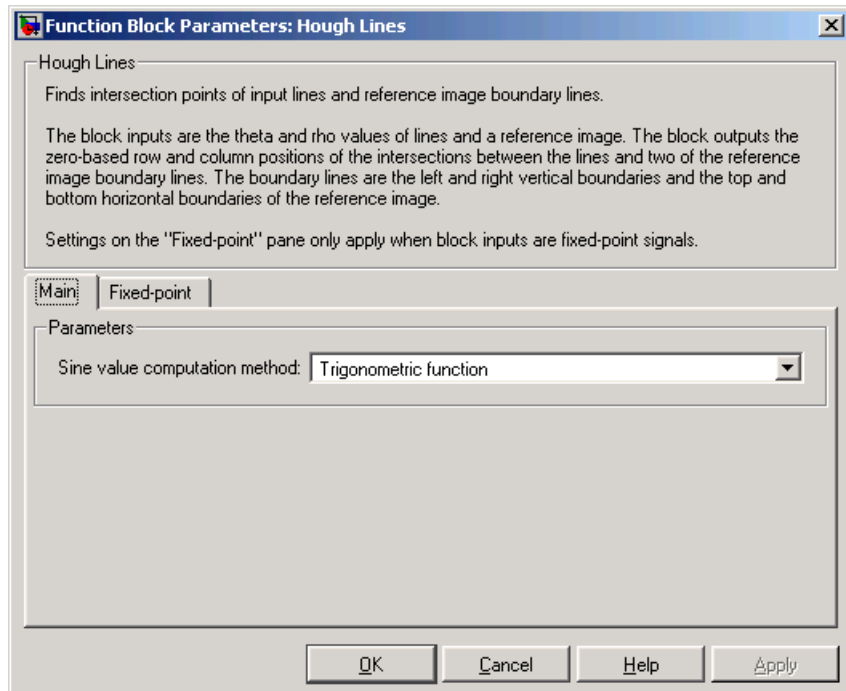

### Sine value computation method

If you select `Trigonometric function`, the block computes sine and cosine values it needs to calculate the intersections of the lines during the simulation. If you select `Table lookup`, the block computes and stores the trigonometric values it needs to calculate the intersections of the lines before the simulation starts. In this case, the block requires extra memory. For floating-point inputs, this parameter must be set to `Trigonometric function`. For fixed-point inputs, the parameter must be set to `Table lookup`.

# Hough Lines

## Theta resolution (radians)

Specify the spacing of the theta-axis. This parameter is visible if, for the **Sine value computation method** parameter, you choose Table lookup.

The **Fixed-point** pane of the Hough Lines block dialog appears as follows:

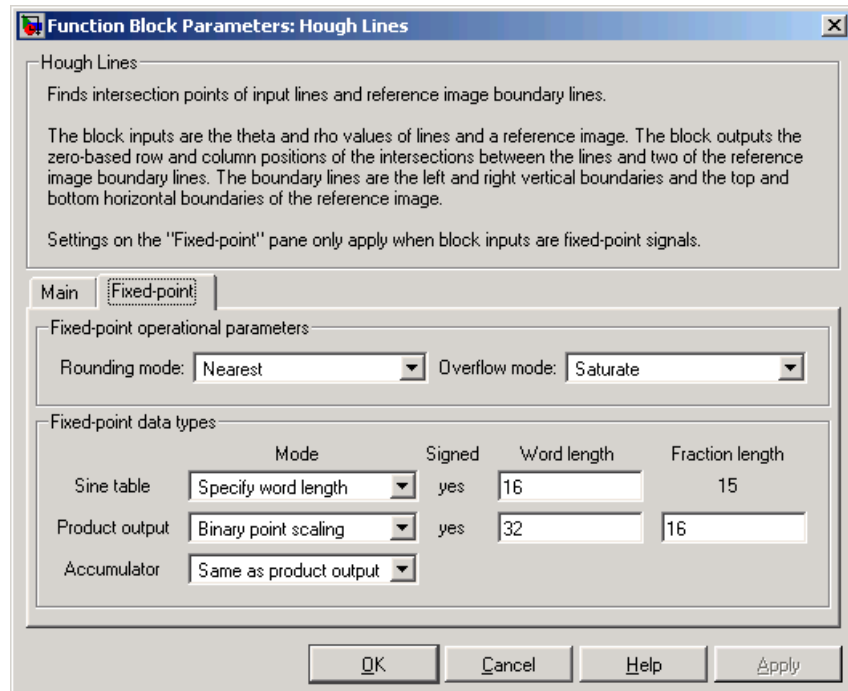

## Rounding mode

Select the rounding mode for fixed-point operations.

## Overflow mode

Select the overflow mode for fixed-point operations.



## Sine table

Choose how you will specify the word length of the values of the sine table. The fraction length of the sine table values is always equal to the word length minus one:

When you select `Specify word length`, you can enter the word length of the sine table.

When you select `Binary point scaling`, you can enter the word length of the sine table values, in bits.

When you select `Slope and bias scaling`, you can enter the word length of the sine table values, in bits.

The sine table values do not obey the **Rounding mode** and **Overflow mode** parameters; they are always saturated and rounded to Nearest.

## Product output



As depicted above, the output of the multiplier is placed into the product output data type and scaling. Use this parameter to specify how you would like to designate this product output word and fraction lengths:

When you select `Same as first input`, these characteristics will match those of the first input to the block.

When you select `Binary point scaling`, you can enter the word length and the fraction length of the product output, in bits.

# Hough Lines

---

When you select Slope and bias scaling, you can enter the word length, in bits, and the slope of the product output. The bias of all signals in the Video and Image Processing Blockset is zero.

## Accumulator

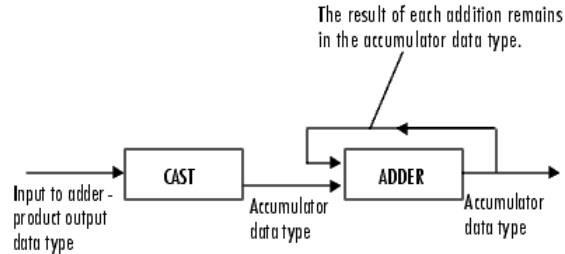

As depicted above, inputs to the accumulator are cast to the accumulator data type. The output of the adder remains in the accumulator data type as each element of the input is added to it. Use this parameter to specify how you would like to designate this accumulator word and fraction lengths.

- When you select Same as product output, these characteristics will match those of the product output.
- When you select Binary point scaling, you can enter the word length and the fraction length of the accumulator, in bits.
- When you select Slope and bias scaling, you can enter the word length, in bits, and the slope of the accumulator. The bias of all signals in the Video and Images Processing Blockset is zero.

## See Also

2-D DCT	Video and Image Processing Blockset
2-D FFT	Video and Image Processing Blockset
2-D IDCT	Video and Image Processing Blockset

2-D IFFT

Video and Image Processing Blockset

Find Local Maxima

Video and Image Processing Blockset

Hough Transform

Video and Image Processing Blockset

# Hough Transform

**Purpose** Find lines in images

**Library** Transforms

**Description** Use the Hough Transform block to find lines in an image. The block maps points in the Cartesian image space to curves in the Hough parameter space using the following equation:

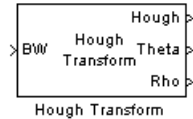

$$rho = x * \cos(theta) + y * \sin(theta)$$

The block outputs a parameter space matrix whose rows and columns correspond to the *rho* and *theta* values, respectively. Peak values in this matrix represent potential lines in the input image. The *theta* values range from  $-\pi/2$  radians to  $\pi/2$  radians with a step-size determined by the **Theta resolution (radians)** parameter.

Port	Input/Output	Supported Data Types	Supports Complex Values?
BW	Matrix that represents a binary image	<ul style="list-style-type: none"> <li>• Boolean</li> </ul>	No
Hough	Parameter space matrix	<ul style="list-style-type: none"> <li>• Double-precision floating point</li> <li>• Single-precision floating point</li> <li>• Fixed point</li> </ul>	No
Theta	Vector of theta values	Same as Hough port	No
Rho	Vector of rho values	Same as Hough port	No

If the output of the Hough port is floating point, the outputs of the Theta and Rho ports are the same data type.

Use the **Theta resolution (radians)** parameter to specify the spacing of the Hough transform bins along the *theta*-axis.

Use the **Rho resolution** parameter to specify the spacing of the Hough transform bins along the *rho*-axis.

If you select the **Output theta and rho values** check box, the Theta and Rho ports appear on the block. The block outputs vectors of theta and rho values at these ports.

Use the **Output data type** parameter to specify the data type of your output signal.

## Fixed-Point Data Types

The following diagram shows the data types used within the Hough Transform block for fixed-point signals.

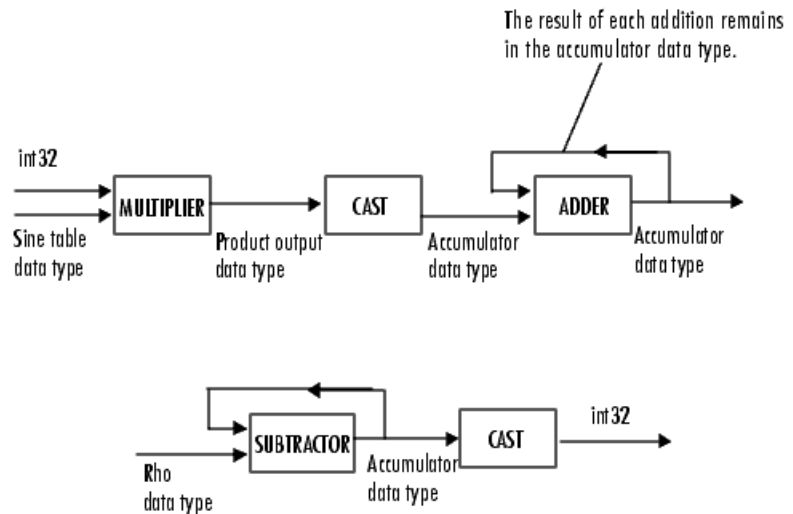

You can set the sine table, rho, product output, accumulator, Hough output, and Theta output data types in the block mask as discussed below.

# Hough Transform

## Dialog Box

The **Main** pane of the Hough Transform block dialog appears as follows:

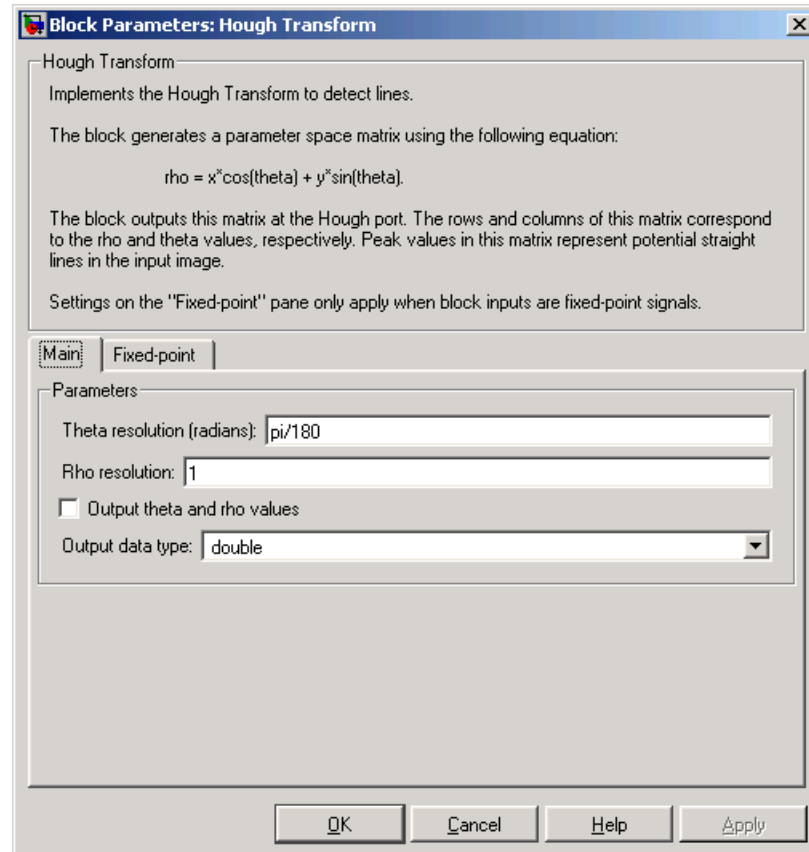

### Theta resolution (radians)

Specify the spacing of the Hough transform bins along the *theta*-axis.

### Rho resolution

Specify the spacing of the Hough transform bins along the *rho*-axis.

## **Output theta and rho values**

If you select this check box, the Theta and Rho ports appear on the block. The block outputs vectors of theta and rho values at these ports.

## **Output data type**

Specify the data type of your output signal.

The **Fixed-point** pane of the Hough Transform block dialog box appears as follows:

# Hough Transform

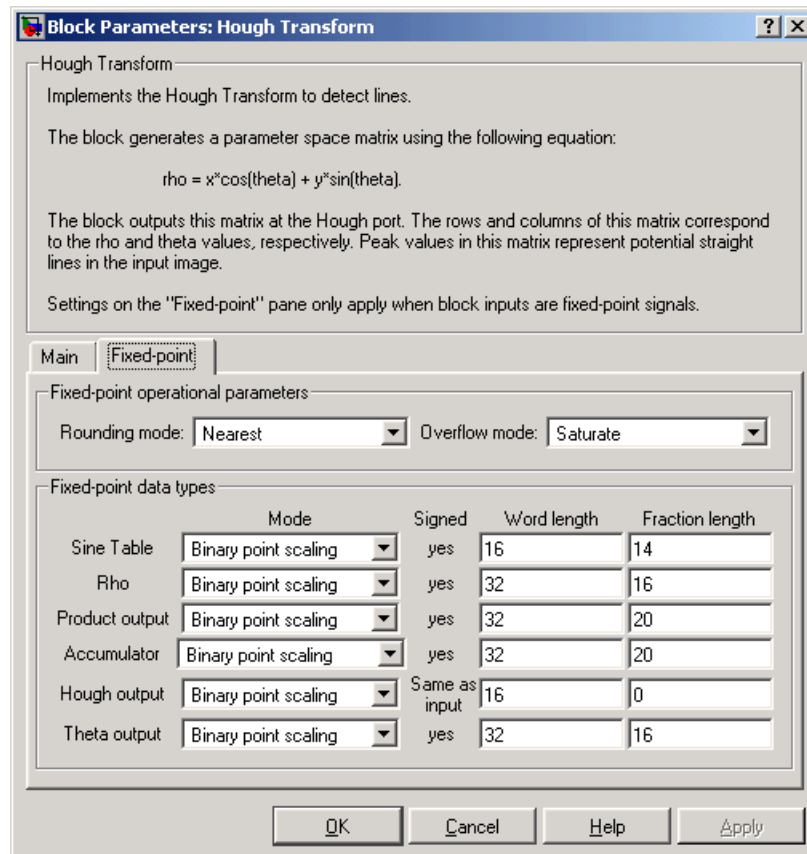

## **Rounding mode**

Select the rounding mode for fixed-point operations.

## **Overflow mode**

Select the overflow mode for fixed-point operations.

## **Sine table**

Choose how you will specify the word length of the values of the sine table:



- When you select Binary point scaling, you can enter the word length of the sine table values, in bits.
- When you select Slope and bias scaling, you can enter the word length of the sine table values, in bits.

The sine table values do not obey the **Rounding mode** and **Overflow mode** parameters; they are always saturated and rounded to Nearest.

## Rho

Choose how you will specify the word length and the fraction length of the rho values:

- When you select Binary point scaling, you can enter the word length and the fraction length of the rho values, in bits.
- When you select Slope and bias scaling, you can enter the word length, in bits, and the slope of the rho values. The bias of all signals in the Video and Image Processing Blockset is zero.

## Product output



As depicted above, the output of the multiplier is placed into the product output data type and scaling. Use this parameter to specify how you would like to designate this product output word and fraction lengths:

- When you select Binary point scaling, you can enter the word length and the fraction length of the product output, in bits.

# Hough Transform

- When you select Slope and bias scaling, you can enter the word length, in bits, and the slope of the product output. The bias of all signals in the Video and Image Processing Blockset is zero.

## Accumulator

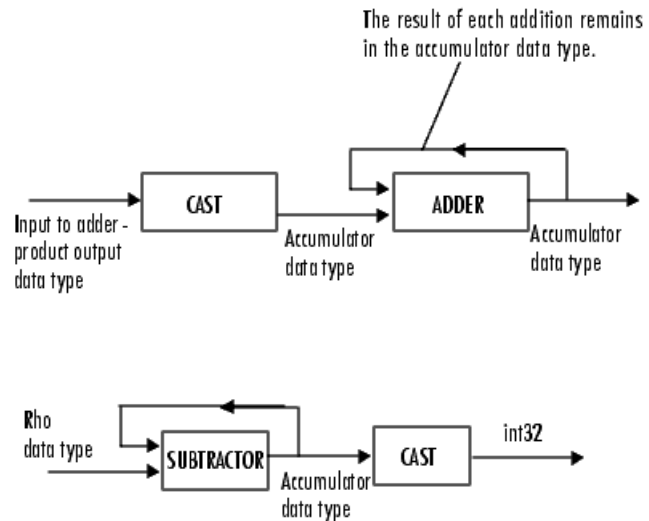

As depicted above, inputs to the accumulator are cast to the accumulator data type. The output of the adder remains in the accumulator data type as each element of the input is added to it. Use this parameter to specify how you would like to designate this accumulator word and fraction lengths:

- When you select Same as product output, these characteristics will match those of the product output.
- When you select Binary point scaling, you can enter the word length and the fraction length of the accumulator, in bits.

- When you select `Slope and bias scaling`, you can enter the word length, in bits, and the slope of the accumulator. The bias of all signals in the Video and Image Processing Blockset is zero.

## Hough output

Choose how you will specify the word length and fraction length of the Hough output of the block:

- When you select `Binary point scaling`, you can enter the word length of the Hough output, in bits. The fraction length is always zero.
- When you select `Slope and bias scaling`, you can enter the word length, in bits, of the Hough output. The slope is always zero. The bias of all signals in the Video and Image Processing Blockset is zero.

## Theta output

Choose how you will specify the word length and fraction length of the theta output of the block:

- When you select `Binary point scaling`, you can enter the word length and the fraction length of the theta output, in bits.
- When you select `Slope and bias scaling`, you can enter the word length, in bits, and the slope of the theta output. The bias of all signals in the Video and Image Processing Blockset is zero.

## See Also

2-D DCT	Video and Image Processing Blockset
2-D FFT	Video and Image Processing Blockset
2-D IDCT	Video and Image Processing Blockset
2-D IFFT	Video and Image Processing Blockset
Find Local Maxima	Video and Image Processing Blockset
Hough Lines	Video and Image Processing Blockset

# Image Complement

**Purpose** Compute the complement of pixel values in binary, intensity, or RGB images

**Library** Conversions

**Description** The Image Complement block computes the complement of a binary, intensity, or RGB image. For binary images, the block replaces pixel values equal to 0 with 1 and pixel values equal to 1 with 0. For an intensity or RGB image, the block subtracts each pixel value from the maximum value that can be represented by the input data type and outputs the difference.



For example, suppose the input pixel values are given by  $x(i)$  and the output pixel values are given by  $y(i)$ . If the data type of the input is double or single precision floating-point, the block outputs  $y(i) = 1.0 - x(i)$ . If the input is an 8-bit unsigned integer, the block outputs  $y(i) = 255 - x(i)$ .

Port	Input/Output	Supported Data Types	Supports Complex Values?
Input	Scalar, vector, or matrix of intensity values or scalar, vector, or matrix that represents one plane of the input RGB video stream	<ul style="list-style-type: none"><li>• Double-precision floating point</li><li>• Single-precision floating point</li><li>• 8-bit unsigned integers</li><li>• Boolean</li></ul>	No
Output	Complement of a binary, intensity, or RGB image	Same as Input port	No

The dimensions, data type, complexity, and frame status of the input and output signals are the same. This block supports a signal represented by a Simulink virtual bus.

## Dialog Box

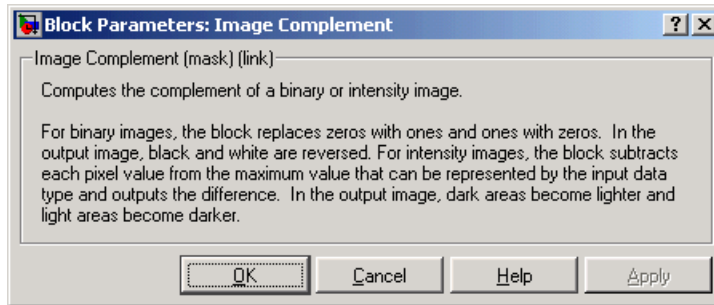

## See Also

[Autothreshold](#)

[Video and Image Processing Blockset](#)

[Chroma Resampling](#)

[Video and Image Processing Blockset](#)

[Color Space Conversion](#)

[Video and Image Processing Blockset](#)

[imcomplement](#)

[Image Processing Toolbox](#)

# Image Data Type Conversion

**Purpose** Convert and scale input image to specified output data type

**Library** Conversions

## Description

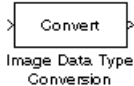

The Image Data Type Conversion block changes the data type of the input to the user-specified data type and scales the values to the new data type's dynamic range. To convert between data types without scaling, use the Simulink Data Type Conversion block.

When converting between floating-point data types, the block casts the input into the output data type and clips values outside the range to 0 or 1. When converting between all other data types, the block casts the input into the output data type and scales the data type values into the dynamic range of the output data type. For double- and single-precision floating-point data types, the dynamic range is between 0 and 1. For fixed-point data types, the dynamic range is between the minimum and maximum values that can be represented by the data type.

Port	Input/Output	Supported Data Types	Supports Complex Values?
Input	Scalar, vector, or matrix of intensity values or scalar, vector, or matrix that represents one plane of the input RGB video stream	<ul style="list-style-type: none"><li>• Double-precision floating point</li><li>• Single-precision floating point</li><li>• Fixed point with word length less than or equal to 16-bit</li></ul>	No
Output	Scalar, vector, or matrix with values that are the specified data type	Same as Input port	No

The dimensions, complexity, and frame status of the input and output signals are the same. This block supports a signal represented by a Simulink virtual bus.

Use the **Output data type** parameter to specify the data type of your output signal values.

## Dialog Box

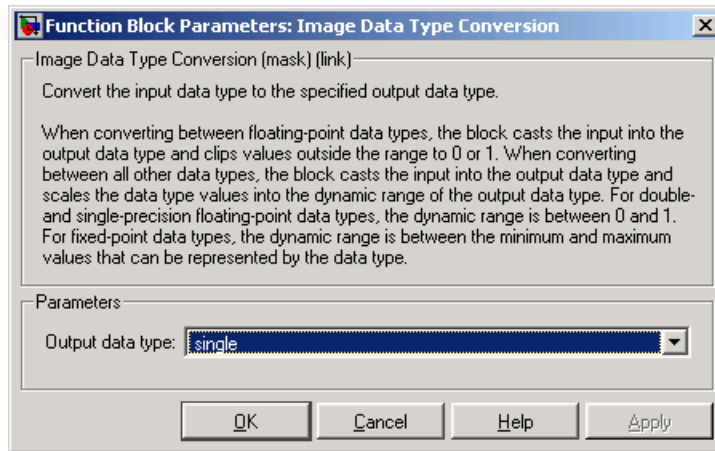

### Output data type

Use this parameter to specify the data type of your output signal.

# Image Data Type Conversion

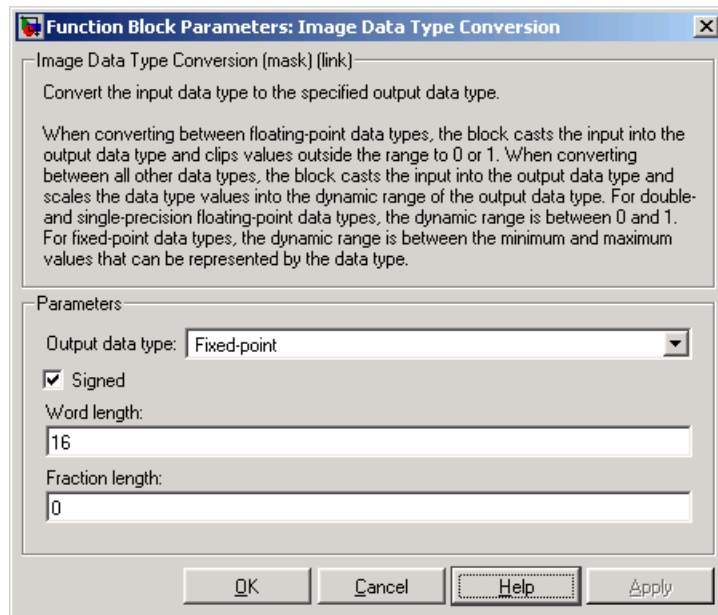

## Signed

Select this check box if you want the output fixed-point data to be signed. This parameter is visible if, for the **Output data type** parameter, you choose Fixed-point.

## Word length

Use this parameter to specify the word length of your fixed-point output. This parameter is visible if, for the **Output data type** parameter, you choose Fixed-point.

## Fraction length

Use this parameter to specify the fraction length of your fixed-point output. This parameter is visible if, for the **Output data type** parameter, you choose Fixed-point.

## See Also

Autothreshold

Video and Image Processing Blockset



**Purpose** Import image from image file

**Library** Sources

## Description

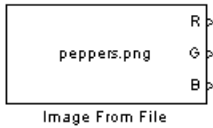

Use the Image From File block to import an image from a supported image file. For a list of supported file formats, see the `imread` function reference page in the Image Processing Toolbox documentation. If the image is a M-by-N array, the block outputs a binary or intensity image, where M and N are the number of rows and columns in the image. If the image is a M-by-N-by-3 array, the block outputs a color image, where M and N are the number of rows and columns in each color plane.

Port	Output	Supported Data Types	Supports Complex Values?
I	Scalar, vector, or matrix of intensity values	<ul style="list-style-type: none"> <li>• Double-precision floating point</li> <li>• Single-precision floating point</li> <li>• Fixed point</li> </ul>	Yes
R, G, B	Scalar, vector, or matrix that represents one plane of the input RGB video stream. Outputs from the R, G, or B ports have same dimensions.	Same as port I	Yes

For Video and Image Processing Blockset blocks to display video data properly, double- and single-precision floating- point pixel values must be between 0 and 1. If the input pixel values have a different data type than the one you select using the **Output data type** parameter, the block scales and/or adds an offset to the pixel values so that they are within the dynamic range of their new data type.

Use the **File name** parameter to specify the name of the graphics file that contains the image to import into Simulink. If the file is not on the MATLAB path, use the **Browse** button to locate the file. This parameter supports URL paths.

# Image From File

---

Use the **Sample time** parameter to set the sample period of the output signal.

Use the **Output port labels** parameter to label your output ports. Use the spacer character, |, as the delimiter.

On the **Data Types** pane, use the **Output data type** parameter to specify the data type of your output signal.

## Dialog Box

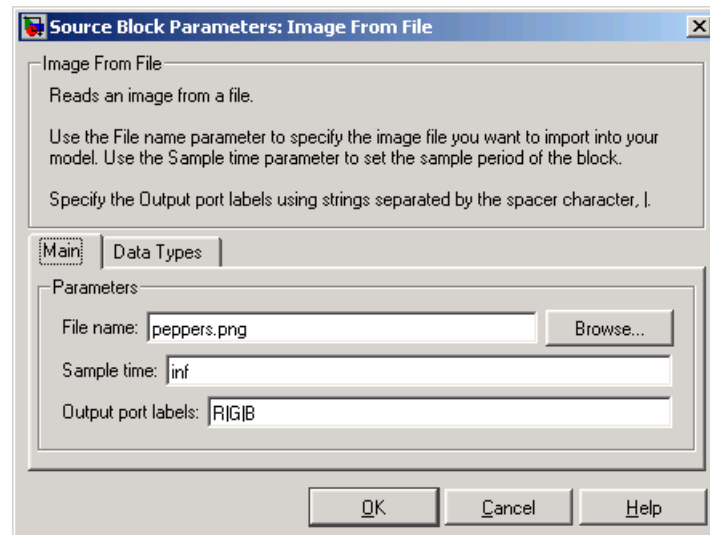

### File name

Specify the name of the graphics file that contains the image to import into Simulink.

### Sample time

Enter the sample period of the output signal.

### Output port labels

Enter the labels for your output ports using the spacer character, |, as the delimiter.

The **Data Types** pane of the Image From File block dialog appears as follows:

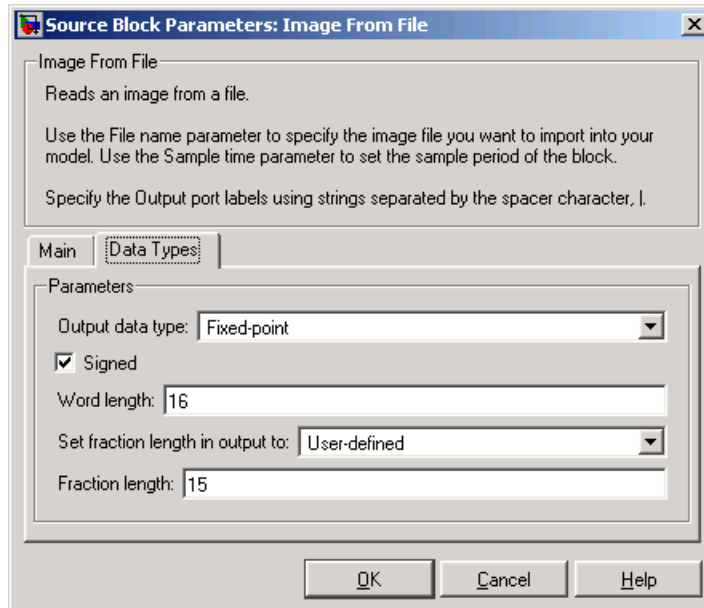

## Output data type

Specify the data type of your output signal.

## Signed

Select to output a signed fixed-point signal. Otherwise, the signal will be unsigned. This parameter is only visible if, from the **Output data type** list, you select Fixed-point.

## Word length

Specify the word length, in bits, of the fixed-point output data type. This parameter is only visible if, from the **Output data type** list, you select Fixed-point.

# Image From File

---

## **Set fraction length in output to**

Specify the scaling of the fixed-point output by either of the following two methods:

- Choose **Best precision** to have the output scaling automatically set such that the output signal has the best possible precision.
- Choose **User-defined** to specify the output scaling in the **Fraction length** parameter.

This parameter is only visible if, from the **Output data type** list, you select **Fixed-point** or when you select **User-defined**.

## **Fraction length**

For fixed-point output data types, specify the number of fractional bits, or bits to the right of the binary point. This parameter is only visible when you select **Fixed-point** or **User-defined** for the **Output data type** parameter and **User-defined** for the **Set fraction length in output to** parameter.

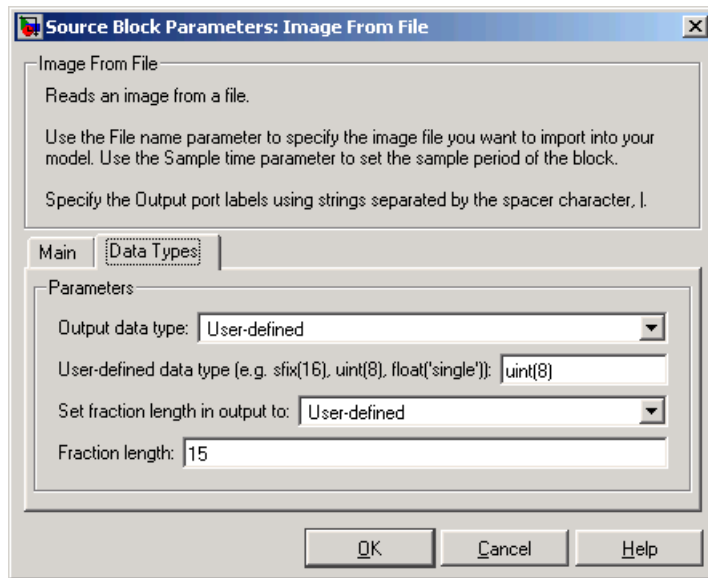

## User-defined data type

Specify any built-in or fixed-point data type. You can specify fixed-point data types using the `sfixed`, `ufixed`, `sint`, `uint`, `sfrac`, and `uffrac` functions from Simulink Fixed Point. This parameter is only visible when you select User-defined for the **Output data type** parameter.

## See Also

From Multimedia File	Video and Image Processing Blockset
Image From Workspace	Video and Image Processing Blockset
To Video Display	Video and Image Processing Blockset
Video From Workspace	Video and Image Processing Blockset
Video Viewer	Video and Image Processing Blockset

# Image From File

---

`im2double`

Image Processing Toolbox

`im2uint8`

Image Processing Toolbox

`imread`

Image Processing Toolbox

**Purpose** Import image from MATLAB workspace

**Library** Sources

**Description**

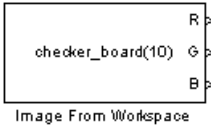

Use the Image From Workspace block to import an image from the MATLAB workspace. If the image is a M-by-N workspace array, the block outputs a binary or intensity image, where M and N are the number of rows and columns in the image. If the image is a M-by-N-by-3 workspace array, the block outputs a color image, where M and N are the number of rows and columns in each color plane.

Port	Output	Supported Data Types	Supports Complex Values?
I	Scalar, vector, or matrix of intensity values	<ul style="list-style-type: none"> <li>• Double-precision floating point</li> <li>• Single-precision floating point</li> <li>• Fixed point</li> </ul>	No
R, G, B	Scalar, vector, or matrix that represents one plane of the RGB video stream. Outputs from the R, G, or B ports have same dimensions.	Same as port I	No

For Video and Image Processing Blockset blocks to display video data properly, double- and single-precision floating- point pixel values must be between 0 and 1. If the input pixel values have a different data type than the one you select using the **Output data type** parameter, the block scales and/or adds an offset to the pixel values so that they are within the dynamic range of their new data type.

Use the **Value** parameter to specify the MATLAB workspace variable that contains the image you want to import into Simulink.

Use the **Sample time** parameter to set the sample period of the output signal.

# Image From Workspace

---

Use the **Output port labels** parameter to label your output ports. Use the spacer character, |, as the delimiter.

On the **Data Types** pane, use the **Output data type** parameter to specify the data type of your output signal.

## Dialog Box

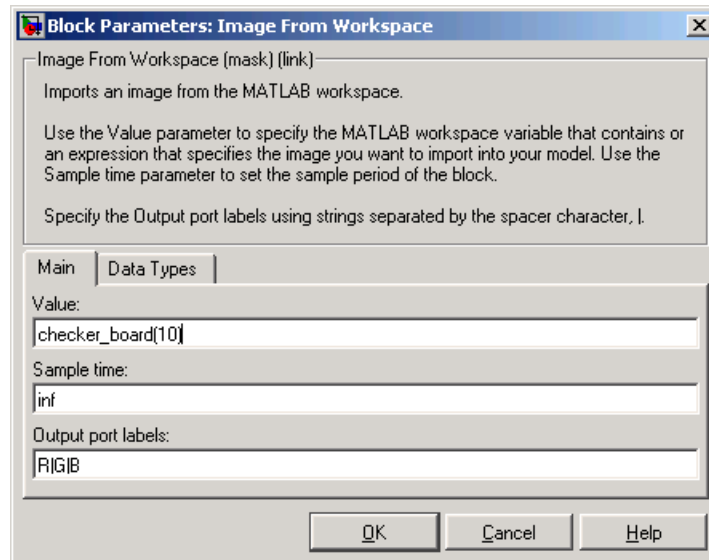

### Value

Specify the MATLAB workspace variable that you want to import into Simulink.

### Sample time

Enter the sample period of the output signal.

### Output port labels

Enter the labels for your output ports using the spacer character, |, as the delimiter.

The **Data Types** pane of the Image From Workspace block dialog appears as follows:



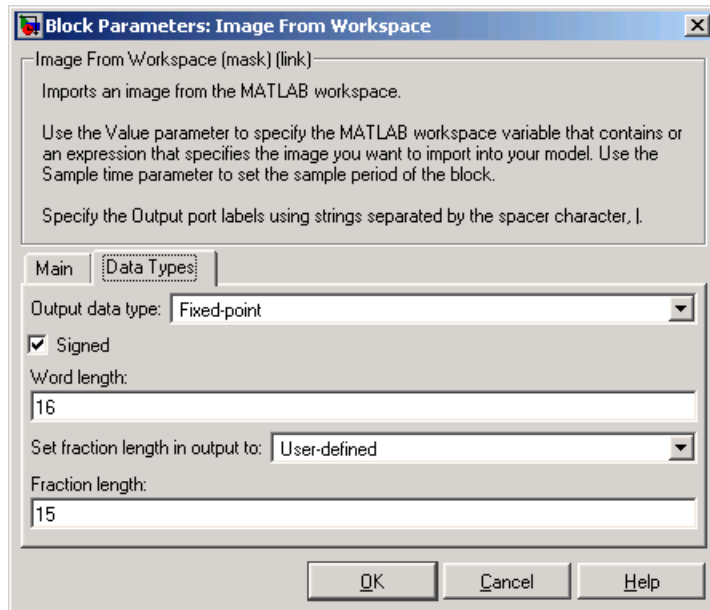

## Output data type

Specify the data type of your output signal.

## Signed

Select to output a signed fixed-point signal. Otherwise, the signal will be unsigned. This parameter is only visible if, from the **Output data type** list, you select Fixed-point.

## Word length

Specify the word length, in bits, of the fixed-point output data type. This parameter is only visible if, from the **Output data type** list, you select Fixed-point.

## Set fraction length in output to

Specify the scaling of the fixed-point output by either of the following two methods:

# Image From Workspace

- Choose **Best** precision to have the output scaling automatically set such that the output signal has the best possible precision.
- Choose **User-defined** to specify the output scaling in the **Fraction length** parameter.

This parameter is only visible if, from the **Output data type** list, you select **Fixed-point** or when you select **User-defined**.

## Fraction length

For fixed-point output data types, specify the number of fractional bits, or bits to the right of the binary point. This parameter is only visible when you select **Fixed-point** or **User-defined** for the **Output data type** parameter and **User-defined** for the **Set fraction length in output to** parameter.

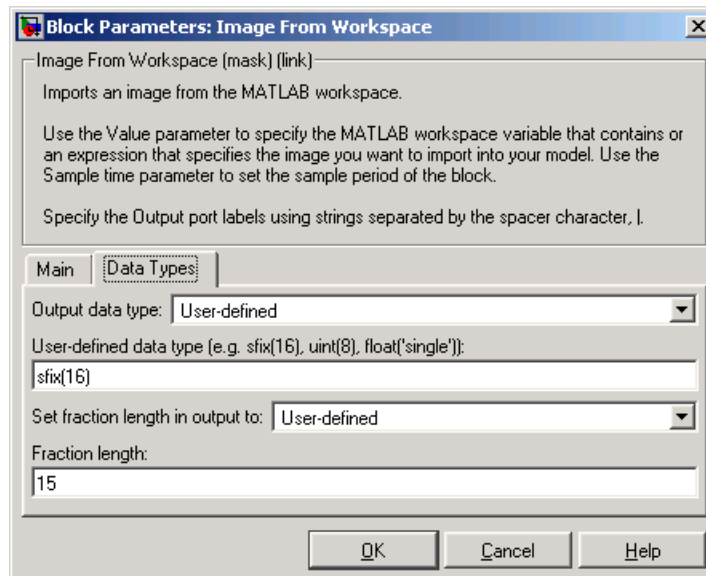

## User-defined data type

Specify any built-in or fixed-point data type. You can specify fixed-point data types using the `sfix`, `ufix`, `sint`, `uint`, `sfrac`, and `ufrac` functions from Simulink Fixed Point. This parameter is only visible when you select User-defined for the **Output data type** parameter.

## See Also

From Multimedia File	Video and Image Processing Blockset
To Video Display	Video and Image Processing Blockset
Video From Workspace	Video and Image Processing Blockset
Video Viewer	Video and Image Processing Blockset
<code>im2double</code>	Image Processing Toolbox
<code>im2uint8</code>	Image Processing Toolbox

# Insert Text

**Purpose** Draw text on image or video stream

**Library** Text & Graphics

**Description** The Insert Text block draws formatted text or numbers on an image or video stream. The block uses the FreeType library, an open-source font engine, to produce stylized text bitmaps. To learn more about The FreeType Project, visit <http://www.freetype.org/>.

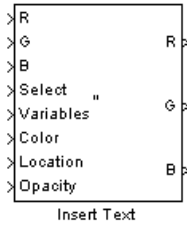

Port	Input/Output	Supported Data Types	Supports Complex Values?
I	Matrix of intensity values	<ul style="list-style-type: none"><li>• Double-precision floating point</li><li>• Single-precision floating point</li><li>• 8-bit unsigned integers</li></ul>	No
R, G, B	Matrix that represents one plane of the RGB video stream. Outputs from the R, G, or B ports have same dimensions and data type.	Same as port I	No
Select	Scalar value that indicates which text string to display	<ul style="list-style-type: none"><li>• Double-precision floating point</li></ul>	No

Port	Input/Output	Supported Data Types	Supports Complex Values?
Variables	Vector whose values are used to replace ANSI C printf-style format specifications	<ul style="list-style-type: none"> <li>• Double-precision floating point</li> <li>• Single-precision floating point</li> <li>• 8-, 16-, 32-bit signed integers</li> <li>• 8-, 16-, 32-bit unsigned integers</li> <li>• Boolean</li> </ul>	No
Location	Two-element vector of the form [row column], which represents the top left corner of the text bounding box	<ul style="list-style-type: none"> <li>• Double-precision floating point</li> </ul>	No
Intensity	Scalar that represents the intensity value of the text. Input must be the same data type as port I.	<ul style="list-style-type: none"> <li>• Same as port I</li> </ul>	No
Color	Three-element vector that specifies the RGB triplet value for the text. Input must be the same data type as ports R, G, and B.	<ul style="list-style-type: none"> <li>• Same as port I</li> </ul>	No
Opacity	Scalar that indicates the text's opaqueness	<ul style="list-style-type: none"> <li>• Double-precision floating point</li> </ul>	No

Use the **Input type** parameter to specify the input to the block. If the block input is an RGB image or video stream, select RGB. If the block input is an intensity image or video stream, select Intensity.

Use the **Text** parameter to specify the text string to be drawn on the image or video frame. This parameter can be a single text string, such as 'Figure1', or a cell array of strings, such as {'Figure1'}, {'Figure2'}.

## Insert Text

---

If, for the **Text** parameter, you enter a cell array of strings, the **Select** port appears on the block. The input to this port must be a scalar value that indicates which text string to display, where 1 indicates the first string. If the input is less than 1 or greater than the number of strings in the cell array, the block does not draw text on the image or video frame.

If, for the **Text** parameter, you enter ANSI C printf-style format specifications, such as `%d`, `%f`, or `%s`, the **Variables** port appears on the block. The block replaces the format specifications in the **Text** parameter with each element of the input vector in turn. If you use the `%s` format specification, the input to the **Variables** port must be a vector of 8-bit unsigned integers. The block treats this input as one null-terminated C-style character string

Use the **Location source** parameter to indicate where you want to specify the text location. If you select **Specify via dialog**, the **Location ([row column])** parameter appears on the dialog. Enter a two-element vector of the form `[row column]`, which indicates the top left corner of the text bounding box. You can enter negative values or values that exceed the dimensions of the input image or video frame, but the text might not be visible. If, for the **Location source** parameter, you select **Input port**, the **Location** port appears on the block. The input to this port must be a two-element vector as described for the **Location ([row column])** parameter.

If, for the **Input type** parameter, you select **RGB**, the **Color source** parameter appears on the dialog. Use this parameter to indicate where you want to specify the text color. If you select **Specify via dialog**, the **Color ([R G B])** parameter appears on the dialog. Enter an RGB triplet that specifies the color of the text. If the input RGB image is floating point, the values must be between 0 and 1. If the input RGB image is composed of 8-bit unsigned integers, the values must range between 0 and 255. If, for the **Color source** parameter, you select **Input port**, the **Color** port appears on the block. The input to this port must be a three-element vector that specifies the RGB triplet value for the text.

If, for the **Input type** parameter, you select **Intensity**, the **Intensity source** parameter appears on the dialog. Use this parameter to indicate where you want to specify the text intensity. If you select **Specify via**

dialog, the **Intensity** parameter appears on the dialog. Enter a scalar that represents the intensity value of the text. If the input intensity image is floating point, the value must be between 0 and 1. If the input intensity image is composed of 8-bit unsigned integers, the value must range between 0 and 255. If, for the **Intensity source** parameter, you select Input port, the Intensity port appears on the block. The input to this port must be a scalar as described for the **Intensity** parameter.

Use the **Opacity source** parameter to indicate where you want to specify the text's opaqueness. If you select Specify via dialog, the **Opacity** parameter appears on the dialog. Enter a scalar between 0 and 1, where 0 is translucent and 1 is opaque. If, for the **Opacity source** parameter, you select Input port, the Opacity port appears on the block. The input to this port must be a scalar as described for the **Opacity** parameter.

On the **Font** pane, use the **Font face** parameter to specify the font of your text. The block populates this list with the TrueType fonts installed on your system. On Windows, the block searches the system registry for font files. On UNIX, the block searches the X Server's font path for font files.

Use the **Font size (points)** parameter to specify the font size.

If you select the **Anti-aliased** check box, the block smoothes the edges of the text, which can be computationally expensive. If you want your model to run faster, clear this check box.

# Insert Text

## Dialog Box

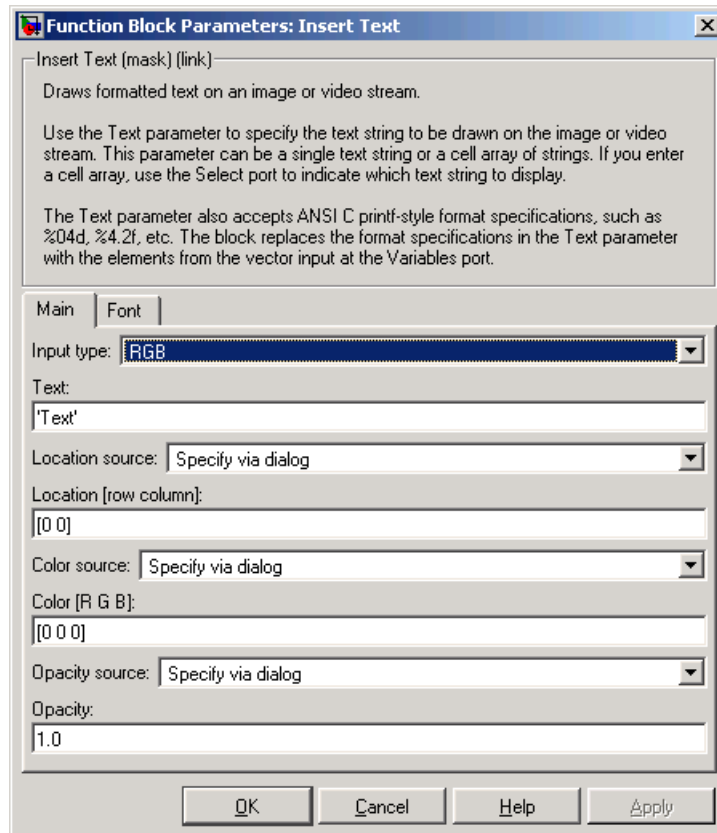

### Input type

Specify the input to the block. If the block input is an RGB image or video stream, select RGB. If the block input is an intensity image or video stream, select Intensity.

### Text

Specify the text string to be drawn on the image or video stream. This parameter can be a single text string or a cell array of strings.



**Location source**

Indicate where you want to specify the text location. Your choices are Specify via dialog or Input port.

**Location ([row column])**

Enter a two-element vector of the form [row column], which indicates the top left corner of the text bounding box. This parameter is visible if, for the **Text location source** parameter, you select Specify via dialog.

**Color source**

Indicate where you want to specify the text color. Your choices are Specify via dialog or Input port. This parameter is visible if, for the **Input type** parameter, you select RGB.

**Color ([R G B])**

Enter an RGB triplet that specifies the color of the text. If the input RGB image is floating point, the values must be between 0 and 1. If the input RGB image is composed of 8-bit unsigned integers, the values must range between 0 and 255. This parameter is visible if, for the **Text color source** parameter, you select Specify via dialog.

**Intensity source**

Indicate where you want to specify the text intensity. Your choices are Specify via dialog or Input port. This parameter is visible if, for the **Input type** parameter, you select Intensity.

**Intensity**

Enter a scalar that represents the intensity value of the text. If the input intensity image is floating point, the value must be between 0 and 1. If the input intensity image is composed of 8-bit unsigned integers, the value must range between 0 and 255. This parameter is visible if, for the **Text intensity source** parameter, you select Specify via dialog.

**Opacity source**

Indicate where you want to specify the text's opaqueness. Your choices are Specify via dialog or Input port.

# Insert Text

---

## Opacity

Enter a scalar between 0 and 1, where 0 is translucent and 1 is opaque. This parameter is visible if, for the **Text opacity source** parameter, you select Specify via dialog.

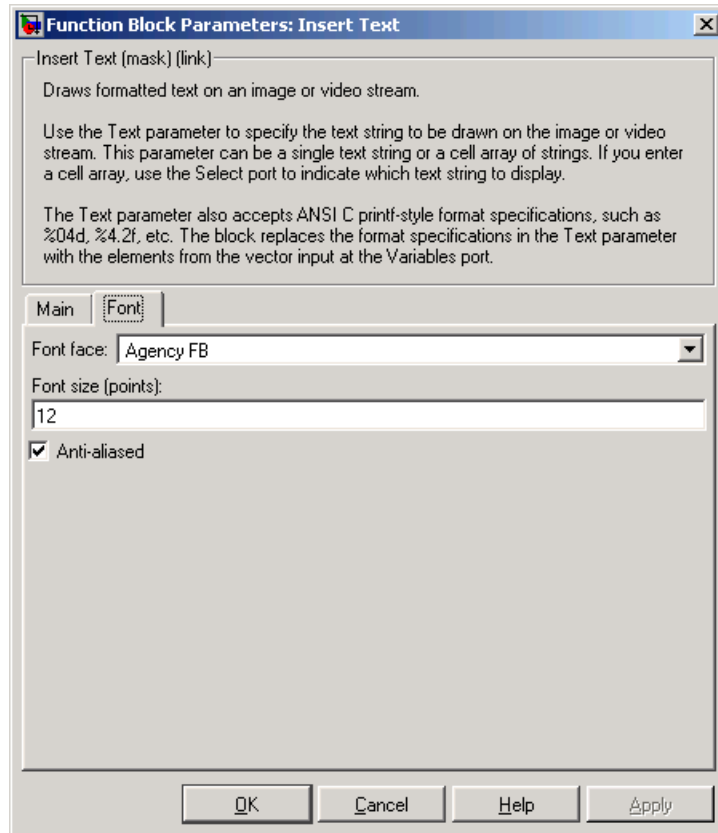

## Font face

Specify the font of your text. The block populates this list with the fonts installed on your system.

## Font size (points)

Specify the font size.

## **Anti-aliased**

If you select this check box, the block smooths the edges of the text, which can be computationally expensive. If you want your model to run faster, clear this check box.

## **See Also**

[Draw Shapes](#)

[Video and Image Processing Blockset](#)

# Label

**Purpose** Label connected components in binary images

**Library** Morphological Operations

## Description



The Label block labels the objects in a binary image, BW, where the background is represented by pixels equal to 0 (black) and objects are represented by pixels equal to 1 (white). At the Label port, the block outputs a label matrix that is the same size as the input matrix. In the label matrix, pixels equal to 0 represent the background, pixels equal to 1 represent the first object, pixels equal to 2 represent the second object, and so on. At the Count port, the block outputs a scalar that represents the number of labeled objects.

Port	Input/Output	Supported Data Types	Supports Complex Values?
BW	Scalar, vector, or matrix that represents a binary image	<ul style="list-style-type: none"><li>• Boolean</li></ul>	No
Label	Label matrix	<ul style="list-style-type: none"><li>• 8-, 16-, and 32-bit unsigned integers</li></ul>	No
Count	Scalar that represents the number of labeled objects	Same as Label port	No

Use the **Connectivity** parameter to define which pixels are connected to each other. If you want a pixel to be connected to the other pixels located on the top, bottom, left, and right, select 4. If you want a pixel to be connected to the other pixels on the top, bottom, left, right, and diagonally, select 8.

Consider the 3-by-3 image shown below. If, for the **Connectivity** parameter, you select 4, the block considers the white pixels marked by black circles to be connected.

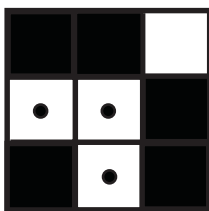

If, for the **Connectivity** parameter, you select 8, the block considers the white pixels marked by black circles to be connected.

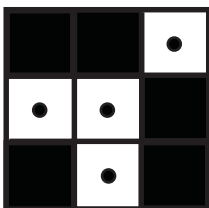

Use the **Output** parameter to determine the block's output. If you select `Label matrix` and `number of labels`, ports `Label` and `Count` appear on the block. The block outputs the label matrix at the `Label` port and the number of labeled objects at the `Count` port. If you select `Label matrix`, the `Label` port appears on the block. If you select `Number of labels`, the `Count` port appears on the block.

Use the **Output data type** parameter to set the data type of the outputs at the `Label` and `Count` ports. If you select `Automatic`, the block determines the minimum data type size that guarantees unique region labels and sets the output data type appropriately. If you select `uint32`, `uint16`, or `uint8`, the data type of the output is 32-, 16-, or 8-bit unsigned integers, respectively. If you select `uint16`, or `uint8`, the **If label exceeds data type size, mark remaining regions using** parameter appears on the dialog box. If the number of found objects exceeds the maximum number that can be represented by the output data type, use this parameter to specify the block's behavior. If you select `Maximum value of the output data type`, the remaining

# Label

regions are labeled with the maximum value of the output data type. If you select Zero, the remaining regions are labeled with zeroes.

## Dialog Box

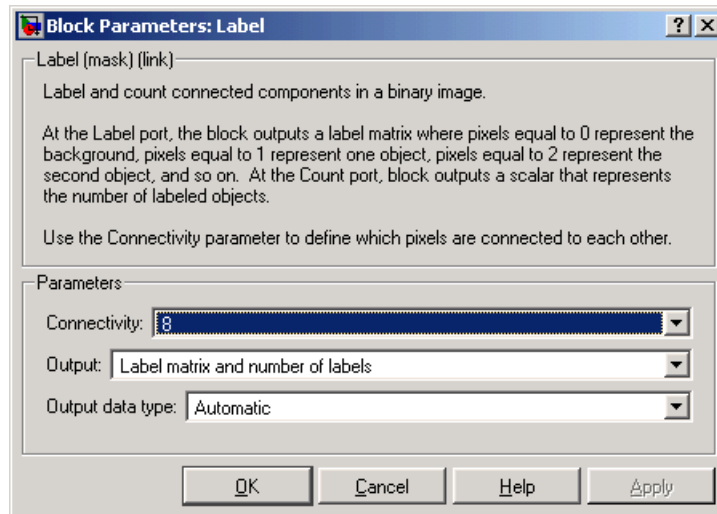

### Connectivity

Specify which pixels are connected to each other. If you want a pixel to be connected to the pixels on the top, bottom, left, and right, select 4. If you want a pixel to be connected to the pixels on the top, bottom, left, right, and diagonally, select 8.

### Output

Determine the block's output. If you select `Label matrix and number of labels`, the `Label` and `Count` ports appear on the block. The block outputs the label matrix at the `Label` port and the number of labeled objects at the `Count` port. If you select `Label matrix`, the `Label` port appears on the block. If you select `Number of labels`, the `Count` port appears on the block.

### Output data type

Set the data type of the outputs at the `Label` and `Count` ports. If you select `Automatic`, the block determines the appropriate

data type for the output. If you select `uint32`, `uint16`, or `uint8`, the data type of the output is 32-, 16-, or 8-bit unsigned integers, respectively.

**If label exceeds data type size, mark remaining regions using**

Use this parameter to specify the block's behavior if the number of found objects exceeds the maximum number that can be represented by the output data type. If you select `Maximum` value of the output data type, the remaining regions are labeled with the maximum value of the output data type. If you select `Zero`, the remaining regions are labeled with zeroes. This parameter is visible if, for the **Output data type** parameter, you choose `uint16` or `uint8`.

## See Also

Bottom-hat	Video and Image Processing Blockset
Closing	Video and Image Processing Blockset
Dilation	Video and Image Processing Blockset
Erosion	Video and Image Processing Blockset
Opening	Video and Image Processing Blockset
Top-hat	Video and Image Processing Blockset
<code>bwlabel</code>	Image Processing Toolbox
<code>bwlabeln</code>	Image Processing Toolbox

**Purpose** View video from MATLAB workspace, file, or Simulink model

**Library** Sinks

**Description** Use the MPlay block GUI to view videos from files or the MATLAB workspace. You can also use it to view video signals in Simulink models. If the video contains audio, the GUI ignores it and plays only the video frames.













This reference page contains the following sections:











- “MPlay Block GUI Buttons” on page 9-302
- “Viewing Videos from the MATLAB Workspace” on page 9-304
- “Viewing Video Files” on page 9-306
- “Viewing Video Signals in Simulink” on page 9-307
- “Preferences Dialog Box” on page 9-309
- “Video Information Dialog Box” on page 9-310
- “Colormap Dialog Box” on page 9-311
- “Frame Rate Dialog Box” on page 9-312

### **MPlay Block GUI Buttons**

The following table summarizes the behavior of the MPlay block GUI buttons.



Button	Menu Equivalent	Shortcut Keys and Accelerators	Description
	<b>File</b> → <b>New MPlay</b>	<b>Ctrl+N</b>	Open a new MPlay block GUI.
	<b>File</b> → <b>Open</b>	<b>Ctrl+O</b>	Connect to a video file.
	<b>File</b> → <b>Import from Workspace</b>	<b>Ctrl+I</b>	Connect to a video that is a variable in the MATLAB workspace.
	<b>File</b> → <b>Connect to Simulink Signal</b>	<b>Ctrl+S</b>	Connect to a Simulink signal.
	<b>File</b> → <b>Export to Image Tool</b>	<b>Ctrl+E</b>	Send the current video frame to the Image Tool. For more information, see <a href="#">Using the Image Tool to Explore Images in the Image Processing Toolbox documentation</a> .
	<b>Tools</b> → <b>Video Information</b>	I	View information about the video data source.
	<b>View</b> → <b>True Size</b>	N/A	Set the size of the MPlay window so that one screen pixel represents one video pixel.
	<b>View</b> → <b>Zoom In</b>	N/A	Zoom in on the video display.
	<b>View</b> → <b>Zoom Out</b>	N/A	Zoom out of the video display.
	<b>Playback</b> → <b>Go to First</b>	F, Home	Go to the first frame of the video.
	<b>Playback</b> → <b>Rewind</b>	Up arrow	Jump back 10 frames.

Button	Menu Equivalent	Shortcut Keys and Accelerators	Description
	<b>Playback</b> → <b>Step Back</b>	Left arrow, Page up	Step back one frame.
	<b>Playback</b> → <b>Stop</b>	S	Stop the video.
	<b>Playback</b> → <b>Play</b>	P, Space bar	Play the video.
	<b>Playback</b> → <b>Pause</b>	P, Space bar	Pause the video. This button is visible only when the video is playing.
	<b>Playback</b> → <b>Step Forward</b>	Right arrow, Page down	Step forward one frame.
	<b>Playback</b> → <b>Fast Forward</b>	Down arrow	Jump forward 10 frames.
	<b>Playback</b> → <b>Go to Last</b>	L, End	Go to the last frame of the video.
	<b>Playback</b> → <b>Jump to</b>	J	Jump to a specific frame.
	<b>Playback</b> → <b>Repeat</b>	R	Continue playing the video.
	<b>Playback</b> → <b>Autoreverse</b>	A	Play the video once forward and once backward.

## Viewing Videos from the MATLAB Workspace

The MPlay block GUI enables you to view videos that are represented as variables in the MATLAB workspace, such as video data exported to

the workspace by the Video To Workspace block. The following example shows you how to use the MPlay block GUI to view such a video:

- 1 Define a variable that represents a video sequence in the MATLAB workspace. For example, to read an entire video into memory, type

```
m = aviread('viplane.avi');
```

at the MATLAB command prompt.

- 2 Connect the MPlay block GUI to the variable in the MATLAB

workspace by either typing `mplay(m)` or clicking . In the Load expression dialog box, for the **Expression** parameter, enter `m`. Click **OK**.

The first frame of the video appears in the MPlay window.

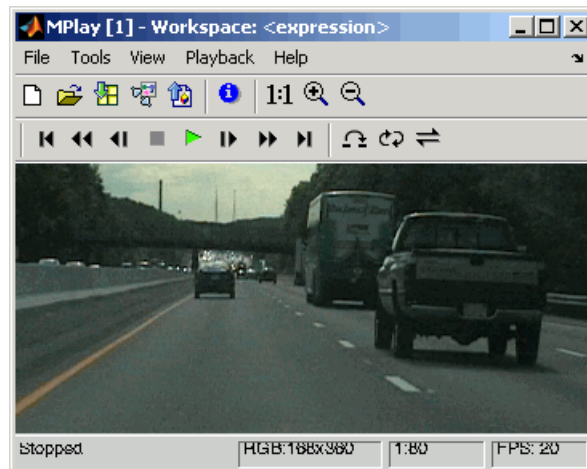

---

**Note** The MPlay block GUI supports MATLAB variables that are in the movie structure array format. It also supports three-dimensional and four-dimensional arrays, which it interprets as intensity and RGB videos, respectively. You can use a function or any statement that can be evaluated for the **Expression** parameter.

---

- 3 Experiment with using the MPlay block GUI to play and interact with the video sequence. By default, the GUI assumes that the video data has a frame rate of 20 frames per second (fps).

### Viewing Video Files

The MPlay block GUI enables you to view videos from files without having to load all the video data at once. The following example shows you how to use the MPlay block GUI to view a video one frame at a time.

- 1 Click .
- 2 Use the Pick a file dialog box to navigate to the multimedia file you want to view in the MPlay window. For example, navigate to `$matlabroot\toolbox\vipblks\vipdemos\vipmen.avi`. Click **Open**.

The first frame of the video appears in the MPlay window.

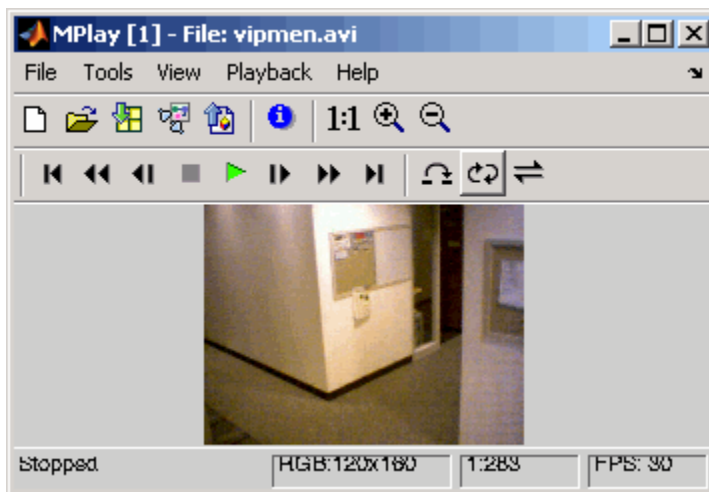

---

**Note** The MPlay block GUI supports AVI files that are supported by the `aviread` function.

---

- 3 Experiment with using the MPlay block GUI to play and interact with the video stream.

### Viewing Video Signals in Simulink

The MPlay block GUI enables you to view video signals in Simulink models without adding blocks to your model. The following example shows you how to use the MPlay block GUI to view a Simulink signal.

- 1 Open a Simulink model. At the MATLAB command prompt, type  

```
viprotate
```

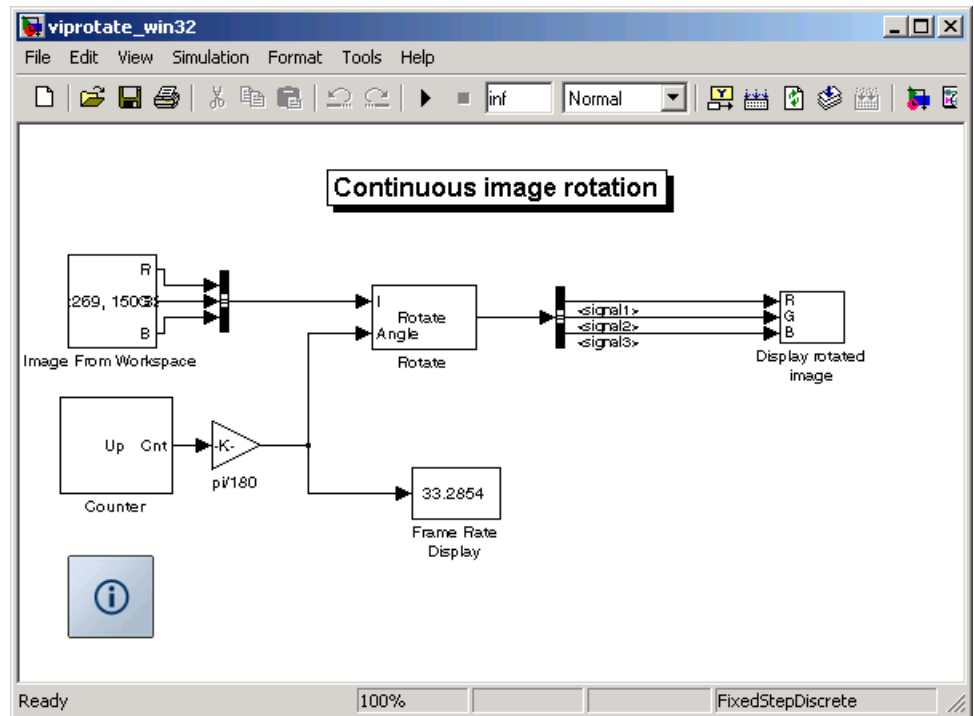

- 2 Run the model.
- 3 Select the signal line you want to view. For example, select the three lines connected to the Display rotated image block or the bus signal coming out of the Rotate block.
- 4 On the MPlay block GUI, click .

The video appears in the MPlay window.

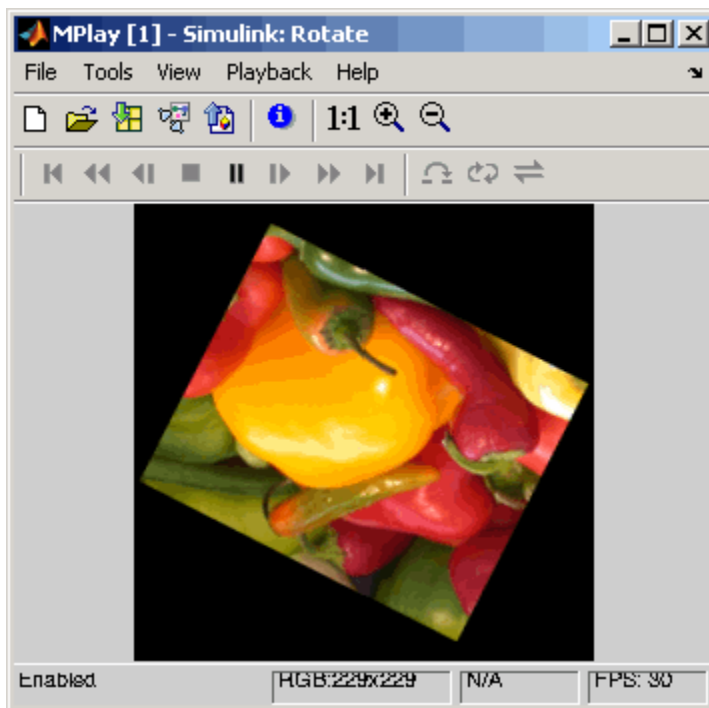

- 5 Experiment with selecting different signals and viewing them in the MPlay window. Note that each time you select a signal, you must click the Connect to Simulink signal button, . Also, if the Simulink model stops, you must reestablish the connection with the MPlay block GUI when you restart it. You can only connect the GUI to a running model.

### Preferences Dialog Box

The Preferences dialog box enables you to change the behavior and appearance of the GUI and the behavior of the playback shortcut keys. To access this dialog, from the **File** menu, select **Preferences** or press **N**.

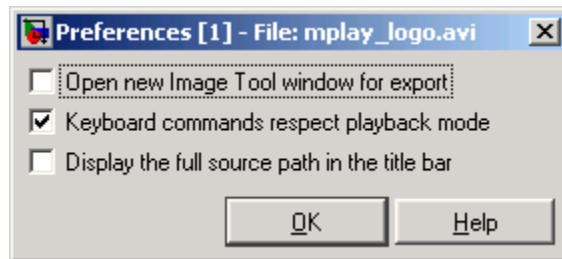

Select the **Open new Image Tool window for export** check box if you want to send each video frame to a different session of Image Tool.

If you select the **Keyboard commands respect playback mode** check box, the keyboard shortcut keys are aware of whether or not you selected Repeat or Autoreverse for the playback mode. If you clear this check box, the keyboard shortcut keys always behave as if the video is playing with Repeat and Autoreverse set to “off.”

If you select the **Display the full source path in the title bar** check box, the GUI displays the full path to the video data source in the title bar. Otherwise, it only displays a shortened name.

### **Video Information Dialog Box**

The Video Information dialog box enables you to view basic information about the video. To access this dialog, from the **Tools** menu, select

**Video Information** or click  .



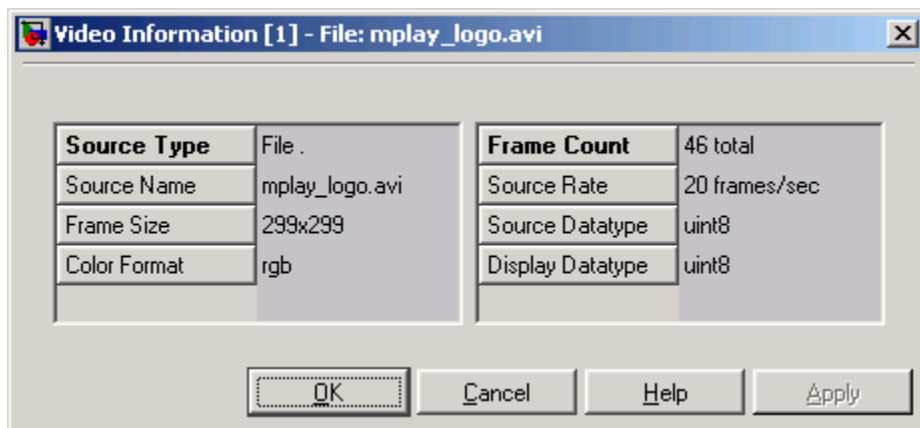

### Colormap Dialog Box

The Colormap dialog box enables you to change the colormap of an intensity video. The parameters on this dialog box are not available when the GUI is displaying RGB video data. To access this dialog, from the **Tools** menu, select **Colormap** or press **C**.

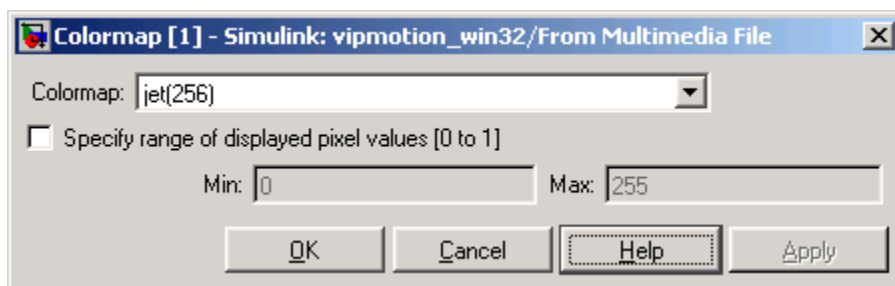

Use the **Colormap** parameter to specify the colormap to apply to the intensity video.

If you know that the pixel values do not use the entire data type range, you can select the **Specify range of displayed pixel values** check box and enter the range for your data.

## Frame Rate Dialog Box

The Frame Rate dialog box enables you to change the rate at which the MPlay block GUI plays the video. The GUI might drop frames to achieve the frame rate you specify. This option is not available if you are using the MPlay block GUI to view a video signal in a Simulink model. To access this dialog, from the **Tools** menu, select **Frame Rate** or press **T**.

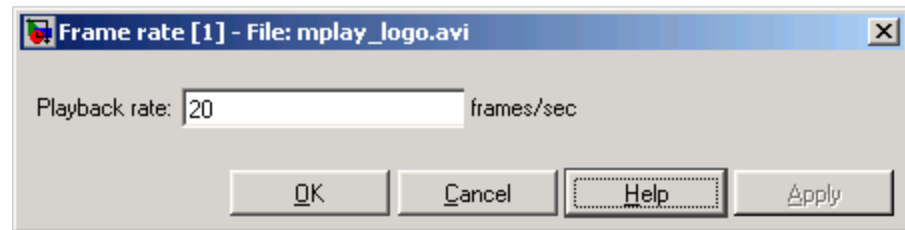

## GUI Interface

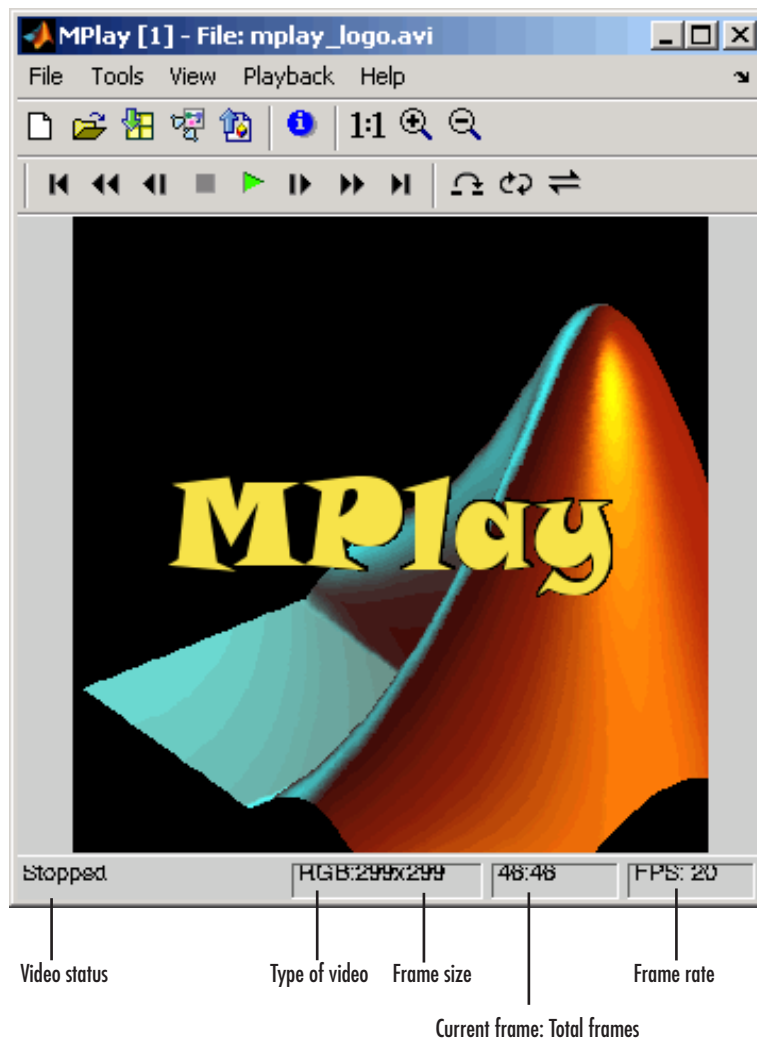

---

**Note** You can open several instances of the MPlay block GUI simultaneously to view multiple video data sources at once. You can also dock these MPlay block GUIs in the MATLAB desktop. Use the figure arrangement buttons in the upper-right corner of the Sinks window to control the placement of the docked GUIs.

---

## See Also

To Multimedia File	Video and Image Processing Blockset
To Video Display	Video and Image Processing Blockset
Video To Workspace	Video and Image Processing Blockset
Video Viewer	Video and Image Processing Blockset

**Purpose** Perform two-dimensional median filtering

**Library** Filtering / Analysis & Enhancement

## Description

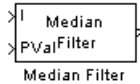

The Median Filter block replaces the central value of an M-by-N neighborhood with its median value. If the neighborhood has a center element, the block places the median value there, as illustrated below.

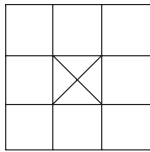

If the neighborhood does not have an exact center, the block has a bias toward the upper left corner and places the median value there, as illustrated below.

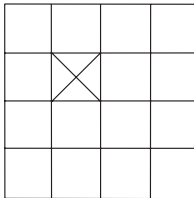

The block pads the edge of the input image so, pixels within  $[M/2 \ N/2]$  of the edges may appear distorted. Because the median value is less sensitive than the mean to extreme values, the Median Filter block can remove salt and pepper noise from an image without significantly reducing the sharpness of the image.

# Median Filter

Port	Input/Output	Supported Data Types	Supports Complex Values?
I	Matrix of intensity values	<ul style="list-style-type: none"> <li>• Double-precision floating point</li> <li>• Single-precision floating point</li> <li>• Fixed point</li> <li>• 8-, 16-, 32-bit signed integers</li> <li>• 8-, 16-, 32-bit unsigned integers</li> </ul>	No
Val	Scalar that represents the constant pad value	Same as I port	No
Output	Matrix of intensity values	Same as I port	No

If the data type of the input signal is floating point, the output has the same data type. The data types of the signals input to the I and Val ports must be the same. This block supports a signal represented by a Simulink virtual bus.

Use the **Neighborhood size** parameter to specify the size of the neighborhood over which the block computes the median. You can enter a scalar that represents the number of rows and columns in a square matrix or a vector that represents the number of rows and columns in a rectangular matrix.

Use the **Output size** parameter to specify the size of the output matrix. If you select Same as input port I, the block outputs an intensity image that is the same size as the image input to the I port. If you select Valid, the block only computes the median where the neighborhood fits entirely within the input image, so no padding is required. The dimensions of the output image are

$$\begin{aligned} \text{output rows} &= \text{input rows} - \text{neighborhood rows} + 1 \\ \text{output columns} &= \text{input columns} - \text{neighborhood columns} + 1 \end{aligned}$$

If, for the **Output size** parameter, you choose Same as input port I, the **Padding options** parameter appear on the dialog. Use the

**Padding options** parameter to specify how to pad the boundary of your input matrix. To pad your matrix with a constant value, select Constant. To pad your input matrix by repeating its border values, select Replicate. To pad your input matrix with its mirror image, select Symmetric. To pad your input matrix using a circular repetition of its elements, select Circular. For more information on padding, see the 2-D Pad block reference page.

If, for the **Padding options** parameter, you select Constant, the **Pad value source** parameter appears on the dialog box. If you select Specify via dialog, the **Pad value** parameter appears on the dialog box. Use this parameter to enter the constant value with which to pad your matrix. If, for the **Pad value source** parameter, you select Input port, the Val port appears on the block. Use this port to specify the constant value with which to pad your matrix.

### Fixed-Point Data Types

The information in this section is applicable only when the dimensions of the neighborhood are even.

For fixed-point inputs, you can specify accumulator, product output, and output data types as discussed in “Dialog Box” on page 9-319. Not all these fixed-point parameters are applicable for all types of fixed-point inputs. The following table shows when each kind of data type and scaling is used.

	Output data type	Accumulator data type	Product output data type
Even $M$	X	X	
Odd $M$	X		
Odd $M$ and complex	X	X	X
Even $M$ and complex	X	X	X

The accumulator and output data types and scalings are used for fixed-point signals when  $M$  is even. The result of the sum performed

# Median Filter

---

while calculating the average of the two central rows of the input matrix is stored in the accumulator data type and scaling. The total result of the average is then put into the output data type and scaling.

The accumulator and product output parameters are used for complex fixed-point inputs. The sum of the squares of the real and imaginary parts of such an input are formed before the input elements are sorted. The results of the squares of the real and imaginary parts are placed into the product output data type and scaling. The result of the sum of the squares is placed into the accumulator data type and scaling.

For fixed-point inputs that are both complex and have even  $M$ , the data types are used in all of the ways described. Therefore, in such cases the accumulator type is used in two different ways.



## Dialog Box

The **Main** pane of the Median Filter block dialog appears as follows:

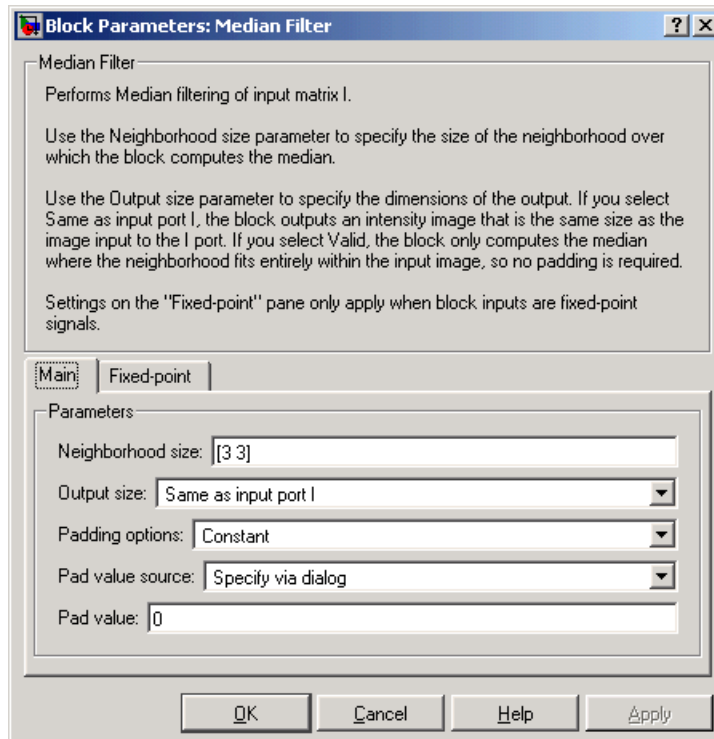

### Neighborhood size

Specify the size of the neighborhood over which the block computes the median. You can enter a scalar that represents the number of rows and columns in a square matrix or a vector that represents the number of rows and columns in a rectangular matrix.

### Output size

This parameter controls the size of the output. If you choose **Same as input port I**, the output has the same dimensions as the input to port I. If you choose **Valid**, output rows = input

# Median Filter

---

rows - neighborhood rows + 1 and output columns = input columns - neighborhood columns + 1.

## **Padding options**

Specify how to pad the boundary of your input matrix. Select **Constant** to pad your matrix with a constant value. Select **Replicate** to pad your input matrix by repeating its border values. Select **Symmetric** to pad your input matrix with its mirror image. Select **Circular** to pad your input matrix using a circular repetition of its elements. This parameter is visible if, for the **Output size** parameter, you select **Same** as input port I.

## **Pad value source**

Use this parameter to specify how to define your constant boundary value. Select **Specify via dialog** to enter your value in the block parameters dialog box. Select **Input port** to specify your constant value using the Val port. This parameter is visible if, for the **Padding options** parameter, you select **Constant**.

## **Pad value**

Enter the constant value with which to pad your matrix. This parameter is visible if, for the **Pad value source** parameter, you select **Specify via dialog**. Tunable.

The **Fixed-point** pane of the Median Filter block dialog appears as follows. The parameters on this dialog are only visible when the dimensions of the neighborhood are even.

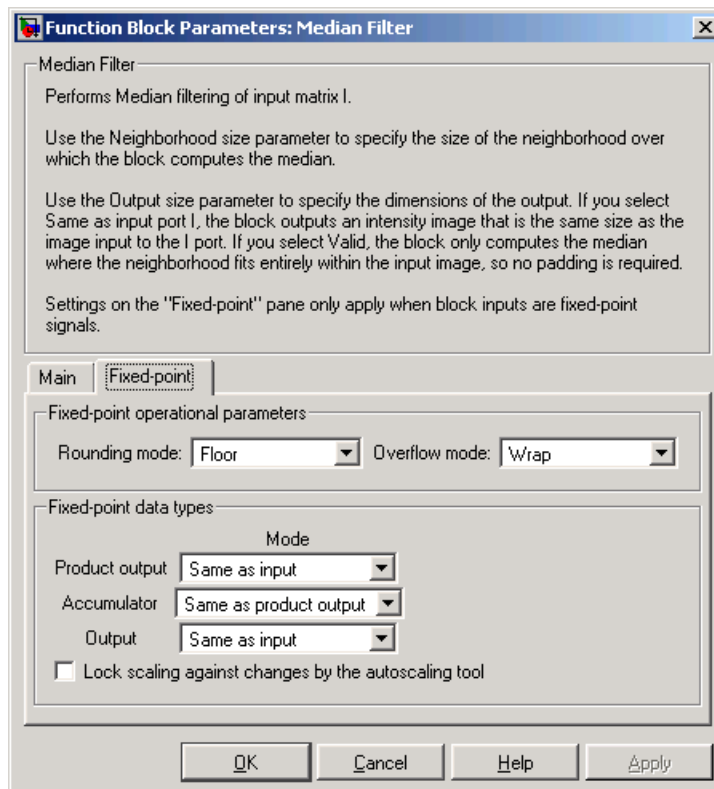

## Rounding mode

Select the rounding mode for fixed-point operations.

## Overflow mode

Select the overflow mode for fixed-point operations.

---

**Note** The product output, accumulator, and output parameters listed below are only used in certain cases. Refer to “Fixed-Point Data Types” on page 9-317 for more information.

---

## Product output

Use this parameter to specify how you would like to designate the product output word and fraction lengths:

- When you select `Same as input`, these characteristics will match those of the input to the block.
- When you select `Binary point scaling`, you can enter the word length and the fraction length of the product output, in bits.
- When you select `Slope and bias scaling`, you can enter the word length, in bits, and the slope of the product output. This block requires power-of-two slope and a bias of zero.

## Accumulator

Use this parameter to specify the accumulator word and fraction lengths resulting from a complex-complex multiplication in the block:

- When you select `Same as product output`, these characteristics will match those of the product output
- When you select `Same as input`, these characteristics will match those of the input to the block.
- When you select `Binary point scaling`, you can enter the word length and the fraction length of the accumulator, in bits.
- When you select `Slope and bias scaling`, you can enter the word length, in bits, and the slope of the accumulator. This block requires power-of-two slope and a bias of zero.

## Output

Choose how you will specify the output word length and fraction length:

- When you select `Same as input`, these characteristics will match those of the input to the block.
- When you select `Binary point scaling`, you can enter the word length and the fraction length of the output, in bits.

- When you select Slope and bias scaling, you can enter the word length, in bits, and the slope of the output. This block requires power-of-two slope and a bias of zero.

### **Lock scaling against changes by the autoscaling tool**

Select this parameter to prevent any fixed-point scaling you specify in this block mask from being overridden by the autoscaling tool in the Fixed-Point Settings interface. For more information about the autoscaling tool, refer to the Fixed-Point Settings Interface section of the Signal Processing Blockset User's Guide.

### **Reference**

Gonzales, Rafael C. and Richard E. Woods. *Digital Image Processing*. 2nd ed. Englewood Cliffs, NJ: Prentice-Hall, 2002.

### **See Also**

2-D Convolution	Video and Image Processing Blockset
2-D FIR Filter	Video and Image Processing Blockset
medfilt2	Image Processing Toolbox

# Opening

**Purpose** Perform morphological opening on binary or intensity images

**Library** Morphological Operations

**Description** The Opening block performs an erosion operation followed by a dilation operation using a predefined neighborhood or structuring element. This block uses flat structuring elements only.

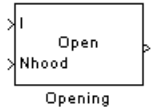

Port	Input/Output	Supported Data Types	Supports Complex Values?
I	Scalar, vector, or matrix of intensity values	<ul style="list-style-type: none"><li>• Double-precision floating point</li><li>• Single-precision floating point</li><li>• Fixed point</li><li>• Boolean</li><li>• 8-, 16-, and 32-bit signed integers</li><li>• 8-, 16-, and 32-bit unsigned integers</li></ul>	No
Nhood	Matrix or vector of ones and zeros that represents the neighborhood values	<ul style="list-style-type: none"><li>• Boolean</li></ul>	No
Output	Scalar, vector, or matrix of intensity values that represents the opened image	Same as I port	No

The output signal has the same data type as the input to the I port. This block supports a signal represented by a Simulink virtual bus.

Use the **Neighborhood or structuring element source** parameter to specify how you want to enter your neighborhood or structuring element values. If you select Specify via dialog, the **Neighborhood**

**or structuring element** parameter appears on the dialog box. If you select **Input port**, the **Nhood** port appears on the block. Use this port to enter your neighborhood values as a matrix or vector of ones and zeros. You can only specify a structuring element using the dialog box.

Use the **Neighborhood or structuring element** parameter to define the region the block moves throughout the image. Specify a neighborhood by entering a matrix or vector of ones and zeros. Specify a structuring element with the `strel` function from the Image Processing Toolbox. If the structuring element is decomposable into smaller elements, the block executes at higher speeds due to the use of a more efficient algorithm.

## Dialog Box

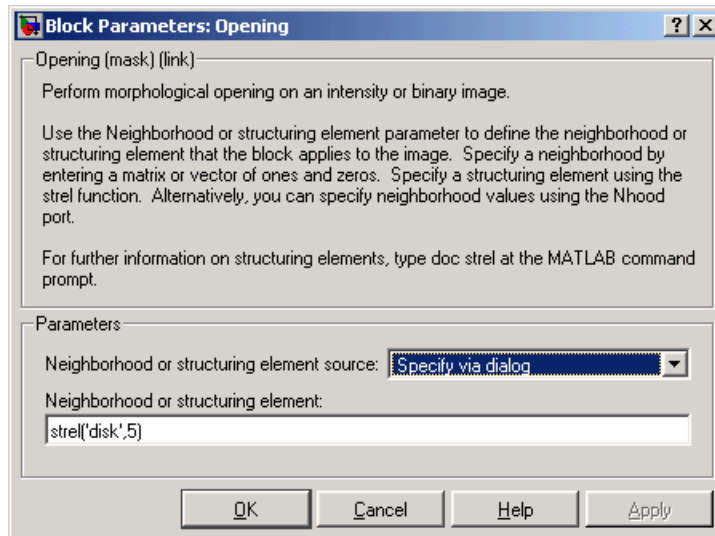

### Neighborhood or structuring element source

Specify how you want to enter your neighborhood or structuring element values. Select **Specify via dialog** to enter the values in the dialog box. Select **Input port** to use the **Nhood** port to specify the neighborhood values. You can only specify a structuring element using the dialog box.

## Neighborhood or structuring element

If you are specifying a neighborhood, this parameter must be a matrix or vector of ones and zeros. If you are specifying a structuring element, use the `strel` function from the Image Processing Toolbox. This parameter is visible if, for the **Neighborhood or structuring element source** parameter, you select Specify via dialog.

## References

Soille, Pierre. *Morphological Image Analysis. 2nd ed.* New York: Springer, 2003.

## See Also

Bottom-hat	Video and Image Processing Blockset
Closing	Video and Image Processing Blockset
Dilation	Video and Image Processing Blockset
Erosion	Video and Image Processing Blockset
Label	Video and Image Processing Blockset
Top-hat	Video and Image Processing Blockset
<code>imopen</code>	Image Processing Toolbox
<code>strel</code>	Image Processing Toolbox



**Purpose** Read uncompressed video frames from AVI file

**Library** Sources

**Description**

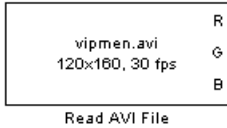

The Read AVI File block reads video frames from an uncompressed AVI file and import them into a Simulink model. You can view the video frames using a To Video Display block or Video Viewer block. This block does not support audio samples or code generation.

The output ports of the Read AVI File block change according the content of the AVI file. If the file contains RGB video frames, the R, G, and B ports appear on the block. If the file contains intensity video frames, the I port appears on the block.

Port	Output	Supported Data Types	Supports Complex Values?
I	Scalar, vector, or matrix of intensity values	<ul style="list-style-type: none"> <li>• Double-precision floating point</li> <li>• Single-precision floating point</li> <li>• 8-, 16- 32-bit signed integers</li> <li>• 8-, 16- 32-bit unsigned integers</li> </ul>	No
R, G, B	Scalar, vector, or matrix that represents one plane of the RGB video stream. Outputs from the R, G, or B ports have same dimensions.	Same as port I	No

Use the **File name** parameter to specify the name of the AVI file from which to read. If the location of this file is on your MATLAB path, enter the filename. If the location of this file is not on your MATLAB path, use the **Browse** button to specify the full path to the file as well as the filename.

# Read AVI File

---

If filename.avi has a colormap associated with it, the AVI file must satisfy the following conditions or the block produces an error:

- The colormap must be empty or have 256 values.
- The data must represent an intensity image.
- The pixel values must be 8-bit.

Select the **Loop** check box if you want to play the file more than once. Then, use the **Number of times to play file** parameter to enter the number of times to play the file. The number you enter must be a positive integer or *inf*, to play the file until you stop the simulation.

Use the **Video output data type** parameter to set the data type of the values output from the block. You can choose double, single, int8, uint8, int16, uint16, int32, uint32, and Inherit from file. If you choose double or single, the block scales the input pixels values and outputs values between 0 and 1. If you choose int8, uint8, int16, uint16, int32, or uint32, the blocks scales the input pixel values and outputs values between the minimum and maximum values supported by the chosen data type. If you choose Inherit from file, the block does not scale the input pixel values.

## Dialog Box

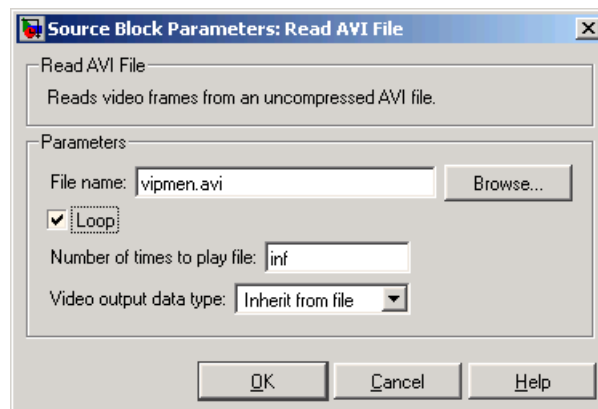

**File name**

Specify the name of the AVI file from which to read.

**Loop**

Select this check box if you want to play the file more than once.

**Number of times to play file**

Enter a positive integer or `inf` to represent the number of times to play the file.

**Video output data type**

Set the data type of the video data output from the block.

**See Also**

Image From Workspace	Video and Image Processing Blockset
Image From File	Video and Image Processing Blockset
From Multimedia File	Video and Image Processing Blockset
To Multimedia File	Video and Image Processing Blockset
To Video Display	Video and Image Processing Blockset
Video From Workspace	Video and Image Processing Blockset
Video Viewer	Video and Image Processing Blockset
Write AVI File	Video and Image Processing Blockset

# Read Binary File

**Purpose** Read binary video data from files

**Library** Sources

**Description** The Read Binary File block reads video data from a binary file and imports it into a Simulink model.



Port	Output	Supported Data Types	Supports Complex Values?
Output	Scalar, vector, or matrix of integer values	<ul style="list-style-type: none"><li>8-, 16- 32-bit unsigned integers</li></ul>	No

All output ports have the same data type.

Use the **File name** parameter to specify the name of the binary file from which to read. If the location of this file is on your MATLAB path, enter the filename. If the location of this file is not on your MATLAB path, use the **Browse** button to specify the full path to the file as well as the filename.

Select the **Loop** check box if you want to play the file more than once. Then, use the **Number of times to play file** parameter to enter the number of times to play the file. The number you enter must be a positive integer or `inf`, to play the file until you stop the simulation.

Use the **Video format** parameter to specify the format of the binary video data. Your choices are Four character codes or Custom. See “Four Character Code Video Formats” on page 9-331 or “Custom Video Formats” on page 9-331 for more details.

Use the **Line ordering** parameter to determine how the block fills the output matrix. If you select Top line first, the block first fills the first row of the output matrix with the contents of the binary file. It fills

the other rows in increasing order. If you select **Bottom line first**, the block first fills the last row of the output matrix. It fills the other rows in decreasing order.

Use the **Sample time** parameter to set the sample period of the output signal.

## Four Character Code Video Formats

Four Character Codes (FOURCC) are used to identify video formats. For more information about these codes, see <http://www.fourcc.org>.

Use the **Four character code** parameter to identify the binary file format. Then use the **Rows** and **Cols** parameters to define the size of the output matrix. These dimensions should match the matrix dimensions of the data inside the file.

## Custom Video Formats

If your binary file contains data that is not in FOURCC format, you can configure the Read Binary File block to understand a custom format.

Use the **Bit stream format** parameter to specify whether your data is planar or packed. If your data is packed, use the **Rows** and **Cols** parameters to define the size of the output matrix.

Use the **Number of output components** parameter to specify the number of components in the binary file. This number corresponds to the number of block output ports.

Use the **Component**, **Bits**, **Rows**, and **Cols** parameters to specify the component name, bit size, and size of the output matrices, respectively. The block uses the **Component** parameter to label the output ports.

Use the **Component order in binary file** parameter to specify how the components are arranged within the file.

Select the **Interlaced video** check box if the binary file contains interlaced video data.

# Read Binary File

---

## Dialog Box

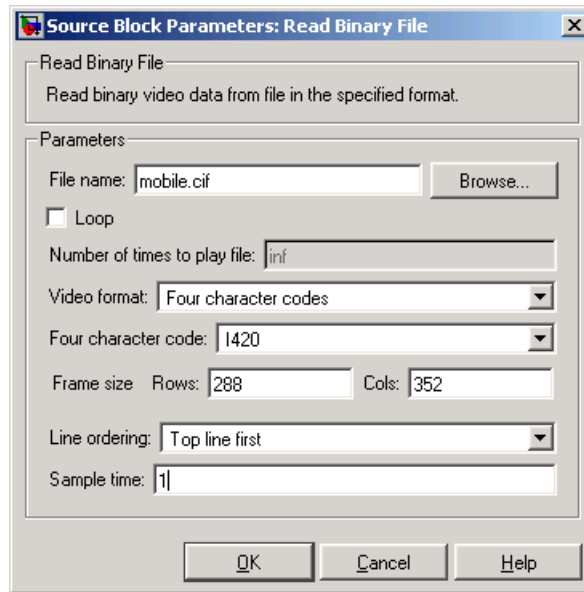

### File name

Specify the name of the binary file.

### Loop

Select this check box if you want to play the file more than once.

### Number of times to play file

Enter a positive integer or `inf` to represent the number of times to play the file.

### Video format

Specify the format of the binary video data. Your choices are Four character codes or Custom.

### Four character code

From the list, select the binary file format.

### Frame size: Rows, Cols

Define the size of the output matrix. These dimensions should match the matrix dimensions of the data inside the file.

## Line ordering

Specify how the block fills the output matrix. If you select **Top line first**, the block first fills the first row of the output matrix with the contents of the binary file. If you select **Bottom line first**, the block first fills the last row of the output matrix.

## Sample time

Enter the sample period of the output signal.

The screenshot shows a dialog box titled "Source Block Parameters: Read Binary File". The dialog has a "Parameters" section with the following fields and options:

- File name:  - Loop
- Number of times to play file:
- Video format:  (dropdown)
- Bit stream format:  (dropdown)
- Number of output components:  (dropdown)
- Component 1:  Bits:  Rows:  Cols:
- Component 2:  Bits:  Rows:  Cols:
- Component 3:  Bits:  Rows:  Cols:
- Component order in binary file:
- Interlaced video
- Line ordering:  (dropdown)
- Sample time:

Buttons at the bottom:

## Bit stream format

Specify whether your data is planar or packed.

## Frame size: Rows, Cols

Define the size of the output matrix. This parameter is visible if, for the **Bit stream format** parameter, you select **Packed**.

# Read Binary File

---

## **Number of output components**

Specify the number of components in the binary file. This number corresponds to the number of block output ports.

## **Component, Bits, Rows, Cols**

Specify the component name, bit size, and size of the output matrices, respectively.

## **Component order in binary file**

Specify how the components are arranged within the binary file.

## **Interlaced video**

Select this check box if the binary file contains interlaced video data.

## **See Also**

From Multimedia File	Video and Image Processing Blockset
Read AVI File	Video and Image Processing Blockset



**Purpose** Enlarge or shrink size of images

**Library** Geometric Transformations

**Description** The Resize block enlarges or shrinks an image by resizing the image along one dimension (row or column). Then it resizes the image along the other dimension (column or row).



Port	Input/Output	Supported Data Types	Supports Complex Values?
Input	Matrix of intensity values	<ul style="list-style-type: none"> <li>• Double-precision floating point</li> <li>• Single-precision floating point</li> <li>• 8-bit unsigned integers</li> </ul>	No
Output	Matrix of intensity values	Same as Input port	No

If the data type of the input signal is floating point, the output has the same data type. This block supports a signal represented by a Simulink virtual bus.

Use the **Specify** parameter to designate the parameters you want to use to resize your image. Your choices are Output size as a percentage of input size, Number of output columns and preserve aspect ratio, Number of output rows and preserve aspect ratio, Number of output rows and columns.

If, for the **Specify** parameter, you select Output size as a percentage of input size, the **Resize factor in %** parameter appears on the dialog. Enter a scalar percentage value that is applied to both rows and columns. You must enter a scalar that is greater than zero.

For a  $0 < \text{resize factor} < 100$ , the block shrinks the image. For  $\text{resize factor} = 100$ , the block does not change the image. For  $\text{resize factor} > 100$ , the block enlarges the image. The dimensions of the output matrix

# Resize

---

depend on the **Resize factor in %** parameter and are given by the following equations:

```
number_output_rows =  
round(number_input_rows*resize_factor/100);
```

```
number_output_cols =  
round(number_input_cols*resize_factor/100);
```

Alternatively, you can enter a two-element vector, where the first element is the percentage by which to resize the rows and the second element is the percentage by which to resize the columns.

If, for the **Specify** parameter, you select Number of output columns and preserve aspect ratio, the **Number of output columns** parameter appears on the dialog. Enter a scalar that represents the number of columns you want the output image to have. The block calculates the number of output rows so that the output image has the same aspect ratio as the input image.

If, for the **Specify** parameter, you select Number of output rows and preserve aspect ratio, the **Number of output rows** parameter appears on the dialog. Enter a scalar that represents the number of rows you want the output image to have. The block calculates the number of output columns so that the output image has the same aspect ratio as the input image.

If, for the **Specify** parameter, you select Number of output rows and columns, the **Number of output rows and columns** parameter appears on the dialog. Enter a two-element vector, where the first element is the number of rows in the output image and the second element is the number of columns. In this case, the aspect ratio of the image can change.

Use the **Interpolation method** parameter to specify which interpolation method the block uses to resize the image. If you select Nearest neighbor, the block uses 1 nearby pixel to interpolate the pixel value. This selection is the most computationally efficient, but it is the least accurate. If you select Bilinear, the block uses 2 nearby pixels to interpolate the pixel value. If you select Bicubic or Lanczos2,

the block uses 4 nearby pixels to interpolate the pixel value. If you select Lanczos3, the block uses 6 surrounding pixels to interpolate the pixel value.

Shrinking an image can introduce high frequency components into the image and aliasing might occur. If you select the **Perform antialiasing when resize factor is between 0 and 1** check box, the block performs low pass filtering on the input image before shrinking it.

### Fixed-Point Data Types

The following diagram shows the data types used within the Resize block for fixed-point signals.

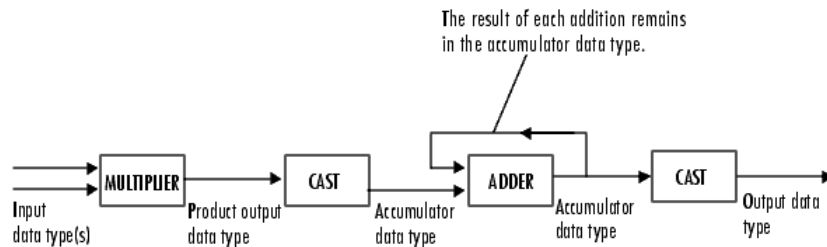

You can set the interpolation weights table, product output, accumulator, and output data types in the block mask.

# Resize

## Dialog Box

The **Main** pane of the Resize block dialog appears as follows:

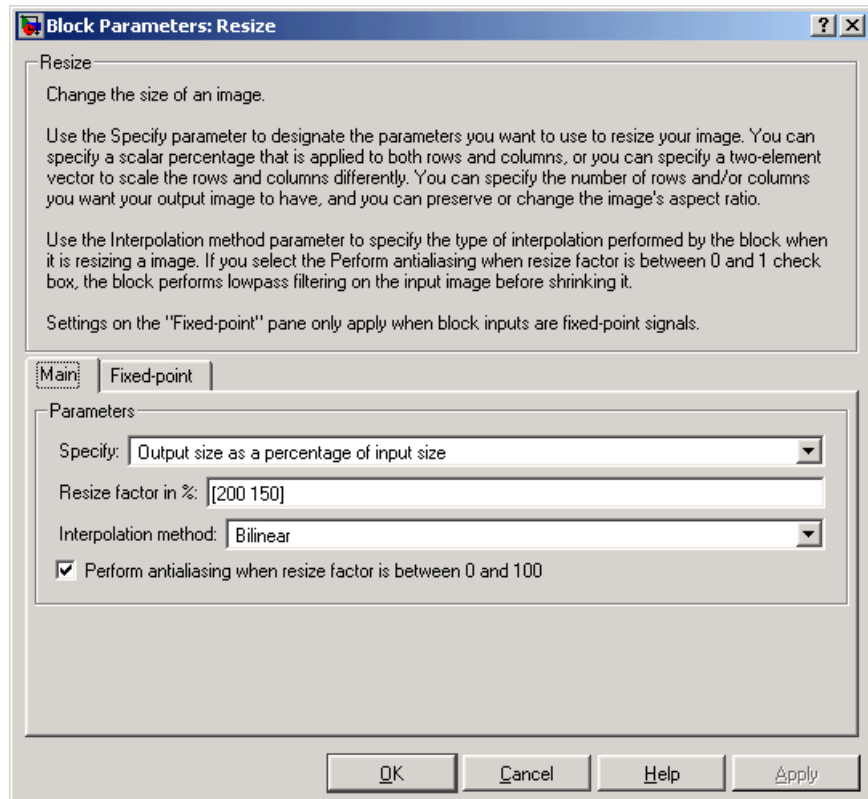

### Specify

Specify which aspect(s) of the image you want to resize. Your choices are Output size as a percentage of input size, Number of output columns and preserve aspect ratio, Number of output rows and preserve aspect ratio, Number of output rows and columns.

**Resize factor in %**

Enter a scalar percentage value that is applied to both rows and columns or a two-element vector, where the first element is the percentage by which to resize the rows and the second element is the percentage by which to resize the columns. This parameter is visible if, for the **Specify** parameter, you select Output size as a percentage of input size.

**Number of output columns**

Enter a scalar that represents the number of columns you want the output image to have. This parameter is visible if, for the **Specify** parameter, you select Number of output columns and preserve aspect ratio.

**Number of output rows**

Enter a scalar that represents the number of rows you want the output image to have. This parameter is visible if, for the **Specify** parameter, you select Number of output rows and preserve aspect ratio.

**Number of output rows and columns**

Enter a two-element vector, where the first element is the number of rows in the output image and the second element is the number of columns. This parameter is visible if, for the **Specify** parameter, you select Number of output rows and columns.

**Interpolation method**

Determine which interpolation method the block uses to resize the image. If you select Nearest neighbor, the block uses 1 nearby pixel to interpolate the pixel value. If you select Bilinear, the block uses 2 nearby pixels to interpolate the pixel value. If you select Bicubic or Lanczos2, the block uses 4 nearby pixels to interpolate the pixel value. If you select Lanczos3, the block uses 6 surrounding pixels to interpolate the pixel value.

**Perform antialiasing when resize factor is between 0 and 1**

If you select this check box, the block performs low pass filtering on the input image before shrinking it to prevent aliasing.

# Resize

The **Fixed-point** pane of the Resize block dialog appears as follows:

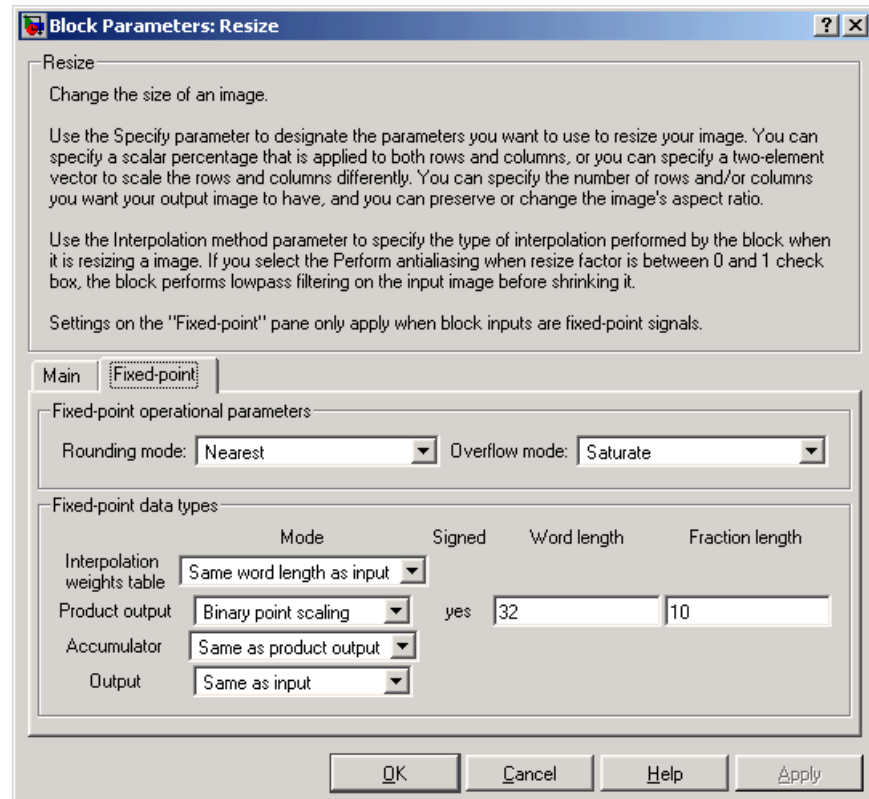

## Rounding mode

Select the rounding mode for fixed-point operations.

## Overflow mode

Select the overflow mode for fixed-point operations.

## Interpolation weights table

Choose how you will specify the word length of the values of the interpolation weights table. The fraction length of the

interpolation weights table values is always equal to the word length minus one:

- When you select `Same as input`, the word length of the interpolation weights table values will match that of the input to the block.
- When you select `Binary point scaling`, you can enter the word length of the interpolation weights table values, in bits.
- When you select `Slope and bias scaling`, you can enter the word length of the interpolation weights table values, in bits.

## Product output



As depicted above, the output of the multiplier is placed into the product output data type and scaling. Use this parameter to specify how you would like to designate this product output word and fraction lengths.

- When you select `Same as input`, these characteristics will match those of the input to the block.
- When you select `Binary point scaling`, you can enter the word length and the fraction length of the product output, in bits.
- When you select `Slope and bias scaling`, you can enter the word length, in bits, and the slope of the product output. The bias of all signals in the Signal Processing Blockset is zero.

## Accumulator

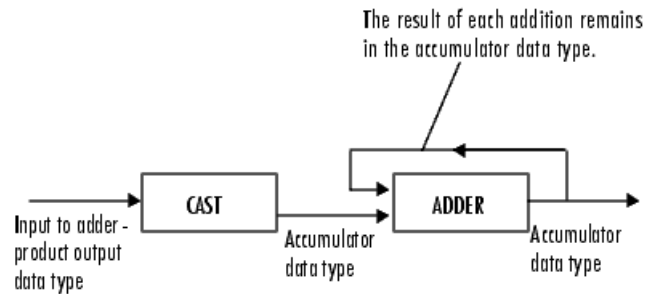

As depicted above, inputs to the accumulator are cast to the accumulator data type. The output of the adder remains in the accumulator data type as each element of the input is added to it. Use this parameter to specify how you would like to designate this accumulator word and fraction lengths.

- When you select **Same as product output**, these characteristics will match those of the product output.
- When you select **Same as input**, these characteristics will match those of the input to the block.
- When you select **Binary point scaling**, you can enter the word length and the fraction length of the accumulator, in bits.
- When you select **Slope and bias scaling**, you can enter the word length, in bits, and the slope of the accumulator. The bias of all signals in the Signal Processing Blockset is zero.

## Output

Choose how you will specify the word length and fraction length of the output of the block:

- When you select **Same as input**, these characteristics will match those of the input to the block.



- When you select Binary point scaling, you can enter the word length and the fraction length of the output, in bits.
- When you select Slope and bias scaling, you can enter the word length, in bits, and the slope of the output. The bias of all signals in the Video and Image Processing Blockset is zero.

## References

Ward, Joseph and David R. Cok. "Resampling Algorithms for Image Resizing and Rotation", Proc. SPIE Digital Image Processing Applications, vol. 1075, pp. 260-269, 1989.

Wolberg, George. *Digital Image Warping*. Washington: IEEE Computer Society Press, 1990.

## See Also

Rotate	Video and Image Processing Blockset
Shear	Video and Image Processing Blockset
Translate	Video and Image Processing Blockset
imresize	Image Processing Toolbox

# Rotate

**Purpose** Rotate image by specified angle

**Library** Geometric Transformations

**Description** Use the Rotate block to rotate an image by an angle specified in radians.

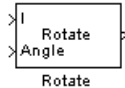

Port	Input/Output	Supported Data Types	Supports Complex Values?
I	Matrix of intensity values or a matrix that represents one plane of the RGB video stream	<ul style="list-style-type: none"><li>• Double-precision floating point</li><li>• Single-precision floating point</li><li>• Fixed point</li><li>• 8-, 16-, 32-bit signed integers</li><li>• 8-, 16-, 32-bit unsigned integers</li></ul>	No
Angle	Rotation angle	Same as I port	No
Output	Rotated matrix	Same as I port	No

If the data type of the input signal is floating point, the output signal is the same data type as the input signal. This block supports a signal represented by a Simulink virtual bus.

Use the **Output size** parameter to specify the size of the rotated matrix. If you select Expanded to fit rotated input image, the block outputs a matrix that contains all the rotated image values and zeros for the values outside the rotated image. If you select Same as input image, the block outputs a matrix that contains the middle part of the rotated image and zeros for the values outside the rotated image. As a result, the edges of the rotated image might be cropped.

Use the **Rotation angle source** parameter to specify how you want to enter your rotation angle. If you select Specify via dialog, the **Angle (radians)** parameter appears on the dialog box. Use it to enter a real, scalar value for your rotation angle. If you select Input port, the Angle port appears on the block. The block uses the input to this port at each time step as your rotation angle. The input to the Angle port must be the same data type as the input to the I port.

If, for the **Output size** parameter, you select Expanded to fit rotated input image, and, for **Rotation angle source** parameter, you select Input port, the **Maximum angle (enter pi radians to accommodate all positive and negative angles)**, **Display rotated image in**, **Sine value computation method**, and **Interpolation method** parameters appear on the dialog box. If, for the **Output size** parameter, you select Same as input image, and, for **Rotation angle source** parameter, you select Input port, the **Maximum angle (enter pi radians to accommodate all positive and negative angles)**, **Sine value computation method**, and **Interpolation method** parameters appears on the dialog box.

For the **Maximum angle (enter pi radians to accommodate all positive and negative angles)** parameter, enter a scalar value,

$$0 < \max angle \leq \pi$$

radians, that represents the maximum angle by which you want to rotate the input image. The block determines which angle,

$0 \leq angle \leq \max angle$ , requires the largest output matrix and sets the dimensions of the output port accordingly. To accommodate all angles, enter

$\pi$   
radians.

Use the **Display rotated image in** parameter to determine how the image is rotated in the display window. If you select Center, the image is rotated about its center point. If you select Top-left corner, the block rotates the image so that two corners of the image are always in contact with the top and left side of the Matrix Viewer window.

# Rotate

---

Use the **Sine value computation method** parameter to specify how much memory the Rotate block requires. If you select `Trigonometric function`, the block computes sine and cosine values it needs to calculate the rotation of your image during the simulation. If you select `Table lookup`, the block computes and stores the trigonometric values it needs to calculate the rotation of your image before the simulation starts. In this case, the block requires extra memory.

Use the **Interpolation method** parameter to specify which interpolation method the block uses to rotate the image. If you select `Nearest neighbor`, the block uses the value of the nearest pixel for the new pixel value. If you select `Bilinear`, the new pixel value is the weighted average of the two nearest pixel values. If you select `Bicubic`, the new pixel value is the weighted average of the four nearest pixel values.

The number of pixels the block considers affects the complexity of the computation. Therefore, the nearest-neighbor interpolation is the most computationally efficient. However, because the accuracy of the method is proportional to the number of pixels considered, the bicubic method is the most accurate. For more information, see “Interpolation Overview” on page 4-2.

## Fixed-Point Data Types

The following diagram shows the data types used within the Rotate block for bilinear interpolation of fixed-point signals.

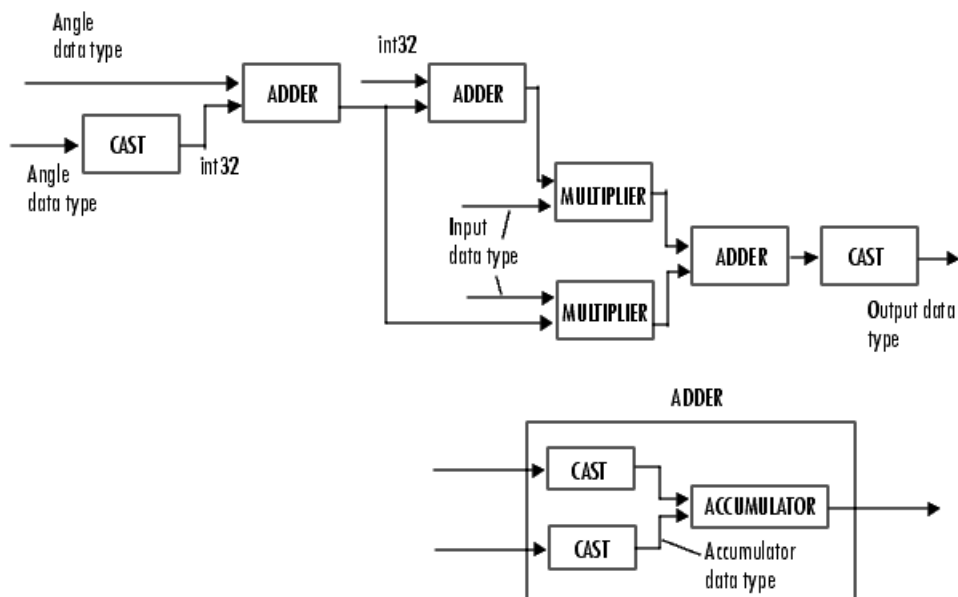

You can set the angle values, product output, accumulator, and output data types in the block mask.

The Rotate block requires additional data types. The Sine table value has the same word length as the angle data type and a fraction length that is equal to its word length minus one. The following diagram shows how these data types are used inside the block.

# Rotate

---

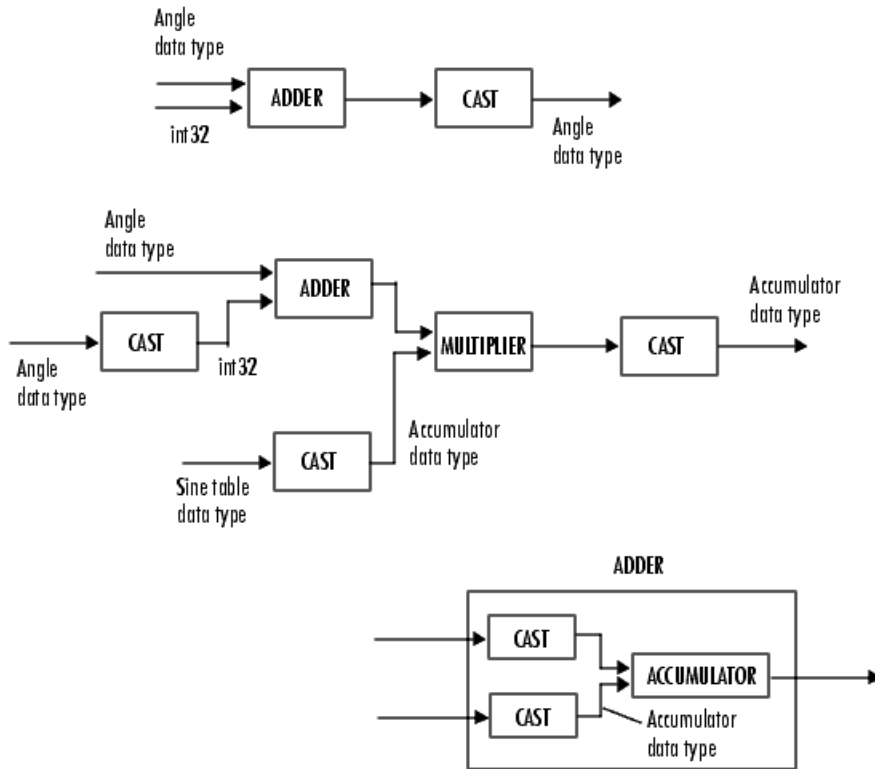

---

**Note** If overflow occurs, the rotated image might appear distorted.

---

## Dialog Box

The **Main** pane of the Rotate block dialog appears as follows:

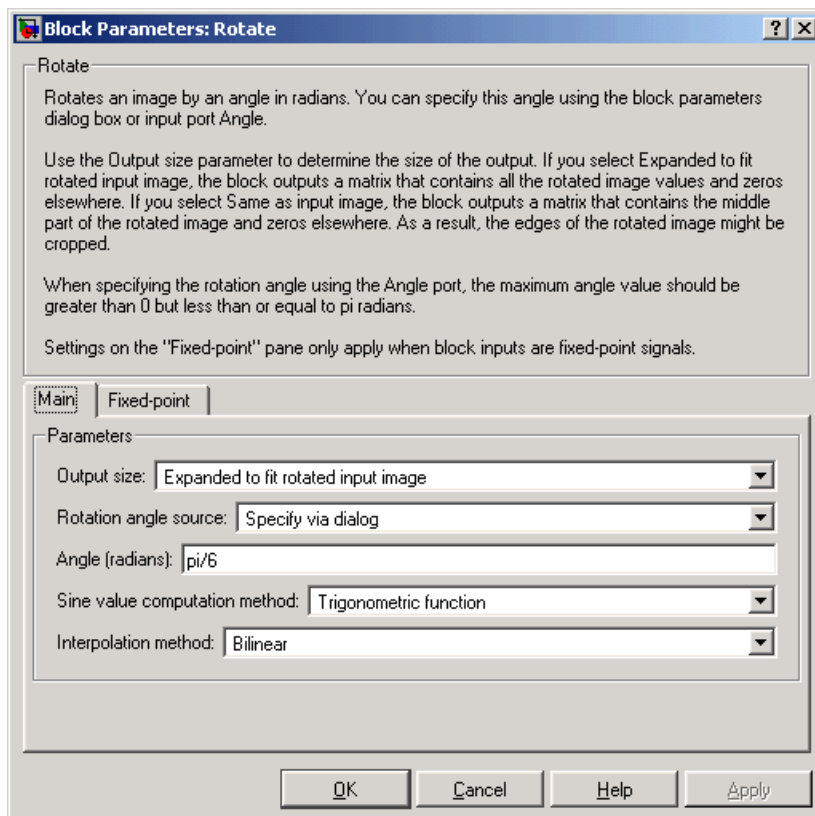

### Output size

If you select **Expanded to fit rotated input image**, the block outputs a matrix that contains all the rotated image values and zeros for the values outside the image. If you select **Same as input image**, the block outputs a matrix that contains the middle part of the rotated image and zeros for the values outside the image.

## **Rotation angle source**

Specify how you want to enter your rotation angle. If you select Specify via dialog, the **Angle (radians)** parameter appears on the dialog box. If you select Input port, the Angle port appears on the block. The block uses the input to this port at each time step as your rotation angle.

## **Angle (radians)**

Enter a real-valued scalar for your rotation angle. This parameter is visible if, for the **Rotation angle source** parameter, you select Specify via dialog.

## **Maximum angle (enter pi radians to accommodate all positive and negative angles)**

Enter the maximum angle by which you want to rotate the input image. This parameter is visible if, for the **Output size** parameter, you select Expanded to fit rotated input image, and, for the **Rotation angle source** parameter, you select Input port.

## **Display rotated image in**

Specify how the image is rotated. If you select Center, the image is rotated about its center point. If you select Top-left corner, the block rotates the image so that two corners of the image are always in contact with the top and left side of the Matrix Viewer window. This parameter is visible if, for the **Output size** parameter, you select Expanded to fit rotated input image, and, for the **Rotation angle source** parameter, you select Input port.

## **Sine value computation method**

If you select Trigonometric function, the block computes sine and cosine values it needs to calculate the rotation of your image during the simulation. If you select Table lookup, the block computes and stores the trigonometric values it needs to calculate the rotation of your image before the simulation starts. In this case, the block requires extra memory. This parameter is visible if, for the **Rotation angle source** parameter, you select Input port.



## Interpolation method

Specify which interpolation method the block uses to rotate the image. If you select **Nearest neighbor**, the block uses the value of one nearby pixel for the new pixel value. If you select **Bilinear**, the new pixel value is the weighted average of the two nearest pixel values. If you select **Bicubic**, the new pixel value is the weighted average of the four nearest pixel values.

The **Fixed-point** pane of the Rotate block dialog appears as follows:

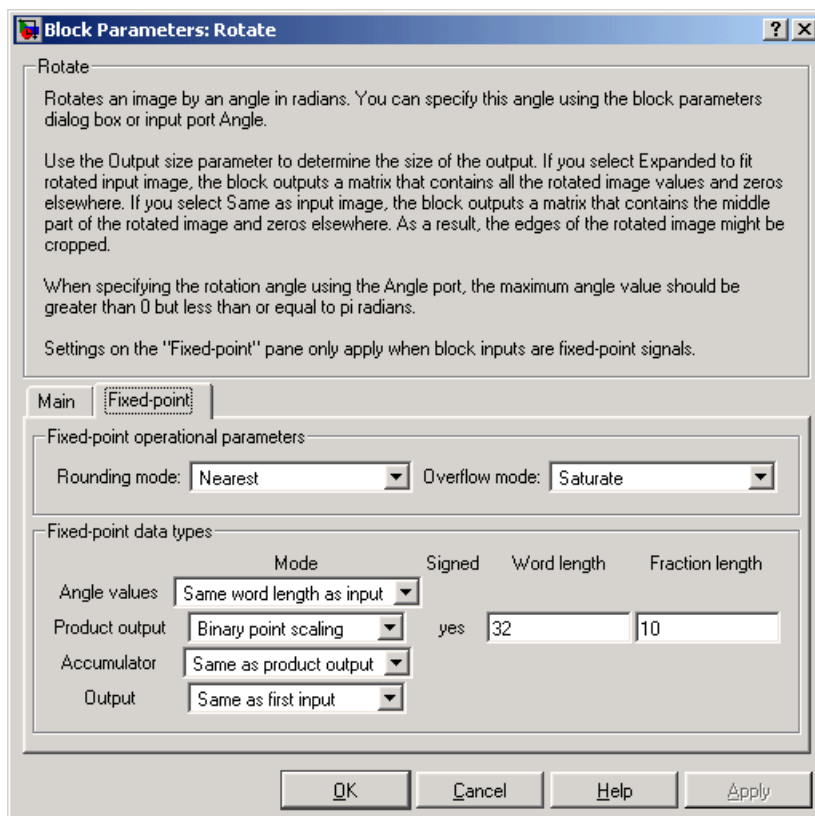

# Rotate

---

## **Rounding mode**

Select the rounding mode for fixed-point operations.

## **Overflow mode**

Select the overflow mode for fixed-point operations.

## **Angle values**

Choose how you will specify the word length and the fraction length of the angle values.

- When you select **Same word length as input**, the word length of the angle values will match that of the input to the block. In this mode, the fraction length of the angle values is automatically set to the binary-point only scaling that provides you with the best precision possible given the value and word length of the angle values.
- When you select **Specify word length**, you can enter the word length of the angle values, in bits. The block automatically sets the fractional length to give you the best precision.
- When you select **Binary point scaling**, you can enter the word length and the fraction length of the angle values, in bits.
- When you select **Slope and bias scaling**, you can enter the word length, in bits, and the slope of the angle values. The bias of all signals in the Video and Image Processing Blockset is zero.

This parameter is only visible if, for the **Rotation angle source** parameter, you select **Specify via dialog**.

## **Product output**



As depicted above, the output of the multiplier is placed into the product output data type and scaling. Use this parameter to specify how you would like to designate this product output word and fraction lengths.

- When you select `Same` as first input, these characteristics will match those of the input to the block.
- When you select `Binary point scaling`, you can enter the word length and the fraction length of the product output, in bits.
- When you select `Slope and bias scaling`, you can enter the word length, in bits, and the slope of the product output. The bias of all signals in the Video and Image Processing Blockset is zero.

## Accumulator

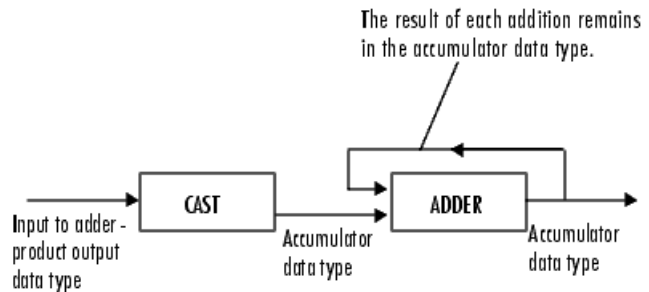

As depicted above, inputs to the accumulator are cast to the accumulator data type. The output of the adder remains in the accumulator data type as each element of the input is added to it. Use this parameter to specify how you would like to designate this accumulator word and fraction lengths.

- When you select `Same` as product output, these characteristics will match those of the product output.

# Rotate

---

- When you select `Same as first input`, these characteristics will match those of the first input to the block.
- When you select `Binary point scaling`, you can enter the word length and the fraction length of the accumulator, in bits.
- When you select `Slope and bias scaling`, you can enter the word length, in bits, and the slope of the accumulator. The bias of all signals in the Video and Image Processing Blockset is zero.

## Output

Choose how you will specify the word length and fraction length of the output of the block:

- When you select `Same as first input`, these characteristics will match those of the first input to the block.
- When you select `Binary point scaling`, you can enter the word length and the fraction length of the output, in bits.
- When you select `Slope and bias scaling`, you can enter the word length, in bits, and the slope of the output. The bias of all signals in the Video and Image Processing Blockset is zero.

## Reference

Wolberg, George. *Digital Image Warping*. Washington: IEEE Computer Society Press, 1990.

## See Also

Resize	Video and Image Processing Blockset
Translate	Video and Image Processing Blockset
Shear	Video and Image Processing Blockset
imrotate	Image Processing Toolbox

**Purpose** Perform two-dimensional sum of absolute differences (SAD)

**Library** Analysis & Enhancement

**Description** The SAD block finds the similarity between two input images by performing the sum of absolute differences. The greater the similarity between the two matrices, the smaller the SAD values that result. Assume that input matrix I has dimensions (Mi, Ni) and the input matrix Template has dimensions (Mt, Nt). The equation for the two-dimensional discrete SAD is

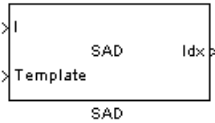

$$C(j,k) = \sum_{m=0}^{(Mt-1)} \sum_{n=0}^{(Nt-1)} abs(I(m+j,n+k) - T(m,n))$$

where

$$0 \leq j < Mi - Mt + 1$$

and

$$0 \leq k < Ni - Nt + 1$$

Port	Input/Output	Supported Data Types	Supports Complex Values?
I	Matrix of intensity values	<ul style="list-style-type: none"> <li>• Double-precision floating point</li> <li>• Single-precision floating point</li> <li>• Fixed point</li> <li>• 8-, 16-, and 32-bit signed integers</li> <li>• 8-, 16-, and 32-bit unsigned integers</li> </ul>	No
Template	Matrix of intensity values	Same as I port	No
ROI	Four-element vector that	<ul style="list-style-type: none"> <li>• Double-precision floating point</li> </ul>	No

# SAD

Port	Input/Output	Supported Data Types	Supports Complex Values?
	defines the ROI	<ul style="list-style-type: none"> <li>• Single-precision floating point</li> <li>• 8-, 16-, and 32-bit signed integers</li> <li>• 8-, 16-, and 32-bit unsigned integers</li> </ul>	
Val	Matrix of SAD values	<ul style="list-style-type: none"> <li>• Double-precision floating point</li> <li>• Single-precision floating point</li> <li>• Fixed point</li> <li>• 8-, 16-, and 32-bit signed integers</li> <li>• 8-, 16-, and 32-bit unsigned integers</li> </ul>	No
Idx	Scalar that represents the zero-based index location of the minimum SAD value	<ul style="list-style-type: none"> <li>• 32-bit signed integers</li> </ul>	No
NVals	N-by-N matrix of SAD values centered around the minimum SAD value	Same as Val port	No
NValid	Boolean 0 or 1 that represents whether or not the block went beyond the dimensions of the SAD value matrix to construct an N-by-N matrix around the minimum SAD value	<ul style="list-style-type: none"> <li>• Boolean</li> </ul>	No

The data type of the two input signals must be the same. The output signal is the same data type as the input signals.

The dimensions of the output at the Val port are determined by the sizes of the inputs at ports I and Template. If the input at port I has

dimensions ( $M_i$ ,  $N_i$ ) and the input at the Template port dimensions ( $M_t$ ,  $N_t$ ), then the output has dimensions ( $M_i - M_t + 1$ ,  $N_i - N_t + 1$ ).

Use the **Output** parameter to determine the output of the block. If you select SAD values, the block outputs the SAD values at the Val port. If you select Minimum SAD value index, the block outputs the zero-based index location of the minimum SAD value at the Idx port.

If, for the **Output** parameter, you select Minimum SAD value index, the **Search method used** parameter appears on the dialog box. If you select Exhaustive, the block searches the two input matrices for the minimum difference pixel-by-pixel. This process is described by the equation above and is computationally expensive.

If, for the **Search method used** parameter, you select Three-step, the block searches the two input matrices for the minimum difference using a steadily decreasing step size. The block begins with a step size approximately equal to half the maximum search range. In each step, the block compares the central point of the search region to eight search points located on the boundaries of the region and moves the central point to the search point whose values is the closest to that of the central point. The block then reduces the step size by half, and begins the process again. This option is less computationally expensive, though it might not find the optimal solution.

If, for the **Output** parameter, you select Minimum SAD value index, the **Use ROI for input I** check box appears on the dialog box. If you select this check box, the ROI port appears on the block. Use this port to define a region of interest (ROI) in the input matrix, I, over which you want to compute the SAD. The input to this port must be a 4-element vector, [row column height width]. The first two elements define the upper left corner of the ROI, and the second two elements define the height and width of the ROI.

Use the **Invalid ROI** parameter to specify the block's behavior if you enter a ROI that is outside the bounds of the input matrix, I. The options are

- Ignore – Proceed with the computation and do not issue an alert. The output is not valid.
- Warn – Display a warning message in the MATLAB Command Window, and continue the simulation. The output is not valid.
- Error – Display an error dialog box and terminate the simulation.

If, for the **Output** parameter, you select Minimum SAD value index, the **Output NxN matrix of SAD values around minimum** check box appears on the dialog box. If you select this check box, the NVals and NValid ports appear on the block. The block outputs an N-by-N matrix of SAD values centered around the minimum SAD value at the NVals port. Use the **Size (N) of square matrix** parameter to determine the size of this matrix. The value you enter must be a real-valued, odd integer that is greater than or equal to 1.

If the block must go beyond the dimensions of the SAD value matrix to construct an N-by-N matrix around the minimum SAD value, the values outside the SAD value matrix are zero. In this case, the block outputs a Boolean 0 at the NValid port. If the block does not go beyond the dimensions of the SAD value matrix to construct an N-by-N matrix around the minimum SAD value, the block outputs a Boolean 1 at the NValid port.

### Fixed-Point Data Types

The following diagram shows the data types used within the SAD block for fixed-point signals.



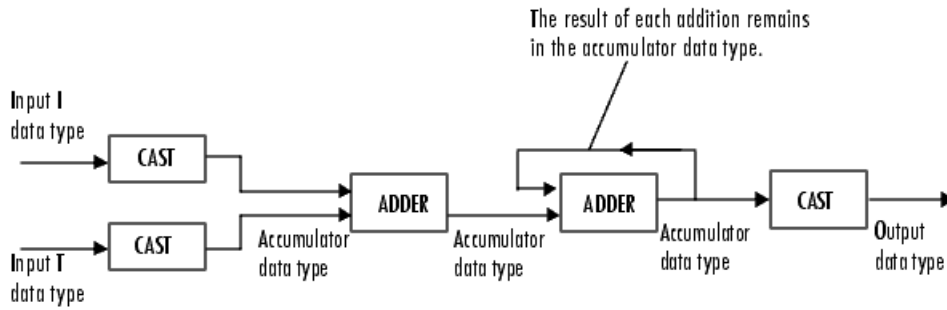

You can set the accumulator, and output data types in the block mask as discussed below.

## Dialog Box

The **Main** pane of the SAD block dialog box appears as follows:

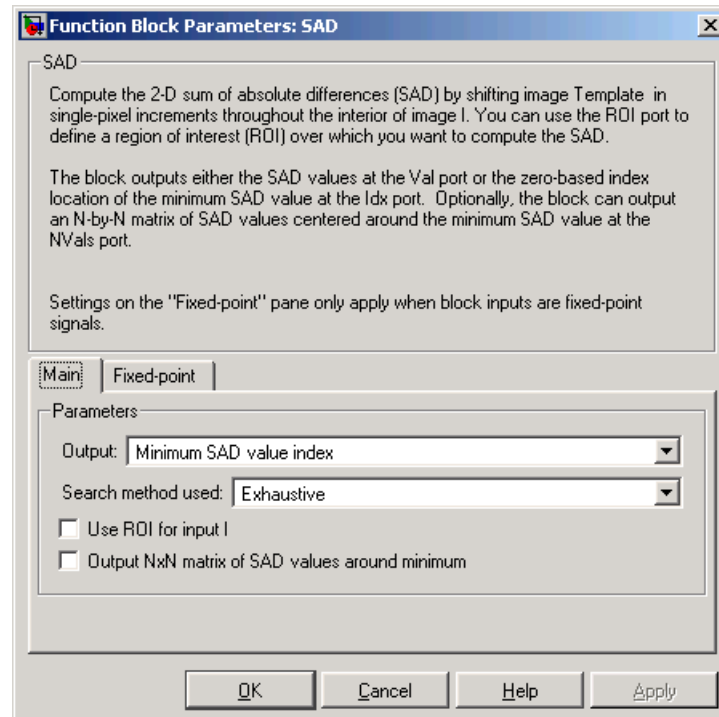

### Output

Specify the output of the block. Your choices are SAD values or Minimum SAD value index. If you select Minimum SAD value index, the block outputs the zero-based index location of the minimum SAD value.

### Search method used

Specify how the block searches for the minimum difference between the two input matrices. If you select Exhaustive, the block searches for the minimum difference pixel-by-pixel. If you select Three-step, the block searches for the minimum difference

using a steadily decreasing step size. This parameter is visible if, for the **Output** parameter, you select Minimum SAD value index.

**Use ROI for input I**

If you select this check box, the ROI port appears on the block. Use this port to define a region of interest (ROI) in the input matrix, I, over which you want to compute the SAD. This parameter is visible if, for the **Output** parameter, you select Minimum SAD value index.

**Invalid ROI**

Specify the block's behavior if you enter a ROI that is outside the bounds of the input matrix, I. The options are Ignore, Warn, or Error.

**Output NxN matrix of SAD values around minimum**

If you select this check box, the NVals and NValid ports appear on the block. The block outputs an N-by-N matrix of SAD values centered around the minimum SAD value at the NVals port. If the block must go beyond the dimensions of the SAD value matrix to construct the N-by-N output matrix, the block outputs a Boolean 0 at the NValid port. Otherwise, the block outputs a Boolean 1 at the NValid port. This parameter is visible if, for the **Output** parameter, you select Minimum SAD value index.

**Size (N) of square matrix**

Enter an odd number that determines the size of the N-by-N matrix of SAD values. This parameter is visible if you select the **Output NxN matrix of SAD values around minimum** check box.

The **Fixed-point** pane of the SAD block dialog box appears as follows:

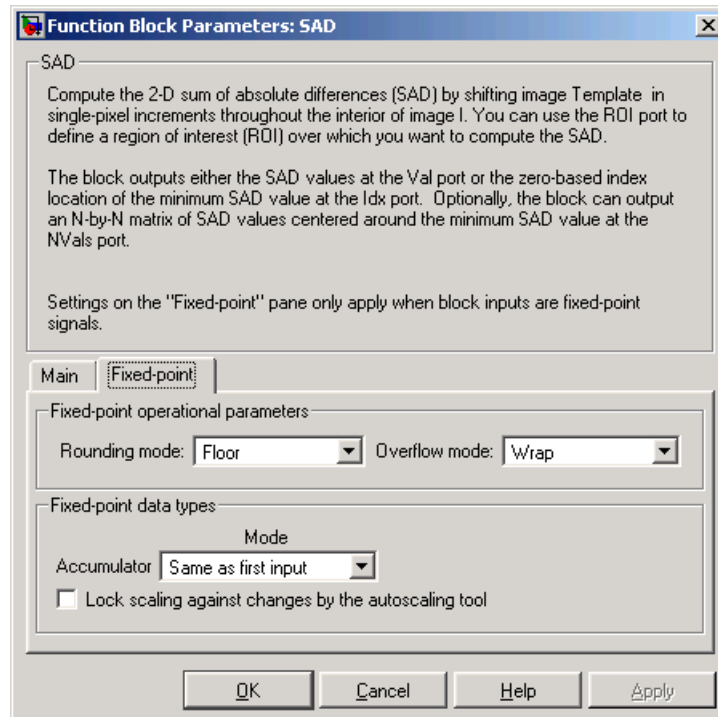

## **Rounding mode**

Select the rounding mode for fixed-point operations.

## **Overflow mode**

Select the overflow mode for fixed-point operations.

## Accumulator

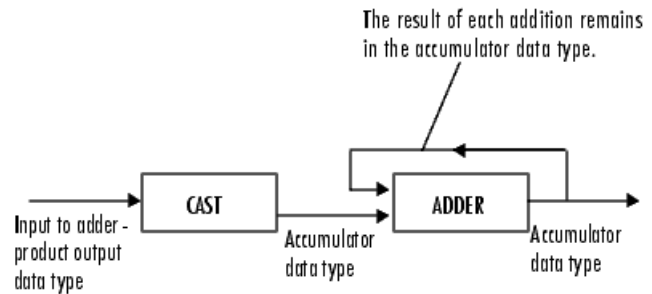

As depicted above, inputs to the accumulator are cast to the accumulator data type. The output of the adder remains in the accumulator data type as each element of the input is added to it. Use this parameter to specify how you would like to designate this accumulator word and fraction lengths.

- When you select `Same` as first input, these characteristics will match those of the input to the block.
- When you select `Binary point scaling`, you can enter the word length and the fraction length of the accumulator, in bits.
- When you select `Slope and bias scaling`, you can enter the word length, in bits, and the slope of the accumulator. The bias of all signals in the Signal Processing Blockset is zero.

## Output

Choose how you will specify the word length and fraction length of the output of the block:

- When you select `Same` as first input, these characteristics will match those of the first input to the block.
- When you select `Binary point scaling`, you can enter the word length and the fraction length of the output, in bits.

- When you select Slope and bias scaling, you can enter the word length, in bits, and the slope of the output. The bias of all signals in the Signal Processing Blockset is zero.

This parameter is not visible if, for the **Output** parameter you select Minimum SAD value index, and you clear the **Output NxN matrix of SAD values around minimum** check box.

### **Lock scaling against changes by the autoscaling tool**

Select this parameter to prevent any fixed-point scaling you specify in this block mask from being overridden by the autoscaling tool in the Fixed-Point Settings interface. For more information about the autoscaling tool, refer to the Fixed-Point Settings Interface section of the Signal Processing Blockset User's Guide.

## **References**

Koga, T., et al. *Motion-compensated interframe coding for video conferencing*. In Nat. Telecommun. Conf., Nov. 1981, G5.3.1-5, New Orleans, LA.

Wang, Yao, Jorn Ostermann, Ya-Qin Zhang. *Video Processing and Communications*. Upper Saddle River, NJ: Prentice Hall, 2002.

**Purpose** Shift each row or column of an image by a linearly varying offset

**Library** Geometric Transformations

**Description** The Shear block shifts the rows or columns of an image by a gradually increasing distance left or right or up or down.

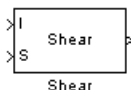

Port	Input/Output	Supported Data Types	Supports Complex Values?
I	Matrix of intensity values or matrix that represents one plane of the RGB video stream	<ul style="list-style-type: none"> <li>• Double-precision floating point</li> <li>• Single-precision floating point</li> <li>• Fixed point</li> </ul>	No
S	Two-element vector that represents the number of pixels by which you want to shift your first and last rows or columns	Same as I port	No
Output	Matrix of shifted values	Same as I port	No

If the data type of the input to the I port is floating point, the input to the S port of this block must be the same data type. Also, the block output is the same data type. This block supports a signal represented by a Simulink virtual bus.

Use the **Shear direction** parameter to specify whether you want to shift the rows or columns. If you select `Horizontal`, the first row has an offset equal to the first element of the **Row/column shear values [first last]** vector. The following rows have an offset that linearly increases up to the value you enter for the last element of the **Row/column shear values [first last]** vector. If you select `Vertical`, the first column has an offset equal to the first element of the

**Row/column shear values [first last]** vector. The following columns have an offset that linearly increases up to the value you enter for the last element of the **Row/column shear values [first last]** vector.

Use the **Output size after shear** parameter to specify the size of the sheared image. If you select `Full`, the block outputs a matrix that contains the entire sheared image and zeros for the values outside the image. If you select `Same as input image`, the block outputs a matrix that is the same size as the input image and contains the top left portion of the sheared image and zeros for the values outside the image.

Use the **Shear values source** parameter to specify how you want to enter your shear parameters. If you select `Specify via dialog`, the **Row/column shear values [first last]** parameter appears on the dialog box. Use this parameter to enter a two-element vector that represents the number of pixels by which you want to shift your first and last rows or columns. For example, if for the **Shear direction** parameter you select `Horizontal` and, for the **Row/column shear values [first last]** parameter, you enter `[50 150]`, the block moves the top left corner 50 pixels to the right and the bottom left corner of the input image 150 pixels to the right. If you want to move either corner to the left, enter negative values. If for the **Shear direction** parameter you select `Vertical` and, for the **Row/column shear values [first last]** parameter, you enter `[-10 50]`, the block moves the top left corner 10 pixels up and the top right corner 50 pixels down. If you want to move either corner down, enter positive values.

Use the **Interpolation method** parameter to specify which interpolation method the block uses to shear the image. If you select `Nearest neighbor`, the block uses the value of the nearest pixel for the new pixel value. If you select `Bilinear`, the new pixel value is the weighted average of the two nearest pixel values. If you select `Bicubic`, the new pixel value is the weighted average of the four nearest pixel values.

The number of pixels the block considers affects the complexity of the computation. Therefore, the nearest-neighbor interpolation is the most computationally efficient. However, because the accuracy of the method is proportional to the number of pixels considered, the bicubic method is



the most accurate. For more information, see “Interpolation Overview” on page 4-2.

If, for the **Shear values source** parameter, you select Input port, the S port appears on the block. At each time step, the input to the S port must be a two-element vector that represents the number of pixels by which you want to shift your first and last rows or columns.

If, for the **Output size after shear** parameter, you select Full, and for the **Shear values source** parameter, you select Input port, the **Maximum shear value** parameter appears on the dialog box. Use this parameter to enter a real, scalar value that represents the maximum number of pixels by which you want to shear your image. The block uses this parameter to determine the size of the output matrix. If any input to the S port is greater than the absolute value of the **Maximum shear value** parameter, the block saturates to the maximum value.

### **Fixed-Point Data Types**

The following diagram shows the data types used within the Shear block for bilinear interpolation of fixed-point signals.

# Shear

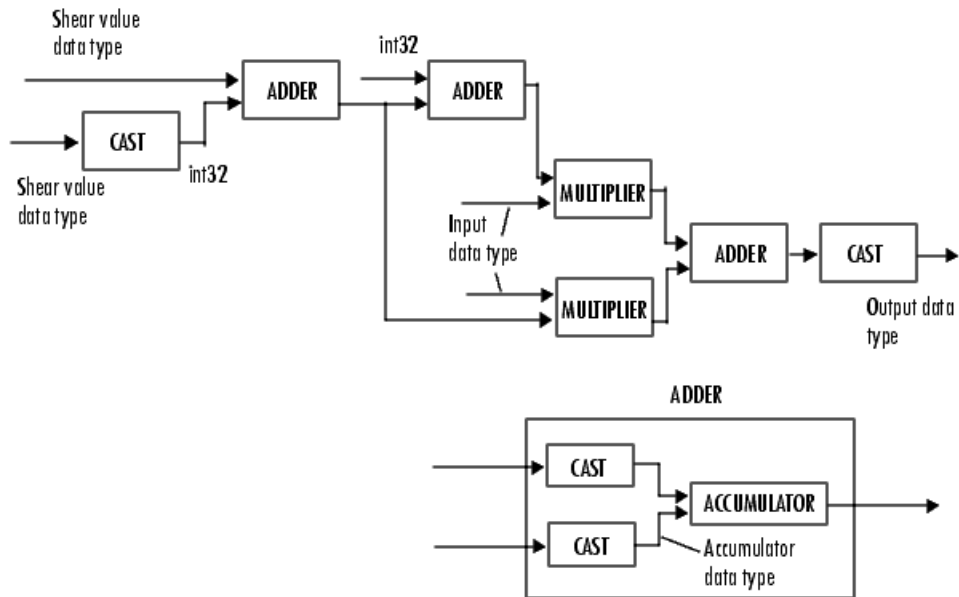

You can set the product output, accumulator, and output data types in the block mask.

## Dialog Box

The **Main** pane of the Shear block dialog box appears as follows:

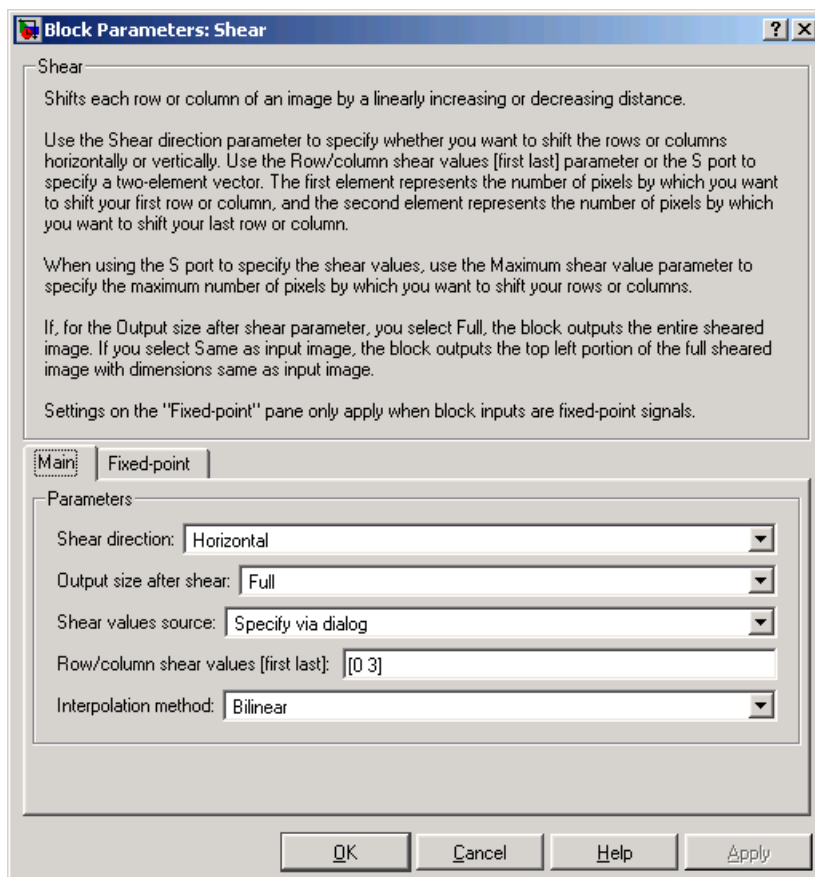

### Shear direction

Specify whether you want to shift the rows or columns of the input image. Select **Horizontal** to linearly increase the offset of the rows. Select **Vertical** to steadily increase the offset of the columns.

## **Output size after shear**

Specify the size of the sheared image. If you select `Full`, the block outputs a matrix that contains the sheared image values and zeros for the values outside the image. If you select `Same` as input image, the block outputs a matrix that is the same size as the input image and contains a portion of the sheared image and zeros for the values outside the image.

## **Shear values source**

Specify how you want to enter your shear parameters. If you select `Specify via dialog`, the **Row/column shear values [first last]** parameter appears on the dialog box. If you select `Input port`, port `S` appears on the block. The block uses the input to this port at each time step as your shear value.

## **Row/column shear values [first last]**

Enter a two-element vector that represents the number of pixels by which you want to shift your first and last rows or columns. This parameter is visible if, for the **Shear values source** parameter, you select `Specify via dialog`.

## **Interpolation method**

Specify which interpolation method the block uses to shear the image. If you select `Nearest neighbor`, the block uses the value of one nearby pixel for the new pixel value. If you select `Bilinear`, the new pixel value is the weighted average of the two nearest pixel values. If you select `Bicubic`, the new pixel value is the weighted average of the four nearest pixel values.

## **Maximum shear value**

Enter a real, scalar value that represents the maximum number of pixels by which you want to shear your image. This parameter is visible if, for the **Output size after shear** parameter, you select `Full` and, for the **Shear values source** parameter, you select `Input port`.

The **Fixed-point** pane of the Shear block dialog box appears as follows:

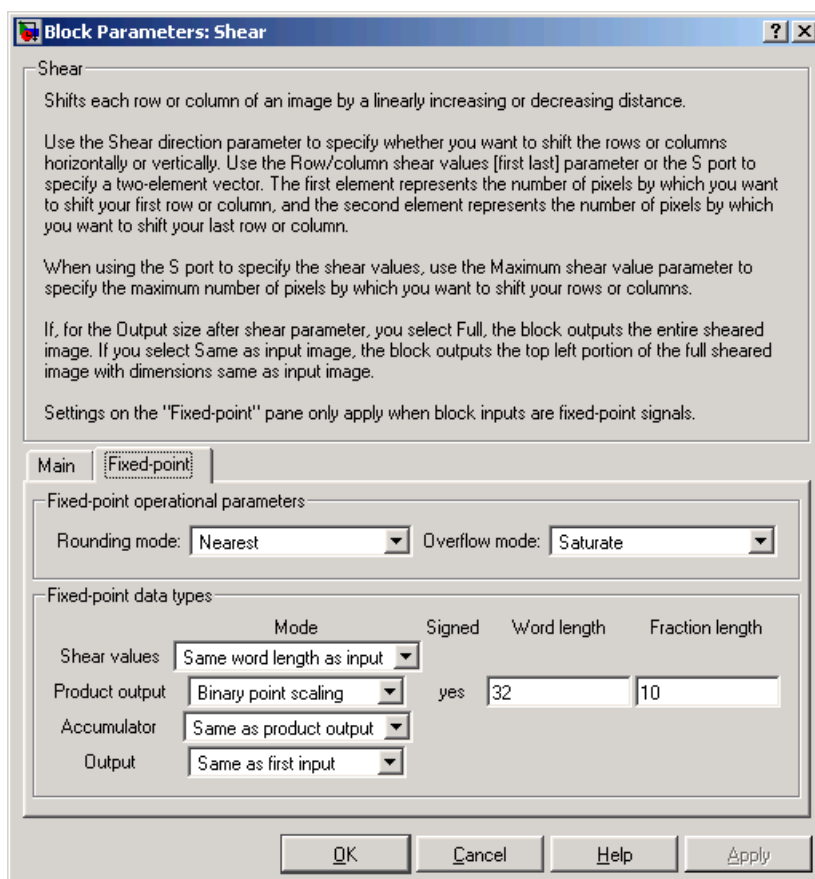

### Rounding mode

Select the rounding mode for fixed-point operations.

### Overflow mode

Select the overflow mode for fixed-point operations.

### Shear values

Choose how you will specify the word length and the fraction length of the shear values.

# Shear

---

- When you select **Same word length** as input, the word length of the shear values will match that of the input to the block. In this mode, the fraction length of the shear values is automatically set to the binary-point only scaling that provides you with the best precision possible given the value and word length of the shear values.
- When you select **Specify word length**, you can enter the word length of the shear values, in bits. The block automatically sets the fractional length to give you the best precision.
- When you select **Binary point scaling**, you can enter the word length and the fraction length of the shear values, in bits.
- When you select **Slope and bias scaling**, you can enter the word length, in bits, and the slope of the shear values. The bias of all signals in the Video and Image Processing Blockset is zero.

This parameter is visible if, for the **Shear values source** parameter, you select **Specify** via dialog.

## Product output



As depicted above, the output of the multiplier is placed into the product output data type and scaling. Use this parameter to specify how you would like to designate this product output word and fraction lengths.

- When you select **Same as first input**, these characteristics will match those of the first input to the block at the I port.

- When you select Binary point scaling, you can enter the word length and the fraction length of the product output, in bits.
- When you select Slope and bias scaling, you can enter the word length, in bits, and the slope of the product output. The bias of all signals in the Video and Image Processing Blockset is zero.

### Accumulator

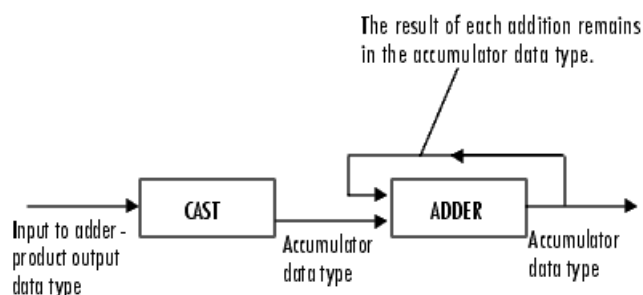

As depicted above, inputs to the accumulator are cast to the accumulator data type. The output of the adder remains in the accumulator data type as each element of the input is added to it. Use this parameter to specify how you would like to designate this accumulator word and fraction lengths.

- When you select Same as product output, these characteristics will match those of the product output.
- When you select Same as first input, these characteristics will match those of the first input to the block at the I port.
- When you select Binary point scaling, you can enter the word length and the fraction length of the accumulator, in bits.

- When you select `Slope and bias scaling`, you can enter the word length, in bits, and the slope of the accumulator. The bias of all signals in the Video and Image Processing Blockset is zero.

## Output

Choose how you will specify the word length and fraction length of the output of the block:

- When you select `Same as first input`, these characteristics will match those of the first input to the block at the I port.
- When you select `Binary point scaling`, you can enter the word length and the fraction length of the output, in bits.
- When you select `Slope and bias scaling`, you can enter the word length, in bits, and the slope of the output. The bias of all signals in the Signal Processing Blockset is zero.

## Reference

Wolberg, George. *Digital Image Warping*. Washington: IEEE Computer Society Press, 1990.

## See Also

Resize	Video and Image Processing Blockset
Rotate	Video and Image Processing Blockset
Translate	Video and Image Processing Blockset



<b>Purpose</b>	Write video frames and/or audio samples to multimedia file
<b>Library</b>	Sinks
<b>Description</b>	The To Multimedia File block is a Signal Processing Blockset block. For more information, see the To Multimedia File block reference page in the Signal Processing Blockset documentation.

# To Video Display

**Purpose** Send video data to video output device, video camera, video monitor, or window on your computer screen

**Library** Sinks

**Description** The To Video Display block sends video data to a DirectX supported video output device or video camera. Alternatively, you can send the video data to a separate monitor or view the data in a window on your own computer screen.

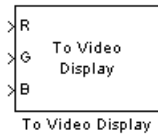

---

**Note** This block supports code generation and is only supported on 32-bit Windows platforms. This block performs best on platforms with DirectX Version 9.0 or later and Windows Media Version 9.0 or later.

---

Port	Input	Supported Data Types	Supports Complex Values?
I	Matrix of intensity values	<ul style="list-style-type: none"><li>• Double-precision floating point</li><li>• Single-precision floating point</li><li>• Boolean</li><li>• 8-, 16, and 32-bit signed integers</li><li>• 8-, 16, and 32-bit unsigned integers</li></ul>	No
R, G, B	Matrix that represents one plane of the RGB video stream. Inputs to the R, G, or B ports must have the same dimensions and data type.	Same as I port	No

For the block to display video data properly, double- and single-precision floating-point pixel values must be between 0 and 1. For any other data

type, the pixel values must be between the minimum and maximum values supported by their data type.

Use the **Input image type** parameter to specify the type of image or video stream you want to view. If you select RGB, the R, G, and B ports appear on the block. Use this option for RGB images and video. If you select Intensity, the I port appears on the block. Use this option for binary and intensity images and video.

Use the **Video output device** parameter to specify where you want the video stream to be sent. If you select On-screen video monitor, your video stream is displayed in the **To Video Display** window when you run your model. This window closes automatically when the simulation stops. The other options available in this parameter list are the DirectX supported video output devices installed on your system.

Select the **Full-screen** check box to display your video stream in a full-screen window. To return to other applications, hold down the **Alt** key and press **Tab**. If you have multiple To Video Display blocks in one model and you set the **Video output device** parameter to On-screen video monitor, we recommend selecting the **Full-screen** check box for only one of the blocks.

Select the **Remember video window size** check box if you want the block to save changes you make to the size of the video window.

# To Video Display

---

## Dialog Box

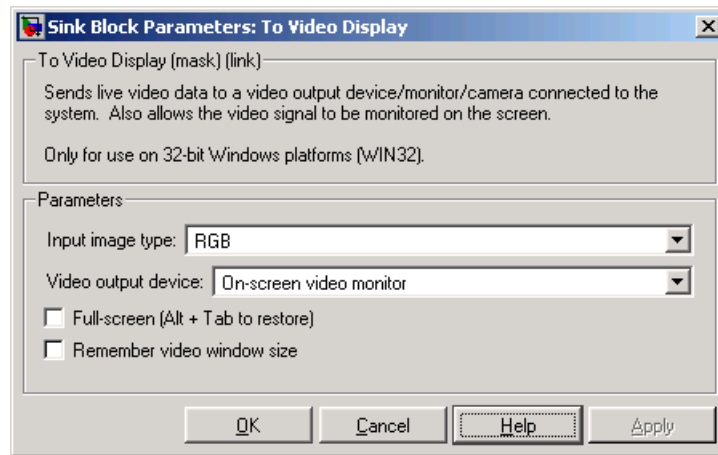

### Input image type

Specify the type of image or video stream you want to view. Your choices are RGB or Intensity.

### Video output device

Choose the video output device you want to use to display your video data.

### Full-screen

Select this check box to display your video stream in a full screen window. This parameter is visible if, for the **Video output device** parameter, you select On-screen video monitor.

### Remember video window size

Select this check box if you want the block to save changes you make to the size of the video window.

## See Also

Frame Rate Display

Video and Image Processing Blockset

From Multimedia File

Video and Image Processing Blockset

To Multimedia File

Video and Image Processing Blockset

Video To Workspace

Video Viewer

Video and Image Processing Blockset

Video and Image Processing Blockset

# Top-hat

**Purpose** Perform top-hat filtering on intensity or binary images

**Library** Morphological Operations

**Description** The Top-hat block performs top-hat filtering on an intensity or binary image using a predefined neighborhood or structuring element. Top-hat filtering is the equivalent of subtracting the result of performing a morphological opening operation on the input image from the input image itself. This block uses flat structuring elements only.



Port	Input/Output	Supported Data Types	Supports Complex Values?
I	Scalar, vector, or matrix of intensity values or scalar, vector, or matrix that represents one plane of the input RGB video stream	<ul style="list-style-type: none"><li>• Double-precision floating point</li><li>• Single-precision floating point</li><li>• Fixed point</li><li>• Boolean</li><li>• 8-, 16-, and 32-bit signed integers</li><li>• 8-, 16-, and 32-bit unsigned integers</li></ul>	No
Nhood	Matrix or vector of ones and zeros that represents the neighborhood values	<ul style="list-style-type: none"><li>• Boolean</li></ul>	No
Output	Scalar, vector, or matrix that represents the filtered image	Same as I port	No

If your input image is a binary image, for the **Input image type** parameter, select Binary. If your input image is an intensity image, select Intensity.

Use the **Neighborhood or structuring element source** parameter to specify how you want to enter your neighborhood or structuring

element values. If you select Specify via dialog, the **Neighborhood or structuring element** parameter appears on the dialog box. If you select Input port, the Nhood port appears on the block. Use this port to enter your neighborhood values as a matrix or vector of ones and zeros. Choose your structuring element so that it matches the shapes you want to remove from your image. You can only specify a it using the dialog box.

Use the **Neighborhood or structuring element** parameter to define the region the block moves throughout the image. Specify a neighborhood by entering a matrix or vector of ones and zeros. Specify a structuring element with the `strel` function from the Image Processing Toolbox. If the structuring element is decomposable into smaller elements, the block executes at higher speeds due to the use of a more efficient algorithm.

## Dialog Box

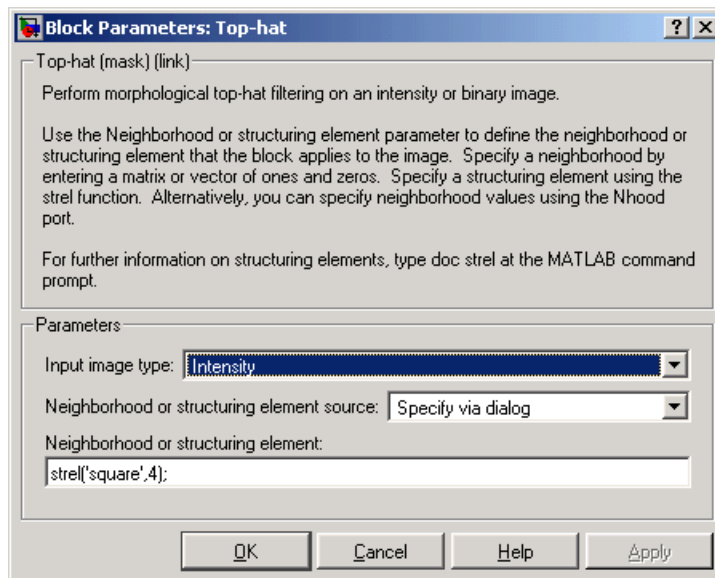

## **Input image type**

If your input image is a binary image, select Binary. If your input image is an intensity image, select Intensity.

## **Neighborhood or structuring element source**

Specify how you want to enter your neighborhood or structuring element values. Select Specify via dialog to enter the values in the dialog box. Select Input port to use the Nhood port to specify the neighborhood values. You can only specify a structuring element using the dialog box.

## **Neighborhood or structuring element**

If you are specifying a neighborhood, this parameter must be a matrix or vector of ones and zeros. If you are specifying a structuring element, use the strel function from the Image Processing Toolbox. This parameter is visible if, for the **Neighborhood or structuring element source** parameter, you select Specify via dialog.

## **See Also**

Bottom-hat	Video and Image Processing Blockset
Closing	Video and Image Processing Blockset
Dilation	Video and Image Processing Blockset
Erosion	Video and Image Processing Blockset
Label	Video and Image Processing Blockset
Opening	Video and Image Processing Blockset
imtophat	Image Processing Toolbox
strel	Image Processing Toolbox



**Purpose** Translate image in two-dimensional plane using displacement vector

**Library** Geometric Transformations

**Description** Use the Translate block to move an image in a two-dimensional plane using a displacement vector, a 2-element vector that represents the number of pixels by which you want to translate your image. The block outputs the image produced as the result of the translation.



Port	Input/Output	Supported Data Types	Supports Complex Values?
I/Input	Scalar, vector, or matrix of intensity values	<ul style="list-style-type: none"> <li>• Double-precision floating point</li> <li>• Single-precision floating point</li> <li>• Fixed point</li> <li>• 8-, 16-, 32-bit signed integers</li> <li>• 8-, 16-, 32-bit unsigned integers</li> </ul>	No
Offset	Scalar, vector, or matrix of intensity values	Same as I port.	No
Output	Scalar, vector, or matrix of intensity values	Same as I port.	No

The input to the Offset port must be the same data type as the input to the I port. The output is the same data type as the input to the I port. This block supports signals represented by Simulink virtual buses.

Use the **Output size after translation** parameter to specify the size of the translated image. If you select Full, the block outputs a matrix that contains the entire translated image and zeros for the values outside the image. If you select Same as input image, the block outputs a

matrix that is the same size as the input image and contains a portion of the translated image and zeros for the values outside the image.

Use the **Translation values source** parameter to specify how you want to enter your displacement vector. If you select Specify via dialog, the **Offset** parameter appears on the dialog box. Use it to enter your displacement vector, a 2-element vector,  $[r \ c]$ , of real, integer values that represent the number of pixels by which you want to translate your image. The  $r$  value represents how many pixels up or down you want to shift your image. The  $c$  value represents how many pixels left or right you want to shift your image. The axis origin is the top left corner of your image. For example, if you enter  $[2.5 \ 3.2]$ , the block moves the image 2.5 pixels downward and 3.2 pixels to the right of its original location. When the displacement vector contains fractional values, the block uses interpolation to compute the output.

Use the **Interpolation method** parameter to specify which interpolation method the block uses to translate the image. If you translate your image in either the horizontal or vertical direction and you select Nearest neighbor, the block uses the value of the nearest pixel for the new pixel value. If you translate your image in either the horizontal or vertical direction and you select Bilinear, the new pixel value is the weighted average of the two nearest pixel values. If you translate your image in either the horizontal or vertical direction and you select Bicubic, the new pixel value is the weighted average of the four nearest pixel values.

The number of pixels the block considers affects the complexity of the computation. Therefore, the nearest-neighbor interpolation is the most computationally efficient. However, because the accuracy of the method is roughly proportional to the number of pixels considered, the bicubic method is the most accurate. For more information, see “Interpolation Overview” on page 4-2.

If, for the **Output size after translation** parameter, you select Full, and for the **Translation values source** parameter, you select Input port, the **Maximum offset** parameter appears on the dialog box. Use the **Maximum offset** parameter to enter a 2-element vector of real, scalar values that represent the maximum number of pixels by which

you want to translate your image. The block uses this parameter to determine the size of the output matrix. If the input to the Offset port is greater than the **Maximum offset** parameter values, the block saturates to the maximum values.

If, for the **Translation values source** parameter, you select Input port, the Offset port appears on the block. At each time step, the input to the Offset port must be a vector of real, scalar values that represent the number of pixels by which you want to translate your image.

## Fixed-Point Data Types

The following diagram shows the data types used within the Translate block for bilinear interpolation of fixed-point signals.

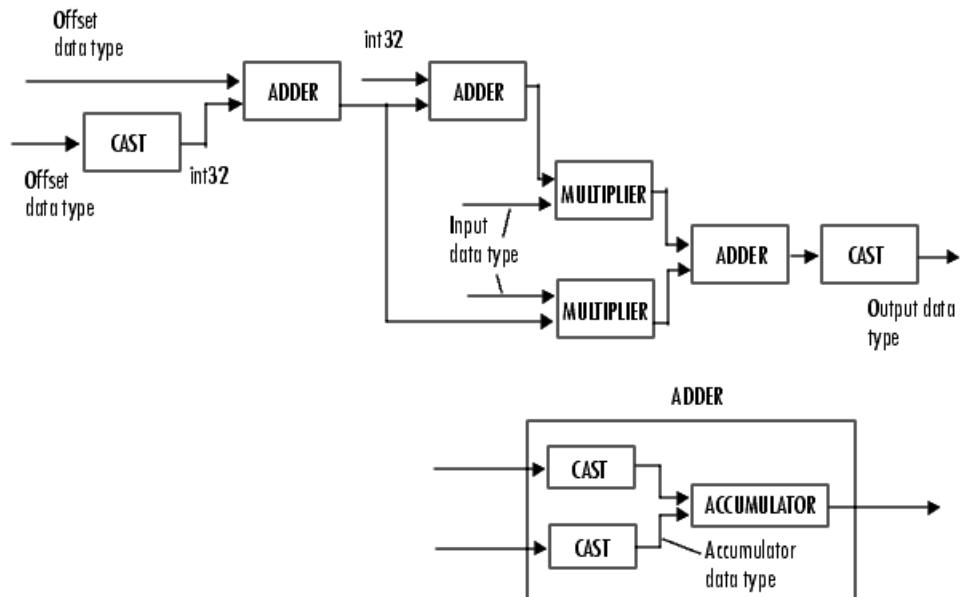

You can set the product output, accumulator, and output data types in the block mask as discussed below.

# Translate

## Dialog Box

The **Main** pane of the Translate block dialog appears as follows:

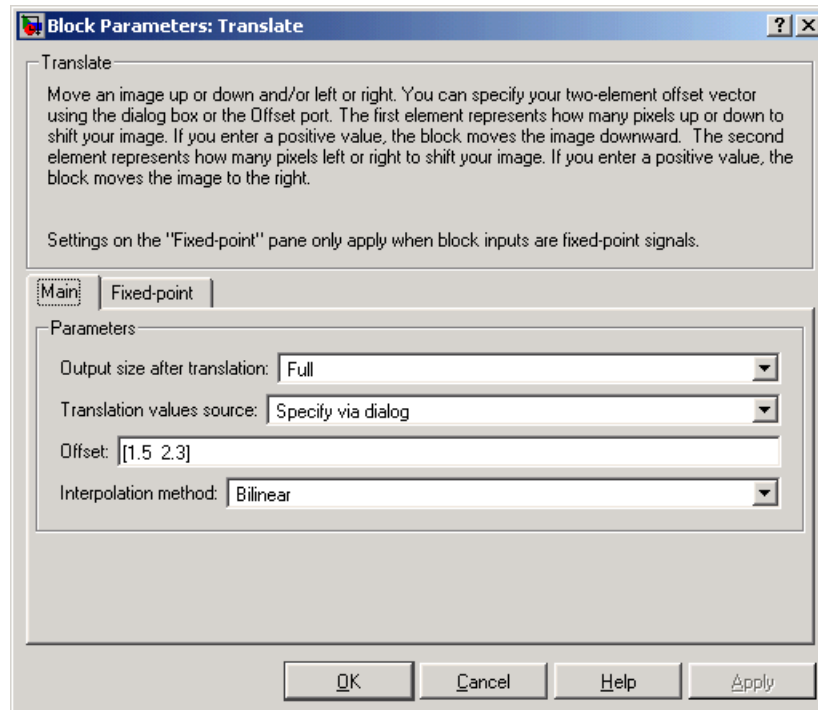

### Output size after translation

If you select **Full**, the block outputs a matrix that contains the translated image values and zeros for the values outside the image. If you select **Same as input image**, the block outputs a matrix that is the same size as the input image and contains a portion of the translated image and zeros for the values outside the image.

### Translation values source

Specify how you want to enter your translation parameters. If you select **Specify via dialog**, the **Offset** parameter appears on the dialog box. If you select **Input port**, port **O** appears on the

block. The block uses the input to this port at each time step as your translation values.

## **Offset**

Enter a vector of real, scalar values that represent the number of pixels by which you want to translate your image.

## **Interpolation method**

Specify which interpolation method the block uses to translate the image. If you select `Nearest neighbor`, the block uses the value of one nearby pixel for the new pixel value. If you select `Bilinear`, the new pixel value is the weighted average of the two nearest pixel values. If you select `Bicubic`, the new pixel value is the weighted average of the four nearest pixel values.

## **Maximum offset**

Enter a vector of real, scalar values that represent the maximum number of pixels by which you want to translate your image. This parameter must have the same data type as the input to the Offset port. This parameter is visible if, for the **Output size after translation** parameter, you select `Full` and, for the **Translation values source** parameter, you select `Input port`.

The **Fixed-point** pane of the Translate block dialog appears as follows:

# Translate

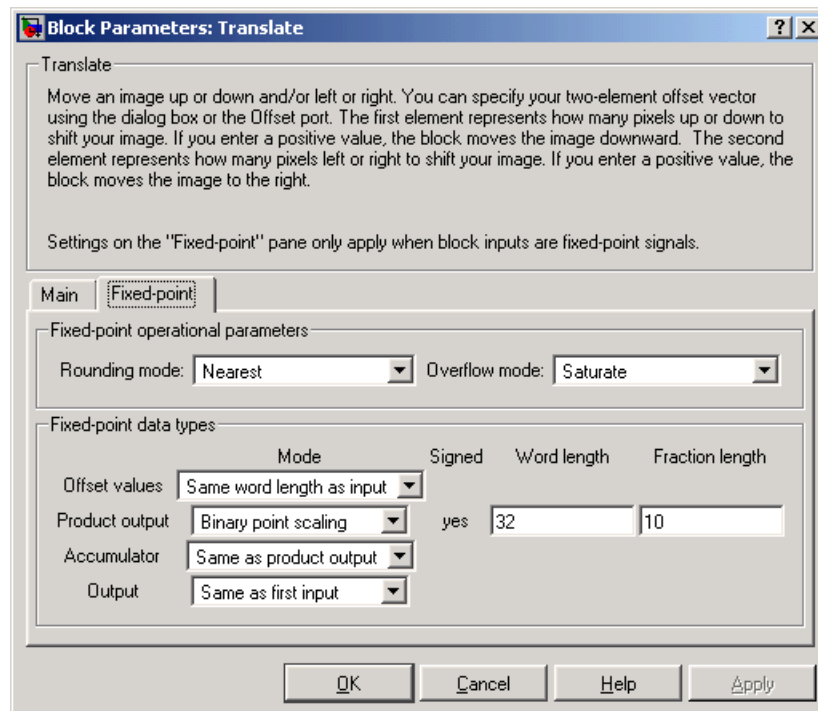

## **Rounding mode**

Select the rounding mode for fixed-point operations.

## **Overflow mode**

Select the overflow mode for fixed-point operations.

## **Offset values**

Choose how you will specify the word length and the fraction length of the offset values.

- When you select Same word length as input, the word length of the offset values will match that of the input to the block. In this mode, the fraction length of the offset values is automatically set to the binary-point only scaling that provides

you with the best precision possible given the value and word length of the offset values.

- When you select **Specify word length**, you can enter the word length of the offset values, in bits. The block automatically sets the fractional length to give you the best precision.
- When you select **Binary point scaling**, you can enter the word length and the fraction length of the offset values, in bits.
- When you select **Slope and bias scaling**, you can enter the word length, in bits, and the slope of the offset values. The bias of all signals in the Signal Processing Blockset is zero.

This parameter is visible if, for the **Translation values source** parameter, you select **Specify** via dialog.

## Product output



As depicted above, the output of the multiplier is placed into the product output data type and scaling. Use this parameter to specify how you would like to designate this product output word and fraction lengths.

- When you select **Same as first input**, these characteristics will match those of the first input to the block.
- When you select **Binary point scaling**, you can enter the word length and the fraction length of the product output, in bits.

# Translate

---

- When you select Slope and bias scaling, you can enter the word length, in bits, and the slope of the product output. The bias of all signals in the Signal Processing Blockset is zero.

## Accumulator

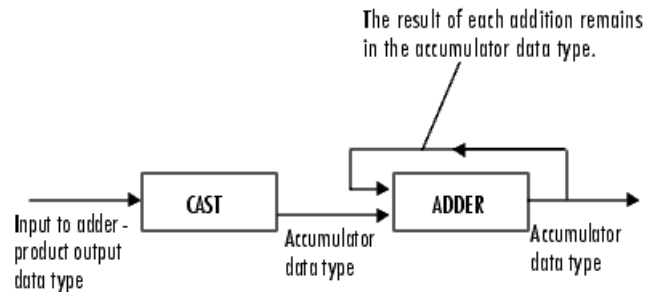

As depicted above, inputs to the accumulator are cast to the accumulator data type. The output of the adder remains in the accumulator data type as each element of the input is added to it. Use this parameter to specify how you would like to designate this accumulator word and fraction lengths.

- When you select Same as product output, these characteristics will match those of the product output.
- When you select Same as first input, these characteristics will match those of the first input to the block.
- When you select Binary point scaling, you can enter the word length and the fraction length of the accumulator, in bits.
- When you select Slope and bias scaling, you can enter the word length, in bits, and the slope of the accumulator. The bias of all signals in the Signal Processing Blockset is zero.

## Output

Choose how you will specify the word length and fraction length of the output of the block:



- When you select `Same` as `first` input, these characteristics will match those of the first input to the block.
- When you select `Binary point scaling`, you can enter the word length and the fraction length of the output, in bits.
- When you select `Slope and bias scaling`, you can enter the word length, in bits, and the slope of the output. The bias of all signals in the Video and Image Processing Blockset is zero.

## Reference

Wolberg, George. *Digital Image Warping*. Washington: IEEE Computer Society Press, 1990.

## See Also

Resize	Video and Image Processing Blockset
Rotate	Video and Image Processing Blockset
Shear	Video and Image Processing Blockset

# Variable Selector

---

**Purpose** Select subset of rows or columns from input

**Library** Utilities

**Description** The Variable Selector block is a Signal Processing Blockset block. For more information, see the Variable Selector block reference page in the Signal Processing Blockset documentation.

**Purpose** Import video signal from MATLAB workspace

**Library** Sources

## Description

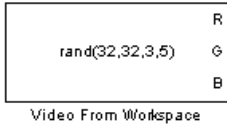

The Video From Workspace block imports a video signal from the MATLAB workspace. If the video signal is a M-by-N-by-T workspace array, the block outputs an intensity video signal, where M and N are the number of rows and columns in a single video frame, and T is the number of frames in the video signal. If the video signal is a M-by-N-by-C-by-T workspace array, the block outputs a color video signal, where M and N are the number of rows and columns in a single video frame, C is the number of color channels, and T is the number of frames in the video stream. In addition to the video signals described above, this block supports fi objects and variables that are in the structure format returned by the MATLAB `aviread` function.

---

**Note** If you generate code from a model that contains this block, Real-Time Workshop takes a long time to compile the code because it puts all of the video data into the `.c` file. Before you generate code, we recommend converting your video data to binary format and using the Read Binary File block. For more information about this block, see the Read Binary File block reference page.

---

Port	Output	Supported Data Types	Supports Complex Values?
I	Scalar, vector, or matrix of intensity values	<ul style="list-style-type: none"> <li>Double-precision floating point</li> <li>Single-precision floating point</li> <li>Fixed point</li> </ul>	No
R, G, B	Scalar, vector, or matrix that represents one plane of the RGB video stream. Outputs from	Same as I port	No

# Video From Workspace

Port	Output	Supported Data Types	Supports Complex Values?
	the R, G, or B ports have same dimensions.		

For Video and Image Processing Blockset blocks to display video data properly, double- and single-precision floating-point pixel values must be between 0 and 1. This block does not scale pixel values.

Use the **Signal** parameter to specify the MATLAB workspace variable from which to read. For example, to read an AVI file, use the following syntax:

```
mov = aviread('filename.avi')
```

The `aviread` function reads the AVI file into the MATLAB movie structure `mov`. Note that the MATLAB movie structure might be obsoleted in the future. For more information, see `aviread` in the MATLAB documentation.

If `filename.avi` has a colormap associated with it, the AVI file must satisfy the following conditions or the block produces an error:

- The colormap must be empty or have 256 values.
- The data must represent an intensity image.
- The data type of the image values must be `uint8`.

Use the **Sample time** parameter to set the sample period of the output signal.

When the block has output all of the available signal samples, it can start again at the beginning of the signal, repeat the final value, or generate zeros until the end of the simulation. The **Form output after final value by** parameter controls this behavior:

- When you specify Setting To Zero, the block generates zero-valued outputs for the duration of the simulation after generating the last frame of the signal.
- When you specify Holding Final Value, the block repeats the final frame for the duration of the simulation after generating the last frame of the signal.
- When you specify Cyclic Repetition, the block repeats the signal from the beginning after it reaches the last frame in the signal.

Use the **Output port labels** parameter to label your output ports. Use the spacer character, |, as the delimiter.

## Dialog Box

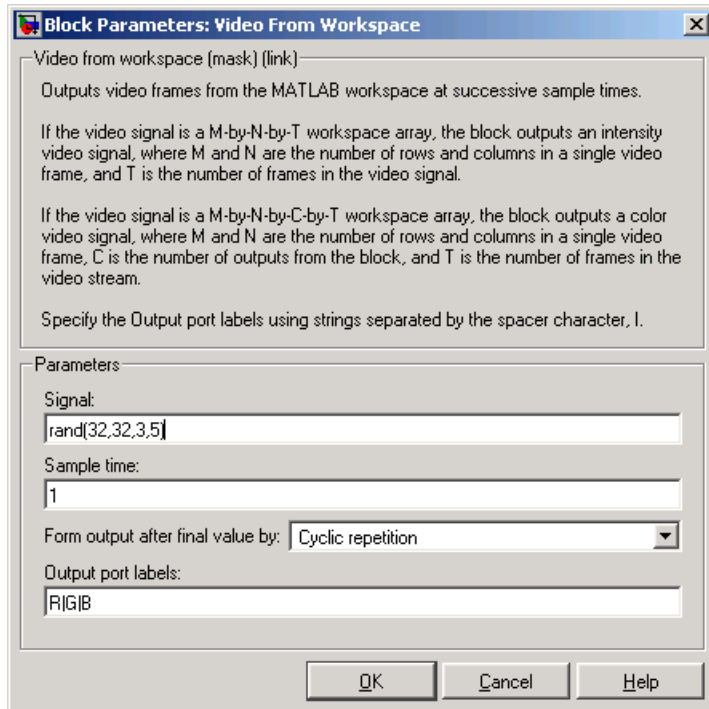

# Video From Workspace

---

## Signal

Specify the MATLAB workspace variable that contains the video signal, or use the `aviread` function to specify an AVI filename.

## Sample time

Enter the sample period of the output.

## Form output after final value by

Specify the output of the block after all of the specified signal samples have been generated. The block can output zeros for the duration of the simulation (Setting to zero), repeat the final value (Holding Final Value) or repeat the entire signal from the beginning (Cyclic Repetition).

## Output port labels

Enter the labels for your output ports using the spacer character, `|`, as the delimiter.

## See Also

Image From Workspace	Video and Image Processing Blockset
From Multimedia File	Video and Image Processing Blockset
To Video Display	Video and Image Processing Blockset
Video Viewer	Video and Image Processing Blockset

**Purpose** Export video signal to MATLAB workspace

**Library** Sinks

## Description

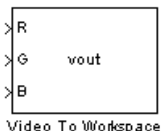

The Video To Workspace block exports a video signal to the MATLAB workspace. If the video signal is represented by intensity values, it appears in the workspace as a three-dimensional M-by-N-by-T array, where M and N are the number of rows and columns in a single video frame, and T is the number of frames in the video signal. If it is a color video signal, it appears in the workspace as a four-dimensional M-by-N-by-C-by-T array, where M and N are the number of rows and columns in a single video frame, C is the number of inputs to the block, and T is the number of frames in the video stream. This block does not support code generation.

Port	Input	Supported Data Types	Supports Complex Values?
I	Scalar, vector, or matrix of intensity values	<ul style="list-style-type: none"> <li>• Double-precision floating point</li> <li>• Single-precision floating point</li> <li>• Fixed point</li> </ul>	No
R, G, B	Scalar, vector, or matrix that represents one plane of the RGB video stream. Outputs from the R, G, or B ports have same dimensions.	Same as port I	No

Use the **Variable name** parameter to specify the MATLAB workspace variable to which to write the video signal.

Use the **Number of inputs** parameter to determine the number of inputs to the block. If the video signal is represented by intensity values, enter 1. If it is a color (R, G, B) video signal, enter 3.

## Video To Workspace

---

Use the **Limit video frames to last** parameter to determine the number of video frames,  $T$ , you want to export to the MATLAB workspace.

If you want to downsample your video signal, use the **Decimation** parameter to enter your decimation factor.

If your video signal is fixed point and you select the **Log fixed-point data as a fi object** check box, the block creates a `fi` object in the MATLAB workspace.

Use the **Input port labels** parameter to label your input ports. Use the spacer character, `|`, as the delimiter.



## Dialog Box

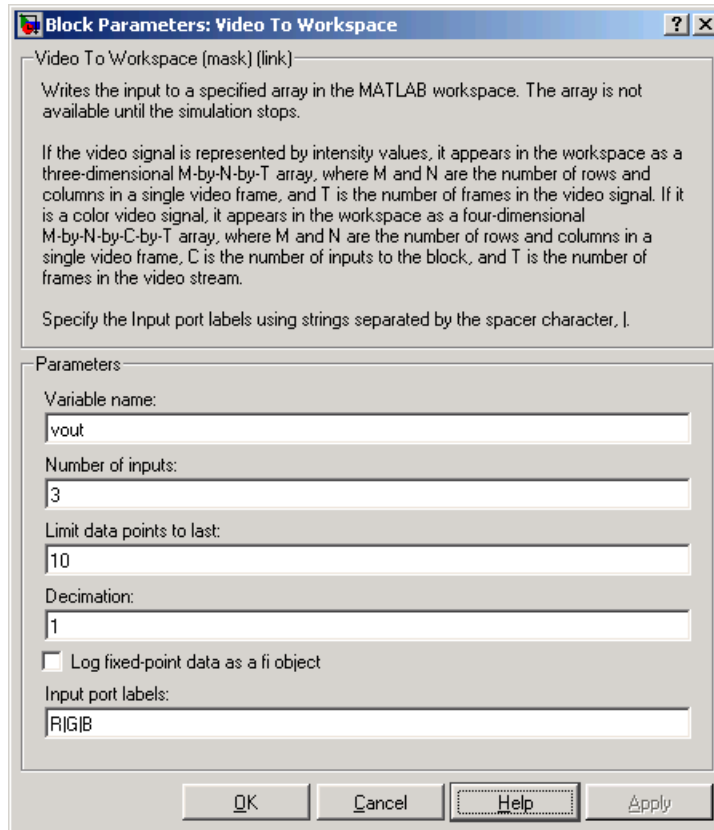

### Variable name

Specify the MATLAB workspace variable to which to write the video signal.

### Number of inputs

Enter the number of inputs to the block. If the video signal is black and white, enter 1. If it is a color (R, G, B) video signal, enter 3.

### Limit data points to last

Enter the number of video frames you want to export to the MATLAB workspace.

# Video To Workspace

---

## **Decimation**

Enter your decimation factor.

## **Log fixed-point data as a fi object**

If your video signal is fixed point and you select this check box, the block creates a fi object in the MATLAB workspace. For more information of fi objects, see the Fixed-Point Toolbox documentation.

## **Input port labels**

Enter the labels for your input ports using the spacer character, |, as the delimiter.

## **See Also**

Signal To Workspace

To Multimedia File

To Video Display

Video Viewer

Signal Processing Blockset

Video and Image Processing Blockset

Video and Image Processing Blockset

Video and Image Processing Blockset

**Purpose** Display binary, intensity, or RGB images or video streams

**Library** Sinks

**Description** The Video Viewer block enables you to view a binary, intensity, or RGB image or a video stream. This block does not support code generation.



Port	Output	Supported Data Types	Supports Complex Values?
I	Scalar, vector, or matrix of intensity values	<ul style="list-style-type: none"> <li>• Double-precision floating point</li> <li>• Single-precision floating point</li> <li>• Boolean</li> <li>• 8-, 16-, and 32-bit signed integers</li> <li>• 8-, 16-, and 32-bit unsigned integers</li> </ul>	No
R, G, B	Scalar, vector, or matrix that represents one plane of the RGB video stream. Inputs to the R, G, or B ports must have the same dimensions and data type.	Same as port I	No

Use the **Input image type** parameter to specify the type of image or video stream you want to view. If you select RGB, the R, G, and B ports appear on the block. Use this option for RGB images and video. If you select Intensity, the I port appears on the block. Use this option for binary and intensity images and video.

If, for the **Input image type** parameter, you select Intensity, you can set additional block parameters. If you select the **Use colormap** check box, you can use the **Colormap** parameter to specify a colormap or a call to a colormap-generating function. MATLAB provides a number of functions for generating predefined colormaps, such as hot, cool, bone, and autumn. Each of these functions accepts the colormap size as an argument, and can be used in this parameter. For example, if you enter gray(128), the image is displayed in 128 shades of gray. The color in the first row of the colormap matrix represents the minimum input value and the color in the last row represents the maximum input value. Values between the minimum and maximum are quantized and mapped to the intermediate rows of the colormap matrix. For more information, see the MATLAB colormap function documentation.

If you select the **Specify range of values** check box, you can use the **Minimum input value** and **Maximum input value** parameters to define the range of your input. If you do not specify a range, the block assumes that Boolean, double-precision floating-point, and single-precision floating-point signals range from 0 to 1, and any other signals range between the minimum and maximum values supported by their data type.

## Dialog Box

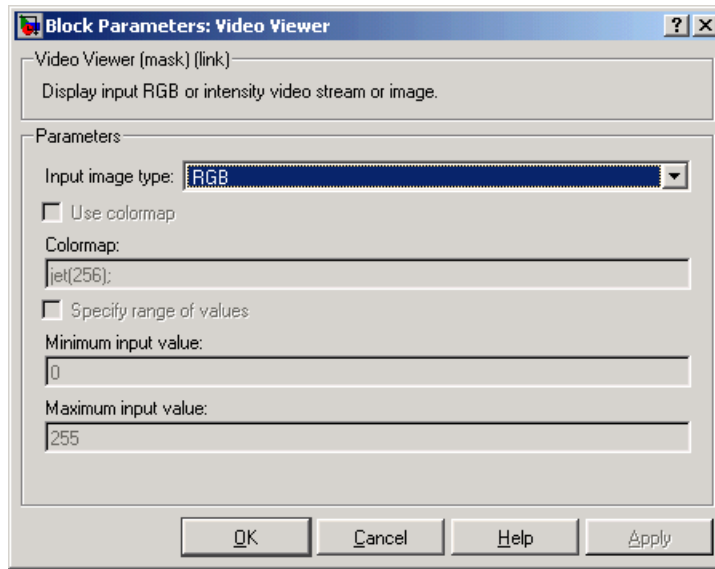

### Input image type

Specify the type of image or video stream you want to view. Your choices are RGB or Intensity.

### Use colormap

Select this check box if you want to specify a colormap. This parameter is available if, for the **Input image type** parameter, you select Intensity.

### Colormap

Specify the colormap to apply to the intensity image or video by entering a 3-column matrix defining the colormap or a call to a colormap-generating function such as hot, cool, gray, or spring. This parameter is available if you select the **Use colormap** check box.

# Video Viewer

---

## **Specify range of values**

Select this check box if you want to define the range for the input. This parameter is available if, for the **Input image type** parameter, you select Intensity.

## **Minimum input value**

Use this parameter to define the range of the input; enter the smallest input value. This parameter is available if you select the **Specify range of values** check box.

## **Maximum input value**

Use this parameter to define the range of the input; enter the largest input value. This parameter is available if you select the **Specify range of values** check box.

## **See Also**

From Multimedia File	Video and Image Processing Blockset
To Multimedia File	Video and Image Processing Blockset
To Video Display	Video and Image Processing Blockset
Video To Workspace	Video and Image Processing Blockset

**Purpose** Write video frames to uncompressed AVI file

**Library** Sinks

**Description**



The Write AVI file writes video frames to an uncompressed AVI file from a Simulink model. If the data type of the input pixel values is anything other than 8-bit unsigned integers, the block scales the values. Then, it writes values between the minimum and maximum values supported by the 8-bit unsigned integer data type to the AVI file. This block does not support audio samples or code generation.

Port	Input	Supported Data Types	Supports Complex Values?
I	Matrix of intensity values	<ul style="list-style-type: none"> <li>• Double-precision floating point</li> <li>• Single-precision floating point</li> <li>• Boolean</li> <li>• 8-, 16- 32-bit signed integers</li> <li>• 8-, 16- 32-bit unsigned integers</li> </ul>	No
R, G, B	Matrix that represents one plane of the RGB video stream. Inputs to the R, G, or B ports must have the same dimensions.	Same as port I	No

Use the **File name** parameter to specify the name of the AVI file to which to write. The block creates the AVI file in your current directory. To specify a different directory, use the **Browse** button; then enter the filename.

Use the **Input image type** parameter to specify the type of video input into the block. If the input contains RGB video frames, select RGB. If the input contains intensity video frames, select Intensity.

# Write AVI File

---

## Dialog Box

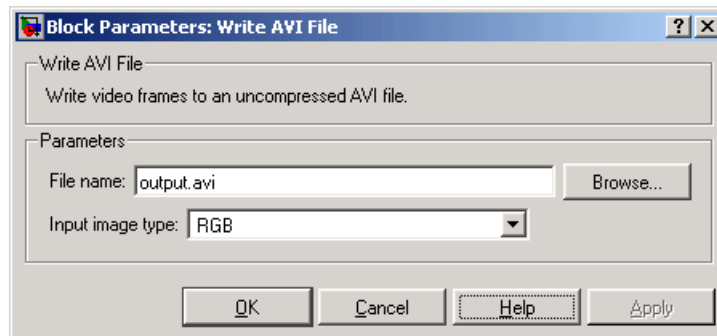

### File name

Specify the name of the AVI file to which to write.

### Input image types

Specify the type of video input into the block. If the input contains RGB video frames, select RGB. If the input contains intensity video frames, select Intensity.

## See Also

Read AVI File	Video and Image Processing Blockset
To Multimedia File	Video and Image Processing Blockset
To Video Display	Video and Image Processing Blockset
Video To Workspace	Video and Image Processing Blockset
Video Viewer	Video and Image Processing Blockset



**Purpose** Write binary video data to files

**Library** Sinks

**Description** The Write Binary File block takes video data from a Simulink model and exports it to a binary file.

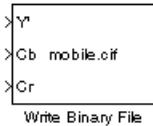

Port	Input	Supported Data Types	Supports Complex Values?
Y, Cb, Cr	Matrix that represents the luma (Y) and chroma (Cb and Cr) components of a video stream	<ul style="list-style-type: none"> <li>8-, 16- 32-bit unsigned integers</li> </ul>	No

Use the **File name** parameter to specify the name of the binary file. If the location of this file is on your MATLAB path, enter the filename. If the location of this file is not on your MATLAB path, use the **Browse** button to specify the full path to the file as well as the filename.

Use the **Video format** parameter to specify the format of the binary video data. Your choices are Four character codes or Custom. See “Four Character Code Video Formats” on page 9-408 or “Custom Video Formats” on page 9-408 for more details.

Use the **Line ordering** parameter to determine how the block fills the binary file. If you select Top line first, the block first fills the binary file with the first row of the video frame. It fills the file with the other rows in increasing order. If you select Bottom line first, the block first fills the binary file with the last row of the video frame. It fills the file with the other rows in decreasing order.

# Write Binary File

---

## Four Character Code Video Formats

Four Character Codes (FOURCC) are used to identify video formats. For more information about these codes, see <http://www.fourcc.org>.

Use the **Four character code** parameter to identify the video format.

## Custom Video Formats

You can use the Write Binary File block to create a binary file that contains video data in a custom format.

Use the **Bit stream format** parameter to specify whether you want your data in planar or packed format.

Use the **Number of input components** parameter to specify the number of components in the video stream. This number corresponds to the number of block input ports.

Use the **Component** parameters to specify the component names.

Use the **Component order in binary file** parameter to specify how to arrange the components in the binary file.

Select the **Interlaced video** check box if the video stream represents interlaced video data.

## Dialog Box

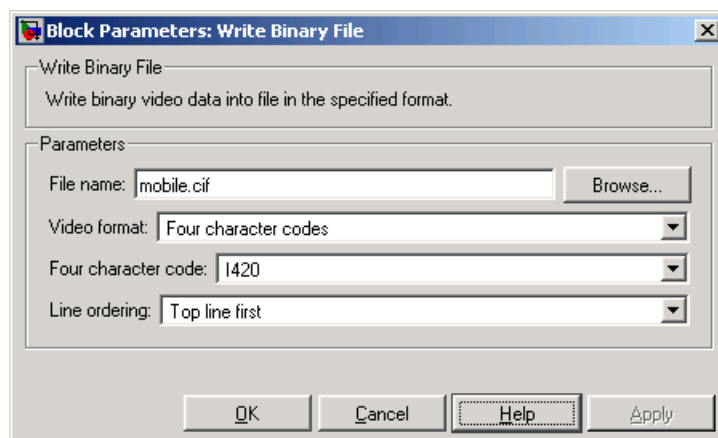

## File name

Specify the name of the binary file.

## Video format

Specify the format of the binary video data. Your choices are Four character codes or Custom.

## Four character code

From the list, select the binary file format.

## Line ordering

Specify how the block fills the binary file. If you select **Top line first**, the block first fills the binary file with the first row of the video frame. If you select **Bottom line first**, the block first fills the binary file with the last row of the video frame.

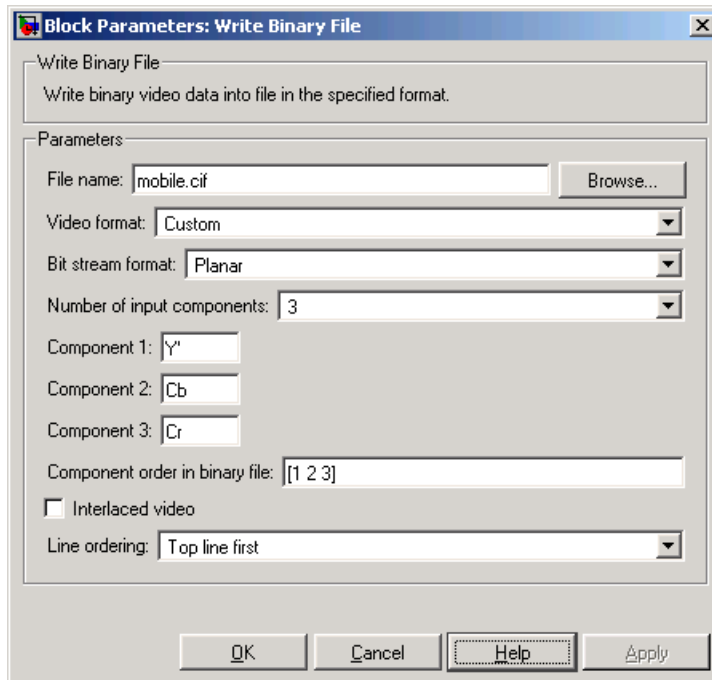

# Write Binary File

---

## **Bit stream format**

Specify whether you want your data in planar or packed format.

## **Number of input components**

Specify the number of components in the video stream. This number corresponds to the number of block input ports

## **Component**

Specify the component names.

## **Component order in binary file**

Specify how to arrange the components in the binary file.

## **Interlaced video**

Select this check box if the video stream represents interlaced video data.

## **See Also**

To Multimedia File    Video and Image Processing Blockset  
Write AVI File        Video and Image Processing Blockset

- 2-D Autocorrelation block 9-2
- 2-D Convolution block 9-8
- 2-D Correlation block 9-19
- 2-D DCT block 9-30
- 2-D FFT block 9-39
- 2-D FIR Filter block 9-53
- 2-D Histogram block 9-62
- 2-D IDCT block 9-72
- 2-D IFFT block 9-81
- 2-D Maximum block 9-94
- 2-D Mean block 9-104
- 2-D Median block 9-112
- 2-D Minimum block 9-118
- 2-D Pad 9-128
- 2-D Standard Deviation block 9-138
- 2-D Variance block 9-145

## A

- Accelerator mode 1-18
- adding periodic noise to a signal 6-23
- Adobe Acrobat Reader 1-8
- algorithms
  - bicubic interpolation 4-4
  - bilinear interpolation 4-3
  - nearest neighbor interpolation 4-2
- angles
  - rotation 4-6
- arrays
  - interpretation of 1-11
- artifacts
  - in an image 6-23
- Autothreshold block 9-155
  - to perform thresholding 3-7
- AVI files
  - exporting 2-5
  - importing 2-2
  - viewing 2-2

## B

- background
  - estimation 5-11
  - pixels 6-2
  - user\xd5 s expected 1-8
- bicubic interpolation 4-4
- bilinear interpolation 4-3
- binary
  - conversion from intensity 3-2
  - images 1-12
- Blob Analysis block 9-159
- Block Processing block 9-172
- blurring images 6-10
- Boolean matrices 1-12
- Bottom-hat block 9-181
- boundaries
  - of objects 6-2
- boundary artifacts 6-23
- brightening images 5-11

## C

- capabilities of
  - Video and Image Processing Blockset 1-2
- CD installation 1-3
- changing
  - image size 4-14
- chapter descriptions 1-9
- chroma components
  - of images 3-19
- chroma resampling 3-19
- Chroma Resampling block 9-184
- chrominance resampling 3-19
- Closing block 9-189
- codecs
  - supported by Microsoft Windows Media Player 2-9
- color
  - definition of 1-12
- color space conversion 3-14

- Color Space Conversion block 9-192
- colormaps 1-12
- column-major format 1-15
- compensation
  - for motion 7-8
- Compositing block 9-196
- compression
  - of images 7-10
  - of video 7-8
- concepts
  - description of 1-11
- Configuration dialog box 1-16
- continuous rotation 4-6
- contrast
  - increasing 2-12
- controlling video duration 1-17
- conventions
  - column-major format 1-15
- conversion
  - color space 3-14
  - intensity to binary 3-2
  - R'G'B' to intensity 3-14
- correction
  - of uneven lighting 5-11
- correlation
  - used in object tracking 7-2
- counting objects 5-3
- cropping
  - images 4-21

**D**

- data types 1-12
- definition of
  - intensity and color 1-12
- demos
  - in the Help browser 1-5
  - on MATLAB Central 1-6
  - on the Web 1-6
  - Periodic noise reduction 6-23

- Video compression 7-8
- Video stabilization 7-8
- dependencies
  - on Windows dynamic libraries 1-19
- detection of
  - edges 6-2
- dilation 5-2
- Dilation block 9-205
- DirectX 2-9
- dlls
  - dependencies on 1-19
- documentation
  - on the Web 1-7
  - on your system 1-7
  - PDF 1-8
  - printing 1-8
  - viewing 1-7
- downsampling
  - chroma components 3-19
- Draw Shapes block 9-219
- dynamic range 1-12

## **E**

- edge
  - pixels 6-2
  - thinning 6-2
- edge detection 6-2
- Edge Detection block 9-228
- electrical interference 6-23
- erosion 5-2
- Erosion block 9-237
- estimation
  - of image background 5-11
- executables
  - running 1-19
- exporting
  - AVI files 2-5
  - multimedia files 2-12

**F**

- filtering
  - median 6-17
  - operations 5-2
- Find Local Maxima 9-241
- finding
  - edges of objects 6-2
  - histograms of images 6-30
- form of objects 5-2
- Frame Rate Display block 9-246
- frequency distribution
  - of elements in an image 6-30
- From Multimedia File block 9-248
- fspecial function 6-10

**G**

- gamma correction 3-14
- Gamma Correction block 9-249
- geometric transformation 4-1
- gradient components
  - of images 6-2

**H**

- Help browser
  - demos 1-5
  - documentation 1-7
- Histogram Equalization block 9-254
- histograms
  - of images 6-30
- Hough Lines block 9-257
- Hough Peaks block 9-245
- Hough Transform block 9-266

**I**

- Image Complement block 9-274
- image compression 7-10
- image credits 1-21

- image data
  - storage of 1-15
- Image Data Type Conversion block 9-276
- Image From File block 9-279
- Image From Workspace block 9-285
- image rotation 4-6
- image types 1-11
- images
  - binary 1-12
  - boundary artifacts 6-23
  - brightening 5-11
  - correcting for uneven lighting 5-11
  - counting objects in 5-3
  - cropping 4-21
  - filtering of 5-2
  - finding edges in 6-2
  - finding histograms of 6-30
  - gradient components 6-2
  - intensity 1-12
  - intensity to binary conversion 3-2
  - labeling objects in 5-3
  - lightening 5-11
  - noisy 6-17
  - periodic noise removal 6-23
  - removing salt and pepper noise 6-17
  - resizing of 4-14
  - RGB 1-12
  - rotation of 4-6
  - segmentation of 5-2
  - sharpening and blurring 6-10
  - true-color 1-12
  - types of 1-11
- importing
  - AVI files 2-2
  - multimedia files 2-9
- improvement
  - of performance 1-18
- increasing video contrast 2-12
- Insert Text block 9-290
- installation

- CD 1-3
- Video and Image Processing Blockset 1-3
- Web download 1-3
- intensity
  - conversion from R'G'B' 3-14
  - conversion to binary 3-2
  - definition of 1-12
  - images 1-12
- interference
  - electrical 6-23
- interpolation
  - bicubic 4-4
  - bilinear 4-3
  - examples 4-2
  - nearest neighbor 4-2
  - overview 4-2
- interpretation of
  - matrices 1-11
- irregular illumination 5-11

## **K**

- key blockset concepts 1-11
- knowledge
  - user\%d5 s expected 1-8

## **L**

- Label block 9-298
- labeling objects 5-3
- lightening images 5-11
- location of
  - object edges 6-2
  - objects in an image 7-2
- luma components
  - applying highpass filter 6-10
  - applying lowpass filter 6-10
  - of images 3-19
- luminance 3-19

## **M**

- matching
  - patterns in an image 7-2
- MATLAB Central
  - demos 1-6
- matrices
  - interpretation of 1-11
- measurement operations 5-2
- Median Filter block 9-315
- median filtering 6-17
- methods
  - interpolation 4-2
  - sum of absolute differences (SAD) 7-8
  - thresholding 5-11
- Microsoft Windows Media Player 2-9
- modes
  - Normal and Accelerator 1-18
- morphology 5-1
  - opening 5-3
  - overview 5-2
  - STREL object 5-3
- motion compensation 7-8
- motion detection 7-8
- MPlay block 9-302
- multimedia files
  - exporting 2-12
  - importing 2-9
  - viewing 2-9

## **N**

- nearest neighbor interpolation 4-2
- noise
  - adding to a signal 6-23
- noise removal
  - periodic 6-23
  - salt and pepper 6-17
- nonuniform illumination
  - correcting for 5-11
- Normal mode 1-18



**O**

- object boundaries 6-2
- object extraction 5-2
- object tracking
  - using correlation 7-2
- objects
  - delineating 5-11
  - location of 7-2
- opening 5-3
- Opening block 9-324
- operations
  - morphological 5-1
  - thresholding 3-2
- organization of the chapters 1-9
- overview of
  - documentation 1-9
  - interpolation 4-2
  - morphology 5-2
  - Video and Image Processing Blockset 1-2

**P**

- padding 6-23
- pattern matching 7-2
- performance
  - improving 1-18
- periodic noise
  - removal 6-23
- printing
  - PDF documentation 1-8
- product demos 1-5
- products
  - related 1-4
  - required 1-4

**R**

- R'B'G'
  - conversion to intensity 3-14
- Read AVI File block 9-327

- reception
  - of an RGB image 3-19
- reconstruction
  - of images 7-10
- reduction
  - of image size 4-14
- region of interest
  - cropping to 4-21
  - visualizing 7-2
- related products 1-4
- relational operators
  - to perform thresholding 3-2
- removal of
  - periodic noise 6-23
  - salt and pepper noise 6-17
- required products 1-4
- resampling
  - chroma 3-19
- Resize block 9-335
- resizing
  - images 4-14
- RGB images 1-12
- Rotate block 9-344
- rotation
  - continual 4-6
  - of an image 4-6

**S**

- SAD block 9-355
- salt and pepper noise removal 6-17
- sample time 1-16
- scaling 1-12
  - data types 6-2
- segmentation operations 5-2
- setting
  - configuration parameters 1-16
  - simulation time 1-17
- shape of objects 5-2
- sharpening images 6-10

- Shear block 9-365
- shrinking
  - image size 4-14
- simulation time 1-17
- Simulink Solver 1-16
- Sobel kernel 6-2
- stabilization
  - of video 7-8
- storage of image data 1-15
- STREL object 5-3
- sum of absolute differences (SAD) method 7-8
- summary of morphology 5-2

## T

- techniques
  - motion compensation 7-8
  - sum of absolute differences (SAD) 7-8
  - thresholding 5-11
- thresholding operation 3-2
  - with uneven lighting 3-7
- thresholding techniques 5-11
- To Video Display block 9-376
- Top-hat block 9-380
- tracking
  - of an object 7-2
- transformation
  - geometric 4-1
- Translate block 9-383
- transmission
  - of an RGB image 3-19
- trimming
  - images 4-21
- true size 2-2
- true-color images 1-12
- tutorials 1-9
- types of images 1-11

## U

- uneven lighting
  - correcting for 5-11

## V

- Variable Selector 9-392
- vectors
  - motion 7-8
- video
  - adjusting display size 2-2
  - duration 1-17
  - exporting from AVI file 2-5
  - exporting from multimedia file 2-12
  - importing from AVI file 2-2
  - importing from multimedia file 2-9
  - increasing the contrast of 2-12
  - interpretation of 1-12
  - speed of 2-9
  - stabilization 7-8
- video compression and stabilization 7-8
- Video From Workspace block 9-393
- Video To Workspace block 9-397
- Video Viewer block 9-401
- viewing
  - AVI files 2-2
  - compressed images 7-17
  - demos 1-5
  - documentation 1-7
  - multimedia files 2-9
- vip\_rt.dll 1-19

## W

- Web
  - demos 1-6
  - documentation 1-7
  - download 1-3
- Windows dynamic libraries
  - dependencies on 1-19

Windows platforms 2-9  
Write AVI File block 9-405

Write Binary File 9-407